



ONE AAC

PANEL

AAC FIRE & ACOUSTIC SOLUTIONS

50mm & 75mm AAC EXTERNAL WALL SYSTEM

DESIGN & INSTALLATION MANUAL

September 2019 Edition



Preface

The ONE AAC PANEL External Wall System Design & Installation Manual has been developed to provide design, installation and technical information to 'end users' ranging from the owner builder, licensed builders, building consultants, designers, architects and engineers.

Although the details provided in this Design & Installation Manual have been developed by ONE AAC and are intended to represent good building practice, the registered professionals involved in the project (such as the licensed builder, architectural designer and engineering consultant) must ensure that the information provided in this Design & Installation Manual is appropriate and suitable for the project.

Contents

Introduction To ONE AAC 3-6

- ❖ What is AAC
- ❖ ONE AAC PANEL - Features and Benefits
- ❖ Material Properties

BCA Compliance 7

- ❖ Compliance with the Building Code of Australia)

System Overview & Performance 8-12

- ❖ Structure – (Mass, Wind Zone, Impact)
- ❖ Durability
- ❖ External Moisture – Damp and Weather Proofing
- ❖ Fire Resistance / Bush Fire Zone Compliance
- ❖ Energy Efficiency (R-Values)
- ❖ Acoustic Performance

Design & Construction 13-14

- ❖ Design Principals
- ❖ Frame Design
- ❖ Design Detail Considerations

System Components 15-17

- ❖ Cavity Battens and Fasteners
- ❖ Panels and Panel Fasteners
- ❖ Adhesive, Corrosion Protection Paint
- ❖ Flashing, Sarking, Adhesive and Sealants

Installation of ONE AAC Panels 18-20

- ❖ System Installation Sequence
- ❖ Installation Summary
- ❖ Services – Plumbing and Electrical
- ❖ Tools & Equipment

Approved Coating System 21-22

- ❖ Components
- ❖ Specification

Delivery Storage & Handling 23

- ❖ Delivery
- ❖ Storage and Handling

Occupational Health and Safety 23

Warranty & Guarantee 24

Drawings & Details Pages

■ Vermin Control Cavity Closer	25,31,32,42,43&45
■ Batten Specification	25 & 26
■ Batten and Panel Layout	27
■ Batten & Panel Screw Spacing	28
■ General Arrangement	29
❖ Timber or Metal Wall Framing	
■ Eave Options	30
■ Base Detail	31&32
❖ Rebated Step-Down	
❖ Brick Course Step-Down	
❖ Overhanging-Rebate Foundation	
■ Inter-Floor Detail	32&34
❖ Timber or Steel Frame	
❖ Concrete Frame (Slab to Slab)	
➤ Exposed & Concealed Edge Beam	
■ Internal & External Corner Junction	35
■ Cladding Change Junctions	36&37
■ Bracket / Wall Junction	38
■ Window and Door Details	39
■ Threshold Options	40
■ Soffit/Wall/Roof Junctions	41-44
■ Parapet / Roof Detail	45&46
■ Column / Post Details	47
■ Garage Door / Opening Details	48&49
■ Meter Box Detail	50
■ Penetration Details	50
■ Control Joint Detail	51
■ Boundary Wall Details	52

CodeMark Certificate Of Conformity 53

Gallery 60

Introduction

ONE AAC Panel was previously referred to as Loxo Cladding Systems (NSW) Pty Ltd, but is now trading as ONE AAC Panel.

ONE AAC Panel is known as a market leader in Aerated Autoclaved Concrete (AAC) Panel Solutions for residential and commercial construction.

ONE AAC combines 25 years of construction experience, product and systems development knowledge and material distribution expertise, to ensure its customers receive the best construction solutions for their projects, at the best possible price, with the fastest possible turnaround.

ONE AAC provides the construction industry with specialised **Fire** and **Acoustic** Solutions for **wall** and **floor** systems, in both **commercial** and **residential** applications.

Solutions include, but are not limited to:

- Internal Wall Systems (Indoor Walls / Intertenancy Walls / Party Walls / Corridor Walls. / Shaft Walls) – in both Low Rise and High Rise Residential markets
- External Wall Systems – Rendered Low Rise and High Rise Façades
- Boundary Walls - Single and Torrens Title Dual Wall Options
- Floor and Ceiling Systems
- Fence Systems - Boundary and Estate Fencing Solutions

Contact us on **1300 010 222** or www.oneaac.com.au for more information on how these solutions can work for you.

Solutions Can Be Resolved in 50mm or 75mm Thick ONE AAC PANEL - The Choice is Yours.

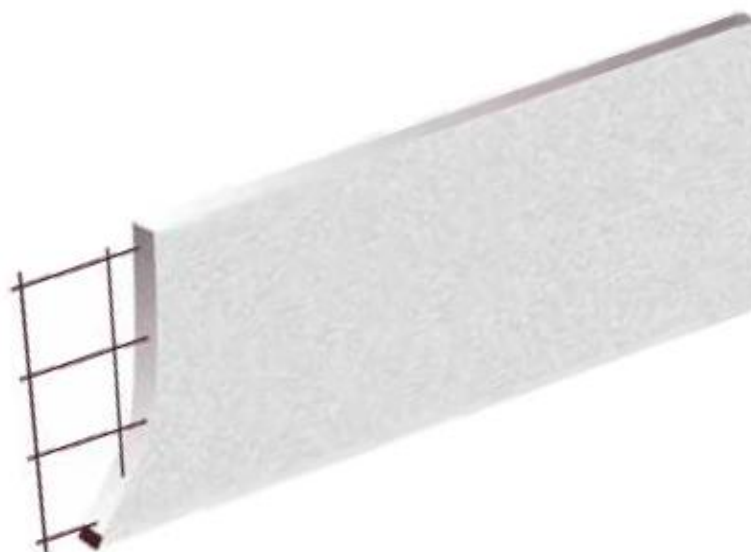

STEEL REINFORCED - 50MM AND 75MM ONE AAC PANEL

What Is AAC? (Lightweight Concrete)

Autoclaved Aerated Concrete (AAC) is manufactured from cement, sand (silica), lime and water, it is aerated by adding an expanding agent to the mix (small amounts of aluminium paste). The mix is poured into a mould (a very large cake tin), to approximately 2/3 of the height of the mould, almost instantly the expanding agent reacts with the other elements, and the mix begins to rise in the mould. (A chemical reaction expands the mixture to form small, finely-dispersed air bubbles).

The moulds are pre-cured in a heated room for several hours. Then the semi-solid material (still in a green state) is transported to the cutting machine. The soft but semi-solid block is sliced into the required panel size using steel wires. Once sliced, the block is steam pressure cured in autoclaves for up to 12 hours. The expanding chemical reaction combined with the Autoclave process is what gives AAC it's unique properties. AAC has excellent thermal insulation and acoustic absorption properties, it has superior fire resistance qualities and is also termite resistant.

Its properties and specification satisfy all relevant building codes. Working with AAC is easy and efficient. AAC is both versatile and economical. AAC meets the diverse demands better than any other material due to the numerous advantages of its physical and mechanical properties.

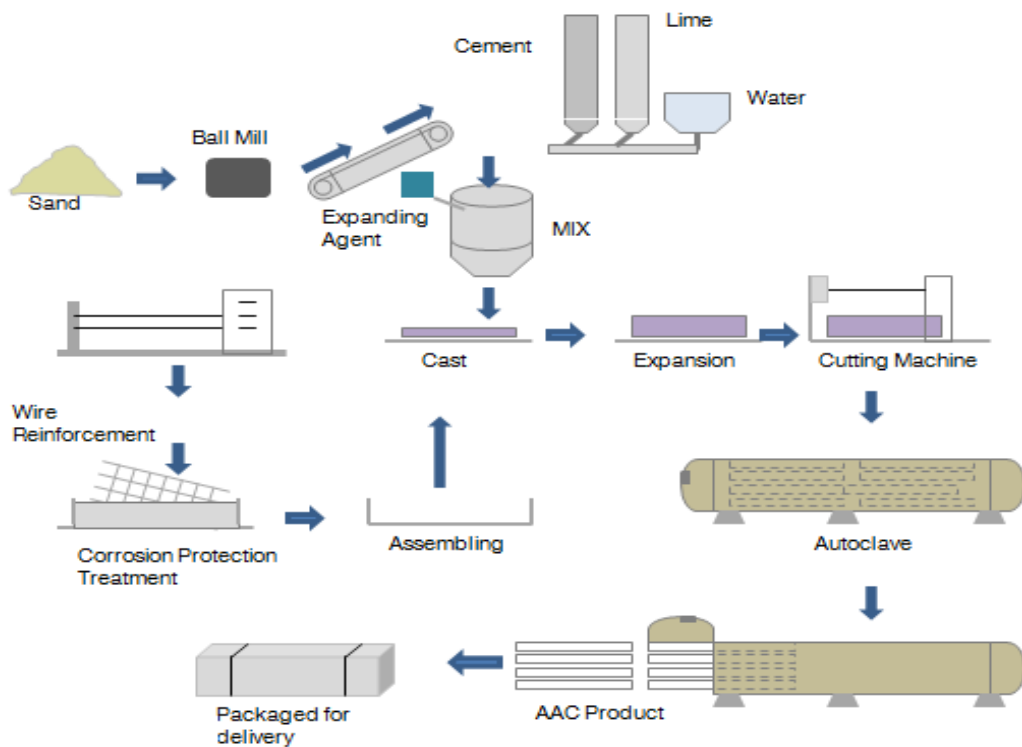

THE ONE AAC PANEL MANUFACTURING PROCESS

ONE AAC PANEL – Why You Should Use It

The ONE AAC Panel System is an exterior wall cladding system that provides a lightweight, high-quality, and highly durable cladding solution perfectly suited to both residential and commercial applications.

The ONE AAC Panel System comprises, steel reinforced panels manufactured from autoclaved aerated concrete (AAC). AAC lightweight reinforced panels are a trusted building material; they have been used in the building industry for several decades in Europe and for the last few decades in Australia and New Zealand.

With exterior coating solutions provided by ONE AAC approved Coating Partners, the ONE AAC Panel system is one of the most attractive and robust cladding systems on the market today.

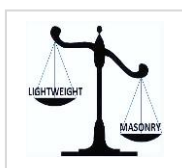

Solid and as durable as masonry yet lightweight

ONE AAC Panels pass the 'knock test' by consumers because they are a masonry product. Further to that, ONE AAC panels are steel reinforced with corrosion protected steel adding to greater strength and security. The average mass of the 50/75mm thick panels are less than 40/62kg respectively, making it a convenient lightweight product, easily installed by a two-man installation process.



Living in a comfortable environment

The ONE AAC Panel System is able to achieve very good R-Values as a result of the combination of Thermal Mass and Thermal Resistance. The R-Value can be related to the comfort levels within a dwelling. The greater the R-Value, the more comfortable the temperature will be within that dwelling. The ONE AAC Panel System easily achieves the Thermal requirements as set out in the BCA.



High fire resistance adds to the security.

AAC Material is known for its high fire resistance. It will not combust in the event of fire and will not omit toxic gases. The ONE AAC Panel External Wall Systems provide a Load Bearing FRL up to 120/120/120. The ONE AAC Panel Wall System also complies with all six (Bush Fire Attack Level Categories (BAL) for external wall cladding.



Sound acoustic qualities

The ONE AAC Panel System provides acoustic performance levels equivalent to other masonry products that are twice as thick. Although the acoustic performance of residential external walls is not a requirement of the BCA, it is reassuring to know that acoustic performance is achieved when you use the ONE AAC Panel System.



Design flexibility and aesthetic appeal

ONE AAC provides building designers the flexibility of utilising a masonry product in areas previously restricted to non-masonry cladding products. ONE AAC allows designers and consumers the ability to create that inspirational and contemporary look, with a large range of finishes and colours provided by our coating partners. With ONE AAC the only limitation to your design is your imagination.



Reduce your Building Cost

The ONE AAC cladding system is simple and flexible insofar as it only requires semi-skilled trades and allows you the choice to self-install using existing lower costs trades or have it supplied and installed by approved installers. Either way this saves you time and money compared to traditional rendered masonry.



Speed of Construction

50mm ONE AAC panels are delivered flat packed for ease of workability, less labour and with considerable site cost savings. The speed of construction reaches key stages quickly. ONE AAC means a safe and clean worksite with less clean-up at the completion of the project. Two men can easily install an average of 50m² of panel per day.

Material Properties

Property	50MM PANELS		75MM PANELS	
	Value	Units	Value	Units
Ambient ¹ Density, ρ_{amb}	520	kg/m ³	520	kg/m ³
Dry ² Density, ρ_{dry}	500	kg/m ³	500	kg/m ³
Working ³ Density, ρ_{design}	610	kg/m ³	622	kg/m ³
Permanent Action, G	0.3	kN/m ²	0.5	kN/m ²
Characteristic Unconfined Compressive Strength, f_{uc}	1.1	MPa	1.1	MPa
Modulus of Rupture, f_{ut}	0.73	MPa	0.73	MPa
Design Ultimate Limit State Bending Capacity, ϕM	0.12	kNm	0.25	kNm
Design Serviceability Limit State Deflection Limit, δ_{max}	SPAN/240		SPAN/240	
Coefficient of contraction	0.4	mm/m	0.4	mm/m
Coefficient of thermal expansion	10	x10 ⁻⁶ /°C	10	x10 ⁻⁶ /°C

Notes:

1. Ambient density is that achieved by the product when it has reached equilibrium at 23°C, 50% RH. The moisture content by mass in this state is typically between 2% and 5%.
2. Dry density is the manufacturer's reported density, the typical frame of reference for grading AAC material. It is achieved by oven drying specimens so that the moisture content is 0%.
3. Working density is to be used for calculation of effects due to permanent actions.
4. Moment capacity quoted is for 600mm wide panels.

Quality from start to finish

It is highly recommended that ONE AAC panels are erected by approved Installers and coated by approved applicators.

With these measures in place plus strict system protocol ONE AAC offers a warranty of 15 years on materials and 7 years on workmanship adding peace of mind to all owners. ONE AAC and associated manufacturers both adhere to the ISO 9001 international standards for management of quality.



The ONE AAC Panel System - BCA Compliance

The BCA is part of the Australian National Construction Code system and defines minimum standards for buildings. The BCA consists of two volumes:

Volume One - provides requirements for commercial, residential and public building defined as Class 2 to 9 in the BCA. Typical examples include offices, commercial, health buildings, flats and boarding houses.

Volume Two – Housing Provisions, considers domestic construction defined as Class 1 and 10. Typical examples include houses, garages, swimming pools, carports and the like. The BCA is a performance based building code and contains requirements for Structures, Fire Resistance; Damp & Weatherproofing, Sound Transmissions & Insulation and Energy Efficiency.

The ONE AAC Panel System has been assessed to meet and comply with all the necessary performance requirements of the BCA. This design & Installation Manual contains the information necessary to assist in the design of a project.

The designer should ensure the proposed use of the system satisfies the Performance Requirements and provides sufficient design information (including ONE AAC appraisal and installation manuals) to satisfy the requirements of the appropriate authority.

ONE AAC Panel has achieved the CODEMARK CERTIFICATE OF CONFORMITY issued by Global-Mark in Australia (Certificate Number GM_CM30031 Rev 1) to meet all the required provisions of the Building Code of Australia **for Volume One and Volume Two** and has been appraised as an **Alternative Solution** in terms of compliance with the Building Code of Australia as listed below:



1. **Volume One BP1.1, BP1.2, B1.4 and Volume Two P2.1.1, 3.5.4.0** in respect of structural performance;
2. **Volume One A5.4, C1.1, C1.9 and Volume Two 3.7.2.4, 3.7.3.2/5 and 3.7.4.3** in respect of fire performance;
3. **Volume One FP1.4, F1.9 and Volume Two P2.2.2** in respect of damp weatherproofing;
4. **Volume One F5.2/3/4/5 and Volume Two 3.8.6.2/3/4** in respect of acoustic performance;
6. **Volume One G5.2 and Volume Two 3.10.5.0(c)** in respect of Construction in Bushfire Prone Areas;
7. **Volume One J1.5 and Volume Two 3.12.1.4** in respect of Building Fabric Thermal Insulation;

The Code Mark Certificate is attached in the Appendix of this Design and Installation Manual or visit www.oneaac.com.au to download a copy.

Standard Compliance

All works shall be carried out in accordance with the Building Code of Australia (BCA) and where necessary nominated reference standards.

AS 1720 Timber Framing Code and AS 1684-2006 National Timber Framing Code

AS 2870-1996 Residential Slabs and Footing Construction and AS 3600-2001 Concrete Structures

AS 3959-2009 Construction of Buildings in Bushfire-Prone Zone Areas

AS 2904-1995 Damp-proof course and flashings

AS 1170 Part 1 Loading Code and AS 1170 Part 2 Wind Code

AS 3660.1-2001 Protection of Buildings against subterranean Termite – Part 1 New Buildings

AS 4055-2006 Wind Loading for Housing

AS 3623 and AS/NZ 4600 – Steel Framing and NASH Standard 2005, Part 1 – Steel Framing

Where standards have been revised, the most current version shall apply

For a copy of the relevant compliance documents visit our website: www.oneaac.com.au

ONE AAC Construction Overview

The ONE AAC Panel System is designed to be used in new residential construction, extensions or re-cladding for houses & Multi-Residential External Walls using timber or steel frames as well as infill walls in high rise construction. The system consists of either 50mm or 75mm thick ONE AAC Panels, reinforced with corrosion protected steel in both directions, installed horizontally in a “stretcher-bond” pattern over continuous vertical battens attached to the load bearing frame. For fast, clean construction.

ONE AAC Panels are available in standard sizes of 2200mm in length and 600mm for easy of handling. Longer lengths are available, but the handling and weight of the panels must be considered when selecting longer panels.

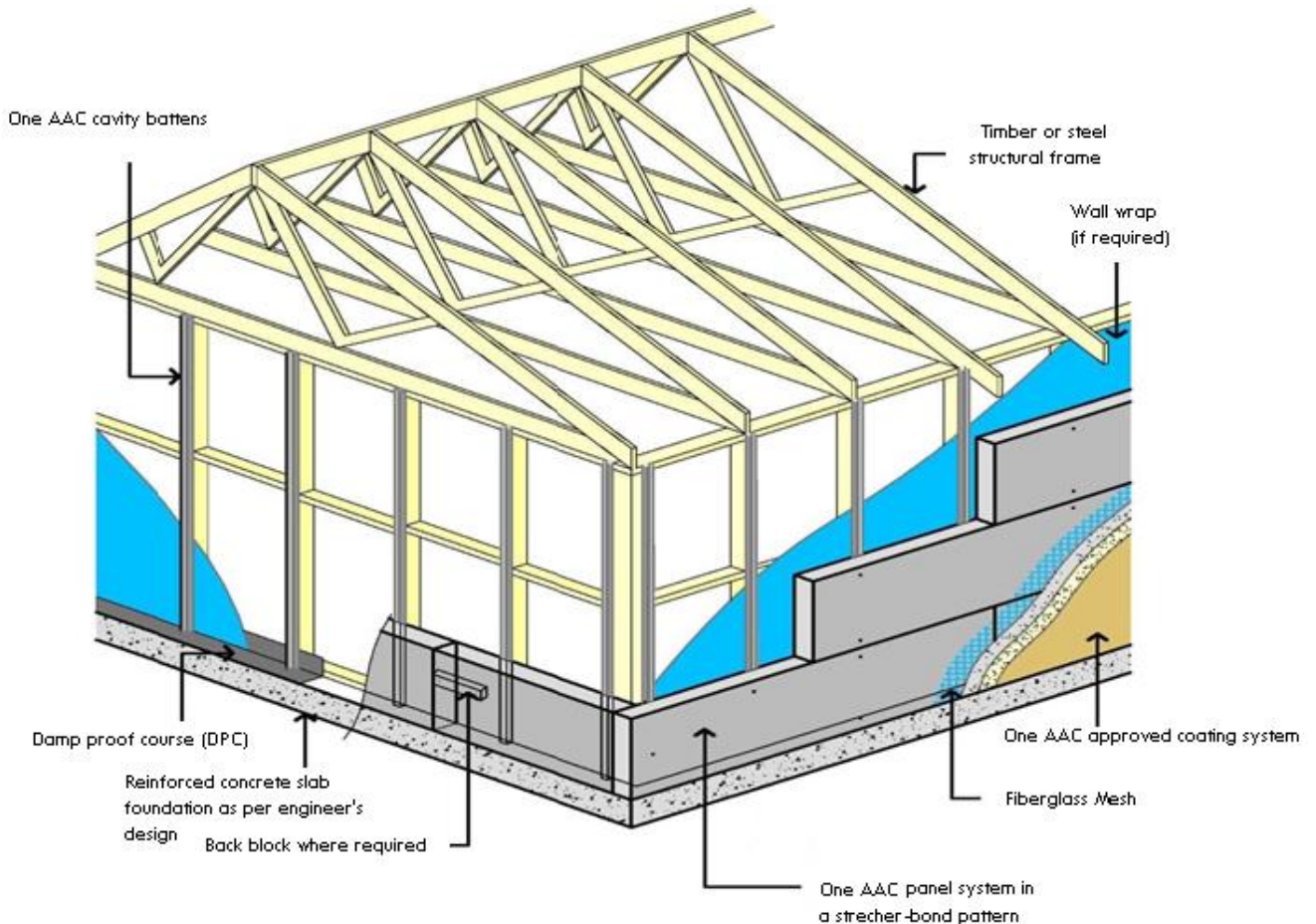

CONSTRUCTION OVERVIEW – Applicable to both 50mm and 75mm ONE AAC Panel

Structure

Wind loads on the building are transferred from the panels to the frame through the fixing and batten system. The frame is the structural component of the wall system, therefore the structural loads including bracing and hold-down requirement for the frames should be designed in accordance with the BCA and the relevant Australian Standards.

Mass

The 50mm ONE AAC Panel has an average mass of 30.5kg/m² (40kg per panel) and the 75mm ONE AAC Panel has an average mass of 55kg/m² (72kg per panel) without coatings. In most cases the panel weight is supported at the base. In the event that the panels are suspended, the designer/engineer's must allow for the weight of the panel being fixed to the frame in the design and computation process. Within the computations, 4kg/m² should be allowed for external coatings.

Note: Suspended installation is not permitted with polystyrene battens or when using 75mm panel with metal cavity battens greater than 40mm in depth.

Wind Zone

When installed in accordance with this Design & Installation Manual, The ONE AAC Panel is able to be designed to perform in wind zones up to and including N5, C3. The ONE AAC Panel System has been appraised for being suitable for use in buildings subjected to design wind speed as defined in AS 4055. The system is designed to meet the performance requirements in the BCA Section B of Volume One and clause P2.1 of Volume Two.

In other wind speed areas, the system can be used up to the ultimate limit state (ULS) wind pressure of 2500Pa when designed specifically in accordance with the BCA.

Note: Although the ONE AAC Panel System is considered a drainable non-ventilated cavity system, it is beneficial to seal the doors and window frame junctions, particularly in high wind zone areas and coastal areas.

The following Table 2 identifies the required batten spacing and panel fastener spacing for the wind zones as described in the BCA: (Ref to drawing on page 28 for batten and panel screw spacing's)

TABLE	Max Horizontal Spacing For Battens and Panel Screws		Max Panel Screw Spacing Vertically	
	Corner Zone	Typical Zone	Corner Zone	Typical Zone
Wind Zone	Corner Zone	Typical Zone	Corner Zone	Typical Zone
N2, N3, C1	600	900	500 (2 screws/600mm)	500 (2 screws/600mm)
N4, C2	600	600	250 (3 screws/600mm)	500 (2 screws/600mm)
N5, C3	450	450	250 (3 screws/600mm)	250 (3 screws/600mm)

Impact Resistance

The system has adequate resistance to impact loads that the cladding system is likely to be subjected to when used in a residential situation.

Durability

The durability of a product or system refers to the ability of that product or system to be used in its intended application for a defined period of time. AAC products have been used in the building industry worldwide for several decades, and continue to be recognized for their performance, particularly durability. The ONE AAC Panel System subjected to normal conditions of environment and use will meet the durability requirements of S1.2.1 of the BCA.

External Moisture

The ONE AAC Panel System is designed to prevent the penetration of water that could cause undue dampness and/or damage to building elements, but in the event that water is able to penetrate into the cavity, the system is also designed to allow excess moisture present to be dissipated without causing permanent damage to the building elements, and therefore complies with Performance requirements of the BCA P2 .2.2

The technical details provided for weather proofing are based on the design principle of employing both a 1st and 2nd line of defence against moisture entry. Firstly, moisture ingress must be prevented by detailing any joinery or wall junctions as shown in this Design & Installation Manual. Secondly, in the event that water does penetrate the wall system, a drainable cavity ensures and maintains weather proofing.

Any weather proofing details developed by a designer that are outside the scope of this Design & Installation Manual are the responsibility of the designer.

For all external wall applications, (other than a boundary wall with no penetrations), the presence of a drained cavity does not reduce the requirement to ensure the ONE AAC Panel System and all the relevant junctions, penetrations etc. remain weather proof in order to comply with Clause P2.2.2 of the BC A. In the event that a wall is built on a boundary (with no penetrations) and is abutting the walls of the adjoining property and cannot be coated, the uncoated ONE AAC Panel System will act as a drained cavity system and will therefore comply with Performance requirement of the BCA for drained cavity systems.

Fire Resistance

AAC materials have exceptional fire resistance and are non-combustible. In the event of fire ONE AAC Panels will not emit any toxic gases or vapours. The ONE AAC Panel System meets the performance requirements of P2.3.1 of the BCA for use as a Load Bearing External Wall, providing an FRL of 120/120/90 using 10mm plasterboard internal lining or 120/120/120 using 13mm fire rated plasterboard internal lining– (All tests and opinions were conducted by CSIRO, for Copies of Fire Reports or Opinions, contact ONE AAC on 1300 010 222).



Photo courtesy of www.budwell.com

Compliance with the Bush Fire Zone Requirements

The ONE AAC Panel System complies with all six Bush Fire Attack Level categories and is therefore rated as **BAL-FZ (Flame Zone)** for external cladding. ONE AAC is a non-combustible material and exceeds an FRL of 30/30/30 when tested from the outside, as per AS3959-2009 Construction of Buildings in Bush Fire-Prone Areas.

There are Six (6) Bushfire Attack Levels, ranging from Low to Flame Zone; these are as per table below

BAL	DESCRIPTION	REQUIREMENTS FOR EXTERNAL WALLS	ONE AAC PANEL
Low	Minim attack from radiant heat and flame. Some attack by burning debris is possible.	No special construction requirements.	✓
12.5	Attack by burning debris is significant with radiant heat not greater than 12.5kW/m2. Specific construction requirements for ember protection and accumulation of debris are warranted.	Non-combustible material required to base of external walls up to 400mm above ground or decks.	✓
19	Attack by burning debris is significant with radiant heat not greater than 19kW/m2. Specific construction requirements for ember protection and accumulation of debris are warranted.	Non-combustible material required to base of external walls up to 400mm above ground or decks.	✓
29	Attack by burning debris is significant with radiant heat not greater than 29kW/m2. Specific construction requirements for ember radiant heat are warranted. Some flame contact is possible.	Non-combustible material	✓
40	Radiant heat levels and flame contact is likely to significantly threaten building integrity.	Non-combustible material or tested for bushfire resistance to AS 1530. 8.1	✓
FZ (Flame Zone)	Significant radiant heat and significant higher likelihood of flame contact from the fire front will threaten building integrity.	Non-combustible material with a minimum thickness of 90mm or an FRL of -/30/30 when tested from outside or to be tested for bushfire resistance to AS 1530.8.2	✓

Compliant with the Bush Fire Zone Requirements (continued)

The standard defines the construction requirements for external walls as:

<p>9.4.1 Walls</p> <p>Walls shall be one of the following:</p> <ul style="list-style-type: none"> a) Walls made of non-combustible material (e.g. masonry, brick veneer, mud brick, aerated concrete and concrete) with a minimum of 90mm in thicken ss. or b) A system complying with AS1530.8.2 when tested from the outside or c) A system with an FRL of 30/30/30 or –/30/30 when tested from the outsider or d) A combination of any of Items (a), (b) or (c) above
--

“Reproduced with permission from SAI Global Ltd under Licenses 1204-c05 6”, to purchase the Standard online visit www.saiglobal.com

For a copy of the Fire Test Certificate, contact us on 1300 010 222

Energy Efficiency

The ONE AAC Panel System is able to achieve very good thermal performance (R-Values) as Thermal Mass and Thermal Resistance. The R-Value can be related to the comfort levels within a dwelling, the greater the R- Value the more comfortable the temperature will be within that dwelling. The ONE AAC Panel System easily achieves the Thermal requirements as set out in P2.6.1 of the BCA.

For a copy of the reports for the stated R-Values, contact us on 1300 010

ONE AAC SYSTEM	System details – 70mm Frames The following Systems are all based on 50mm/75mm ONE AAC Panel, 20-40mm Cavity, 70mm Frame Thickness, and 10mm Plasterboard internal linings	Total R Value m2K/W	
		Summer 50mm/75mm	Winter 50mm/75mm
NS-1-70	Panel + Cavity + No Sarking + Frame + No Insulation + Plasterboard	0.72/0.89	0.74/0.91
SS-1-70	Panel + Cavity + SS Sarking + Frame + No Insulation + Plasterboard	1.33/1.50	1.46/1.63
NS-2-70	Panel + Cavity + No Sarking + Frame + R2.0 Insulation + Plasterboard	2.63/2.80	2.84/3.01
SS-2-70	Panel + Cavity + SS Sarking + Frame + R2.0 Insulation + Plasterboard	2.63/2.80	2.84/3.01

ONE AAC SYSTEM	System details – 90mm Frames The following Systems are all based on 50mm/75mm ONE AAC Panel, 20-40mm Cavity, 90mm Frame Thickness, and 10mm Plasterboard internal linings	Total R Value m2K/W	
		Summer 50mm/75mm	Winter 50mm/75mm
NS-1-90	Panel + Cavity + No Sarking + Frame + No Insulation + Plasterboard	0.72/0.89	0.74/0.91
SS-1-90	Panel + Cavity + SS Sarking + Frame + No Insulation + Plasterboard	1.34/1.51	1.50/1.67
NS-2-90	Panel + Cavity + No Sarking + Frame + R2.0 Insulation + Plasterboard	2.63/2.80(min)	2.84/3.01(min)
NS-3-90	Panel + Cavity + No Sarking + Frame + R2.5 Insulation + Plasterboard	3.11/3.28(min)	3.24/3.41(min)
SS-2-90	Panel + Cavity + No Sarking + Frame + R2.5 Insulation + Plasterboard	3.11/3.28(min)	3.24/3.41(min)
DS-1-90	Panel + 40mm Cavity + DS Sarking + Frame + R2.5 Insulation + Plasterboard	3.49/3.66	3.83/4.00
FS-1-90	Panel + Cavity + FS Sarking + Frame + R2.0 Insulation + Plasterboard	5.00/5.17	5.20/5.37

Notes: SS = Single Sided Sarking; NS = No Sarking; DS= Double Sided Anti-Glare Foil Sarking; Higher Values can be achieved using foil or air bubble type sarking and or alternative insulation (contact ONE AAC for more information).

Air Tightness

The prevention of airflow and drafts within the cavity significantly assist in the thermal performance of a wall system. The ONE AAC Panel System is non-ventilated, therefore reducing drafts that could occur within the activity, hence significantly improving Thermal Performance.

Insulation

To increase the R-Value and therefore comfort level, the use of insulation materials is recommended. The insulation should be installed to form a continuous barrier in accordance with the BCA.

Sarking Wall Wrap

The use of sarking although not mandatory with the ONE AAC Panel System, is considered good building practice. Sarking not only assists in controlling condensation, it creates an additional layer of air within the wall, which helps close the cavity, and greatly improves Thermal Insulation and Energy Efficiency. If sarking is required to provide a weatherproofing function, it should comply with AS/NZS4200 Parts 1 and 2.

Acoustic Performance

The ONE AAC Panel System offers good acoustic performance. To significantly increase the acoustic performance against outside noise, the use of sound insulation materials is recommended.

- The Bare 50mm ONE AAC Panel has an $R_w = 33$
- The Bare 75mm ONE AAC Panel has an $R_w = 35$

ONE AAC SYSTEM	The following Systems are based on 50mm/75mm ONE AAC Panel , no sarking, one layer of R1.5 insulation batts, and 10mm Plasterboard internal linings	Acoustic Rating	
		R_w 50mm / 75mm	$R_w + C_{tr}$ 50mm / 75mm
70-20	70mm Timber Frame + 20mm Cavity Battens	45 / 47	41 / 41
70-40	70mm Timber Frame + 40mm Cavity Battens	45 / 47	42 / 42
90-20	90mm Timber Frame + 20mm Cavity Battens	45 / 47	42 / 42
90-40	90mm Timber Frame + 40mm Cavity Battens	45 / 47	42 / 42
76-20	76mm Steel Frame + 20m Cavity Battens	53 / 55	46 / 46
76-40	76mm Steel Frame + 40m Cavity Battens	53 / 55	47 / 47
92-20	92mm Steel Frame + 20m Cavity Battens	53 / 55	47 / 47
92-40	92mm Steel Frame + 40m Cavity Battens	54 / 56	48 / 48

Stated Acoustic Values have been provided by Acoustic Engineers. For a copy of the acoustic reports, contact us on 1300 010 222

Design Principles for the ONE AAC Panel System

The design principles for the ONE AAC Panel System are based on those used for residential framed construction.

Frame Design

The support structure (stud frame) shall be designed by the frame manufacturer or the relevant design engineer, and should be designed in accordance with the specific framing codes for timber or steel frames.

Timber Frames

The timber framing must comply with the relevant Parts of AS1684 for both buildings, and parts of buildings. Studs should be sized as normal to suit the wind loadings, vertical loading and stud height in accordance with the BCA. Timber studs should be spaced at nominal 600mm centre's. Noggins must be flush fitted at a maximum of 1350mm centre's.

Steel Frames

The steel framing must comply with NASH Standard 2005, Part 1 Residential and low-rise steel framing. For steel framing the minimum framing specification is 'C' section studs and noggins of overall section size 76mm web and 32mm flange. Minimum Steel thickness must be 0.75mm in accordance with AS 3623 and AS/NZ4600

Bracing

The timber or steel framed walls must be braced for a medium weight wall cladding in accordance with AS 1684 for timber framing and AS3623 and AS/NZS4600 for steel framing.

Design Detail Considerations

Wall Lengths

Using the ONE AAC Panels System is fast and economical, with reduced waste being a significant advantage of the system. Knowing that the ONE AAC panels are 2200mm long and installed in a "stretcher- bond" pattern, designing a building in 275mm modules will assist in ensuring project efficiency.

Wall Heights

Knowing that the ONE AAC panels are 600mm in width and are installed in rows up the wall, the wall height (from the base of the panel to 30mm above the eave) should be designed (as close as possible) in 300 mm modules which will also assist in ensuring project efficiency.

Footings

ONE AAC panels can be a direct substitute for a thin sheet cladding material e.g. fibre cement sheeting or polystyrene cladding and fixed over 16-48mm cavity battens on timber or steel frames. The panels can be supported on a rebated step down, or alternatively they can be fixed overhanging the concrete slab or timber base. (Refer. The ONE AAC Panel System Drawings; on pages 31 and 32). The footings should comply with AS 2870 1996 Residential Slabs and Footing construction.

Termites

Although termites do not eat or nest in AAC, termite protection is still a mandatory requirement. The simplest method of termite protection is the 75mm exposed slab edge perimeter method. Due to the variation in requirements from state to state in Australia it is the builder's responsibility to ensure that all council and BCA requirements are met with regards to termite attacks. Refer to BCA 2011 Vol. 2 Part 3.1.3 and reference code AS3660, requirements for the management and termite risk.

Vertical Control Joints

Vertical control joints (articulated Joints) are located at internal corners and as per geotechnical engineer's design report (Soil Report). If the distance between corners exceeds 6m, control joints should be located in line with window and door openings. These joints require 5-10mm gaps between panels which are injected with expandable foam or backing rod and sealed with approved moisture compatible external grade flexible sealant. (Refer. The ONE AAC Panel System Drawings on page 51)

Multi Storey Construction

ONE AAC Panels can be used for multi-storey construction when fixed in accordance with the ONE AAC Panel System details. (Refer. The ONE AAC Panel System Drawings on pages. 33 and 34)

Horizontal Joints

Horizontal control joints are required:

- When the wall height exceeds 8 meters;
- When timber joists are not seasoned (greater than 1% shrinkage of the floor joist depth as confirmed by the timber manufacture), these Joints require a minimum gap of 20mm;
- If the horizontal joint is within the FLOOR JOIST ZONE.

(Refer. The ONE AAC Panel System Drawings on pages 32, 33, 34 and 51)

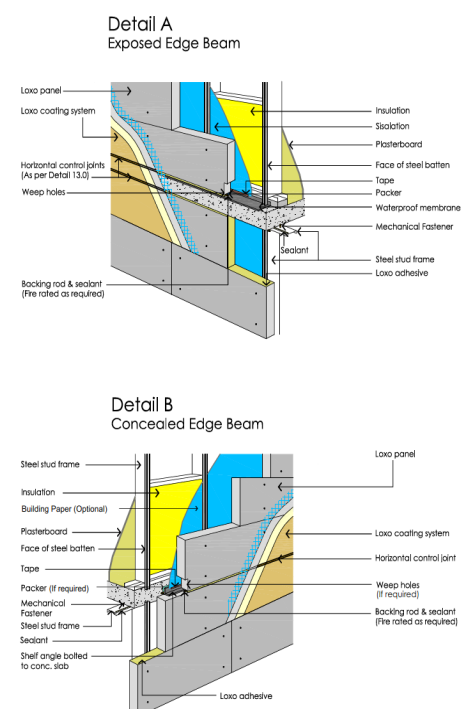
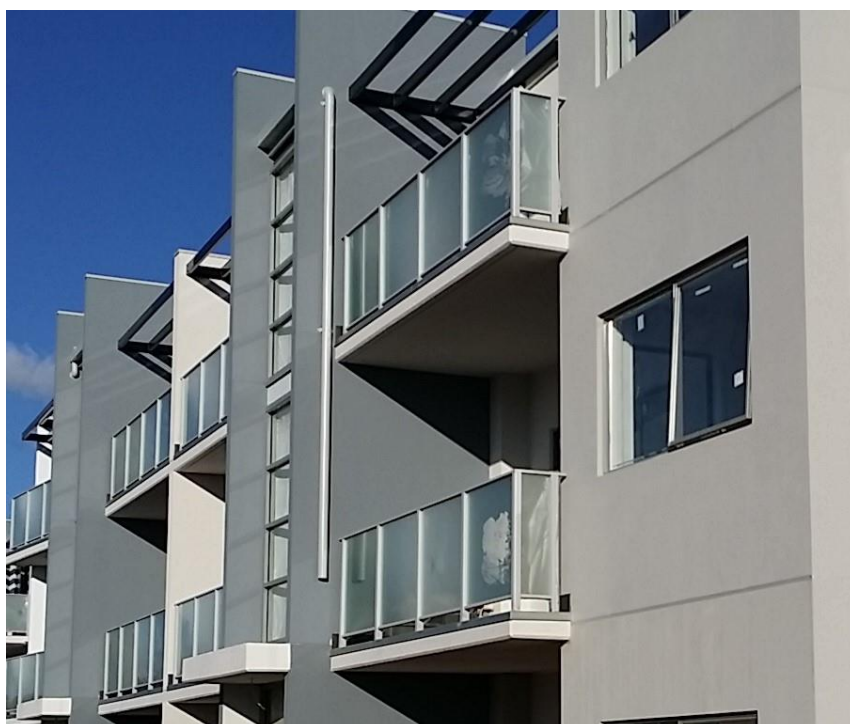

ONE AAC Panel System Components

ONE AAC Cavity Battens

(Refer. The ONE AAC Panel System Drawings on pages 25 and 26)

Cavity battens are manufactured from either:

- 0.42 BMT, G300 Galvanized Metal
- H3 treated pine timber, or
- Very High Density (Class VH) EPS with a density of no less than 28kg/m³

16mm to 48mm Cavity Battens supplied in 3000mm continuous lengths

ONE AAC Cavity Batten Fixing Requirements

- 2.87mm x 50mm (glue coated, plain shank galvanized nails) used to fix the 20mm timber battens to timber frames. (fix battens at 300mm centers);
- 3.05mm x 75mm (glue coated, plain shank galvanized framing nails) used to fix the 40mm timber battens to timber frames. (fix battens at 300mm centers);
- 12 x 40mm galvanized drill point countersunk screws used to fix the 20mm timber battens to steel frames. (fix battens at 300mm centers);
- 12 x 60mm galvanized drill point countersunk screws used to fix the 40mm timber battens to steel frames. (fix battens at 300mm centers);
- Construction Adhesive such as Max bond, Liquid Nails or similar may be used to temporarily fix the EPS battens to the frame or building wrap;
- 12-11 x 25mm Hex Head Type 17 screws used to temporarily fix the metal battens to timber frames; (fix battens at 600mm centers);
- 10-16 x 16mm Hex Head Takes screws used to fix temporarily the metal battens to metal frames; (fix battens at 600mm centers);

Note: A minimum of Class 3 fasteners must be used with the ONE AAC Panel System. A S3566 corrosion class 3 fasteners must be used in BCA defined corrosion zones 1, 2, 3, and 4. Class 4 or Grade 304 stainless steel in the sea spray zone.

ONE AAC Vermin Control /Cavity Closure Strips

(Refer. The ONE AAC Panel System Drawings on page 25)

Metal Vermin Control Strips; or Cavity Closer Strips are continuous metal battens used to close the gap between the bottom plate and the back of the panel. Mitre cut battens at corners to maintain vermin proofing. The battens are fixed to the bottom plate at 900mm centre's using:

- 12-11 x 25mm Hex Head Type 17 screws for timber frames;
- 10-16 x 16mm Hex Head Teak screws for steel frames;

Timber Vermin Control Strips; or Cavity Closer Strips are continuous timber Cavity Battens used to close the gap between the bottom plate and the back of the panel. Mitre cut or butt timber battens at corners to maintain vermin proofing. The battens are fixed to the bottom plate at 900mm centre's using hot dipped galvanized steel flat head nails.

ONE AAC Panels

The ONE AAC Panels are steel reinforced and are manufactured from autoclaved aerated concrete with a dry density of 520kg/m³-560kg/m³. The 50mm and 75mm thick ONE AAC Panels are supplied in a standard length of 2200mm and a standard width of 600mm, and have an average mass of approx. **40kg/panel for the 50mm thick panels** and approx. **72kg/panel for the 75mm thick panels**.

ONE AAC Panel Fasteners

Panels Fixed to Battens Only (Timber Battens)

- For wind zones up to and including N3, C1, the panel fasteners may be fixed into the timber battens without having to be fixed into the frame, provided the timber battens have been fixed to the frames using screws at a minimum of 600mm centers or as per the ONE AAC Cavity Battens Requirements.
- For wind zone greater than N3, C1, the panel fasteners must penetrate into the wall frame a minimum of 25mm for timber frames.

Panels Fixed Through Battens in to Frame (Polystyrene or Metal Battens)

- For all wind zones when using Polystyrene or Metal Battens, the panel fasteners must penetrate the wall frame a minimum of 25mm for timber frames and a minimum of 5 screw threads for metal frames.

For 50mm One AAC Panels

- 14-10 x 75mm MP Bugle Head Type 17 screws must be used to fix the panels into the timber battens or into steel frames (up to 0.75 BMT) with battens up to a maximum cavity thickness of 16mm
- 14-10 x 100mm MP Bugle Head Type 17 screws must be used to fix the panels through the 16mm cavity battens into the timber frames or to fix panels to steel frames (up to 0.75 BMT) with battens up to a maximum cavity thickness of 40mm
- 14-10 x 125mm MP Bugle Head Type 17 screws must be used to fix the panels through the 35mm cavity battens into the timber frames

For 75mm One AAC Panels

- 14-10 x 100mm MP Bugle Head Type 17 screws must be used to fix the panels into the timber battens or into steel frames (up to 0.75 BMT) with battens up to a maximum cavity thickness of 16mm
- 14-10 x 125mm MP Bugle Head Type 17 screws must be used to fix the panels through the 16mm cavity battens into the timber frames or to fix panels to steel frames (up to 0.75 BMT) with battens up to a maximum cavity thickness of 35mm
- 14-10 x 150mm MP Bugle Head Type 17 screws must be used to fix the panels through cavity battens greater than 35mm, with the Bugle Head screw embedding a minimum of 25mm into the timber frames once embedded in the ONE AAC Panel.

Notes:

- A minimum of Class 3 fasteners must be used with the ONE AAC Panel System. AS3566 corrosion class 3 fasteners must be used in BCA defined corrosion zones 1, 2, 3, and 4. Class 4 or Grade 304 stainless steel in the sea spray zone.
- Bugle Head Fasteners fixed through the face of the panels must be embedded a minimum of 5mm into the panel to comply with the corrosion requirements.

ONE AAC Panel Adhesive

The ONE AAC Panel Adhesive is a polymer modified cement-based adhesive supplied in 20kg bags. It is supplied by ONE AAC, mixed on-site with clean water (see instructions printed ONE AAC bag), and is applied to all edges of the panels (except control joint). ONE AAC Panel Adhesive is also used for bonding Decorative Trims and banding, along with minor patching, repairs and stopping of screw heads on the ONE AAC panels.

ONE AAC Corrosion Protection Touch Up Paint

When the ONE AAC Panels are cut to size, ensure that no reinforcing steel is exposed to openings or corners. When reinforcing steel is exposed it must be treated with the ONE AAC Corrosion Protection Touch Up Paint. It is supplied in 200ml containers. The instructions for use are on the container.

Damp Proof Course (DPC) & Flashing

- DPC is used to prevent rising damp from concrete footings, slabs or paths wetting the base of the panels.
- All flashings should be specifically designed for the wall frames and be compatible with the ONE AAC Panel System.
- Damp-proof courses should comply with the BCA, including AS 2904-1995 Damp-proof course and flashings.
- The designer should detail any specific requirements for special back-flashings required where the ONE AAC Panel joins another substrate/cladding

Sarking

Although the use of sarking is not mandatory with the ONE AAC Panel System, it is good building practice to do so.

However, sarking is required between:

- EPS battens and the frame to prevent condensation
- Metal battens and CCA treated timber frames to prevent corrosion of the metal batten.
- Metal battens and some LOSP treated frames to prevent corrosion of the metal batten. In the event that LOSP frames are to be used with metal battens, it is the responsibility of the project manager to confirm with the timber frame supplier if sarking is required to prevent corrosion of the metal battens.

Construction Adhesive

Construction Adhesive such as Max bond, Liquid Nails or similar should be used for adhering accessories such as Aluminum External Corner angles to ONE AAC Panels, or temporarily fixing EPS Cavity Battens prior to the installation of the panel fasteners.

Flexible Sealant

An external grade flexible sealant such as Bostik Seal'N'Flex or equivalent should be used at control joints, around windows, doors and penetrations through the ONE AAC Panels, to prevent or reduce the amount of water ingress into the cavity. Before sealant application, check with sealant manufacturer to confirm if a primer is required when using over ONE AAC Panels.

Fire Rated Sealant

An external grade fire rated sealant such as Knauf BINDEX, Fullers FIRESOUND Fire Rated Acoustic Sealant or Bostik FIREBAN ONE Low Modulus Fire Rated Polyurethane Sealant or equivalent must be used in control joints in all fire rated wall applications such as boundary walls.

System Installation Process

1. Ensure builder has completed the frame ready for the ONE AAC Panel System. A pre-cladding check list is available on our website: www.oneaac.com.au
2. DPC must be applied to foundation and up-stand as per the ONE AAC Panel System Details.
3. Check to ensure framing is straight and plumb with a straight edge, especially corner studs.
4. If specified, install the required wall wrap in accordance with the BCA and manufacturer's instructions.
5. For suspended applications (as per the ONE AAC Panel System Details) install ONE AAC vermin control cavity closers as required.
6. Batten Installation:
 - a. firstly, start by fixing continuous horizontal battens approx. 75mm below & above openings to the extent and including the jamb studs prior to fixing vertical battens.
 - b. then, fix the battens vertically as per specifications from the bottom plate in line with the studs.
 - c. Repeat the process for 6a and 6b above. The horizontal distance between battens must comply with the structural requirements for the Wind Zone of the project; refer to Table 2 on page 9. Extra battens can be placed to allow for irregularities in framing or in anticipated extra support for the ONE AAC Panels.
7. Starting from a corner, place the first ONE AAC Panel horizontally onto the rebate. Use a spirit level to ensure the ONE AAC Panel is level and is either flush or overhanging the rebate as required. Push the ONE AAC Panel hard against the battens and screw fix through the exterior face, through or into the batten as specified to a minimum of 50mm in from the edges of the ONE AAC Panel. A minimum of 6 screws are required per standard ONE AAC Panel and each screw must be wound into the ONE AAC Panel until the head is embedded by a minimum of 5mm. ONE AAC Panels can be cantilevered a maximum of 500mm beyond the stud and to ensure that the panels are aligned, back blocking is required.
8. Apply ONE AAC Panel Adhesive approximately 2–3mm thick along the vertical edge of the ONE AAC Panel. Abut the next ONE AAC Panel hard against the fixed ONE AAC Panel. Ensure this ONE AAC Panel is level and screw throughout or into the battens as specified to a minimum of 50mm in from the edges of the ONE AAC Panel. Repeat this procedure around the perimeter of the building.
9. Apply ONE AAC Panel Adhesive approximately 2–3mm thick along the top edge of the first row of ONE AAC Panels for approximately one panel length. Lay the next row of ONE AAC Panels with a minimum of 275mm stretcher-bond overlap of the ONE AAC Panel below, then screw ONE AAC Panel as outlined above. For panel layout guidelines, refer to the ONE AAC Panel System Drawings on page 27
10. ONE AAC Panels may be cut to size and whenever possible no reinforcing steel should be exposed to openings or corners. All exposed steel reinforcement must be treated with ONE AAC Corrosion Protection Touch Up Paint.
11. Apply ONE AAC approved sealant to window and door jambs surrounds as per specification.

The ONE AAC Panel System installation must be performed or supervised by approved installers to ensure quality of workmanship.

ONE AAC Panel Installation Summary

1. Wall Frame is completed and ready for panel installation.
 - Plumbing and electrical should be installed within the frame, and it is preferred if the services are installed after panel installation



2. Install Flashing.
 - Ensure that DPC or flashing is installed correctly
 - If sarking is being installed, it should be lapped over the flashing, prior to batten installation.



3. Batten Installation
 - Select cavity batten size and type, i.e. Metal/Timber/EPS
 - Install horizontal battens below and above openings
 - Install Vermin Control Battens if required.



4. Install ONE AAC Panel
 - Install in a stretcher bond pattern
 - Minimum of 6 screws per standard panel
 - Back Block all off stud panel joints
 - Adhesive to be applied to vertical and horizontal joints
 - Cut panels to suit
 - Exposed reinforcement to be coated with ACP
 - Minimum panel stagger of 275mm
 - Glue and screw external corners

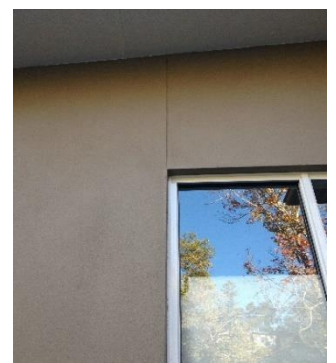
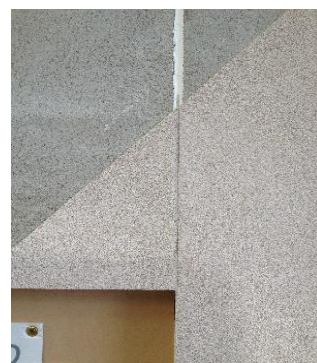

5. Ensure approved coating system is applied. (Fully Meshed)

Plumbing and Electrical Services

Services are preferred to be installed through the frame but they can be fixed to the outside of the frame in a horizontal direction between the battens typically 300mm up from the bottom of the first row of panels, or as agreed between the builder and the Panel Installer. Service penetrations through the ONE AAC Panel should be neatly cut, and allowing a 5 to 10mm clearance gap around the penetration, which must be sealed with an approved external grade sealant. PVC sheathed electrical cables must be prevented from direct contact with the EPS Battens and must be placed in a conduit.

Basic Tools Required When Working With AAC

The basic tools required when working with AAC are typically used by the carpentry and rendering trades and are readily available and relatively inexpensive when it comes to the complete set up for working with AAC.

Some of the tools required to make the job easy are identified below:

- ◆ Personal Protective Equipment
 - ✓ High Visibility Work Wear, Steel Cap Boots
 - ✓ Gloves, Dust Mask, Goggles, Hearing Protection
- ◆ Standard Contractor Tools
 - ✓ Hammer, Nail Bag, Tape, Pencil, Level
 - ✓ Tin Snips, Chisels, Knife
 - ✓ Electric Leads and Power Box
- ◆ Power Saw
 - ✓ Preferably Dustless
 - ✓ Fitted with a Diamond Blade
- ◆ Vacuum
- ◆ Power drill / Mixing Drill / Mixing Buckets
- ◆ Cordless Drills and Drive Bits
- ◆ Grinder / Reciprocator Saw
- ◆ Adhesive Trowel
- ◆ Hawk and Steel Trowel
- ◆ Nail or Staple Gun
- ◆ Sanding Float / Rasp



ONE AAC Approved Coating System

Only ONE AAC Approved Coating Systems are to be applied over ONE AAC Panels. For a complete list of ONE AAC Approved Coating Systems, visit our website: www.oneaac.com.au

Components

An Approved ONE AAC Coating System typically comprises:

- ◆ A specially formulated cement based, polymer modified Base Coat Render System;
- ◆ A fiberglass reinforcing mesh troweled and embedded into the Base Coat Render;
- ◆ A Wet or Dry Texture, typically applied directly over the Base Coat Render;
- ◆ A Top Coat Membrane Paint System (typically, two coats of membrane applied over the Texture)

Notes:

- ✓ A Primer between the Base and the Texture or between the Texture and the Top Coat may be required? (please check with the coating manufacturers specific requirements).
- ✓ The ONE AAC Panel System demands the use of External Corner Angle for that true perfect finish.

Specification

Pre-Coating Requirement

Before commencing application of the coating system, the coating applicator must ensure that all required penetrations have been carried out and that the ONE AAC Panels are suitably dry and ready for the coating application.

Coating System Application

All Coating Components used for the coating of the ONE AAC Cladding Panels are to be supplied by the ONE AAC approved coating manufacturer and or sub-contractors. The Coating System should be applied by contractors aligned and approved by the ONE AAC Approved Coating Partners. For a list of the approved Coating Partners, visit our website: www.oneaac.com.au

Meshed Base Coat Render

The Meshed Base Coat Render must be a polymer-modified, Portland cement-based render; it is mixed on site with clean drinking water. It is applied as a base coat, either over or encapsulating the fiberglass mesh reinforcement. Ensure there is a minimum of 2mm thickness over the mesh. The total meshed base coat should have a minimum thickness of 3mm.

The Reinforcing Mesh must be a high quality, alkali resistant fiberglass mesh with a nominal size of approximately 5mm square and a weight of 165g/m² for use in domestic and light commercial situations.

Primer Coat (Optional)

A water based primer/sealer to enhance adhesion can be applied if necessary. (Refer to coating manufacturer's specification for suitable primer coats that are compatible with this system)

Texture Coat: Two specifications for the Texture Coat material are available.

1. Dry Texture:

A cement based polymer modified coating applied with a trowel or float over the basecoat. The texture must have a minimum thickness of 1.0mm. It is mandatory to overcoat dry textures with an approved membrane paint system (Membrane Coating).

2. Wet Texture:

A pre-mixed, full acrylic coating, with a minimum thickness of 1mm, which is applied over the basecoat with a trowel or float. The Wet Textures may be coloured through (tinted) and may not require the application of a paint system (dependent on coating manufacturers recommendations and warranty). In the case were a paint system is not required, the application of the wet texture forms the primary means of weather resistance.

Paint System (Membrane Coating)

The paint system (membrane coating) must comprise a minimum of two coats of a 100% acrylic-based exterior membrane paint. The paint / membrane must be applied to a minimum dry film thickness of 150um per coat and must have a crack bridging capability of five (5) times the total dry film thickness. The application of the paint system forms the primary means of weather resistance.

Coating System Approval

Proprietary coating systems must be approved by ONE AAC prior to their use. The coating manufacturer must confirm that they comply with the ONE AAC Approved Coating System specifications and that they will provide a minimum 7 year manufacturer's warranty when used with the ONE AAC Panel.

Coating System Maintenance

Regular checks and cleaning, at least annually, of the Coating Systems must be carried out, and any routine maintenance performed as and when required to maintain weather tightness. Any damage to the Coating System must be promptly repaired by an approved coating applicator to ensure the integrity of the Coating System is maintained.



Delivery Storage & Handling

Delivery

ONE AAC Panels are flat-packed delivered to site (20 in a pack for 50mm Panel and 13 in a pack for 75mm Panel) and shall be unloaded or moved with approved lifting devices. For transport and lifting purposes the wet mass of the panels should be used. Each pack has a wet mass of approximately 900kg including the packaging. To minimise double handling and save time the packs should be unloaded as close as possible to the installation area. ONE AAC Panel packs should only be stacked one pack high (on site) and properly supported on level ground. Always consult the project engineer as to the adequacy of the structure to support the packs if they are to be placed on any part of the structure.

Storage

All ONE AAC material should be kept dry and preferably under cover, all care should be taken to avoid damage to the face, ends and edges of the panels. When ONE AAC Panels are stored outside they must be off the ground and protected from the weather.

Manual Handling

Physical manual handling of ONE AAC Panels around the work site should be kept to a minimum, always carry the panels on edge, and support the weight by a two man lift procedure. Where the manual handling becomes excessive with respect to distance from the installation area, ONE AAC recommends the use of trolleys and/or other mechanical devices.

Occupational Health & Safety (OH&S)

ONE AAC Panels, along with all clay, concrete and quarry products contain Crystal line Silica, or Silica Dust. Prolonged exposure to Silica dust without the correct Personal Protection Equipment can be harmful and potentially cause life threatening health hazards such as bronchitis, silicosis and lung cancer.

The ONE AAC Panel itself does not cause health problems, however when cutting, drilling, chasing, sanding, etc., the exposure to high volumes of dust is increased, which increases the potential for health problems to occur, unless standard precautionary measures are taken. Repeatedly breathing in high volumes of dust over many years, may lead to health problems.

It is most unlikely to breath in high volumes of fine silica dust when stacking, loading or laying panels, however when cutting, drilling, chasing, sanding, etc., it is imperative that safety masks, hearing and eye protection is worn. Ensure the mask fits properly and is approved for use with dust. Protective clothing should also be worn e.g. high visibility long sleeve shirt and long pants. These should be washed often and not in the same wash as other clothes.

The site should be cleaned of dust every day, and when using power tools these should be tagged for use as required and be fitted with efficient and well maintained dust extraction devices. The ONE AAC Panel Installer on site has a responsibility to inform all employees of these Health and Safety requirements under the Occupational Health and Safety Act.

Personal Protective Equipment (PPE)

When working with AAC, ONE AAC recommends (as a minimum) that the following PPE is worn:

- ◆ P1 or P2 Dust masks – complying with AS/NZS1715 and AS/NZS1716
- ◆ Glasses / Goggles - complying with AS1336
- ◆ Ear Plugs / Ear Muffs – Class 5
- ◆ Gloves, long sleeve shirt and pants – to prevent possible skin irritation and skin cancer from working outdoors
- ◆ Steel Cap Boots

Cutting

ONE AAC Panels can be easily cut, drilled, or chased using power or hand tools. When working with ONE AAC Panels ensure that the PPE as previously described is worn. As an added measure of containing the dust when working with AAC products, ONE AAC recommends the use of dust extraction equipment.

ONE AAC Panel makes cutting easier for the installer, as they are delivered to site flat packed, essentially each pack of panel is its own cutting bench, simply adjust the depth of the saw blade to the thickness of the panel, and cut the required panels before removing it from the pack. Any exposed reinforcement during cutting must be coated with the ONE AAC Panel Corrosion Protection Touch Up Paint. For a copy of the full range of ONE AAC Panel MSDS sheets, visit the website; www.oneaac.com.au

Hazardous Materials

With reference to the BCA, regarding Hazardous Building Materials, AAC Panels are non-hazardous, provided that all safety precautions included in this literature are adhered to.

Warranty & Guarantee

ONE AAC Panels are quality building products, and come with the following Warranty and Guarantee:

Warranty

ONE AAC Panels and associated materials, when installed as exterior wall cladding, are warranted for a minimum of **15 years** (from the date of purchase), not only meeting, but exceeding the **7 year** requirement outlined in the BCA and the relevant Australian Standards. The ONE AAC Panel products are designed to have a life span significantly in excess of this minimum period.

Guaranteed

ONE AAC Panel Autoclaved Aerated Concrete products are guaranteed to be free of defect in material and manufacture.

The ONE AAC Panel Approved Coating products are guaranteed by the coating manufacturers, for weatherproofing against peeling, flaking, cracking or deterioration, provided the system has been properly maintained and subjected to normal conditions of exposure.

The Coating Manufacturers guarantee applies only where all material components of the ONE AAC Panel Approved Coating System have been prepared and installed in accordance with their written instructions and technical specifications.

For further details or information on the engineering, design and construction with the ONE AAC Panel System, please contact our sales or technical professionals on 1300 010 222 or visit our website: www.oneaac.com.au to obtain the latest Design & Installation Manuals.

Drawings & Details

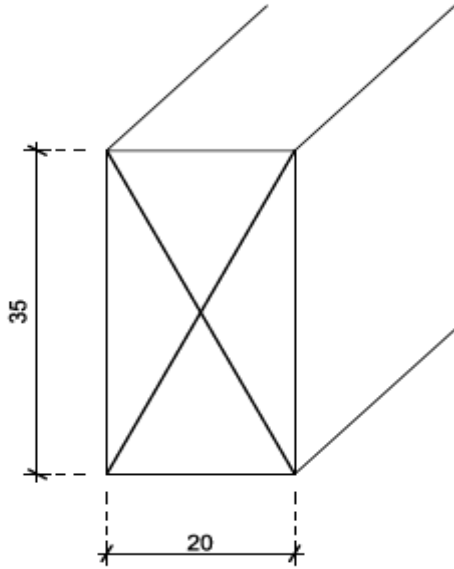

20mm TIMBER BATTEN
(H3. Treated)

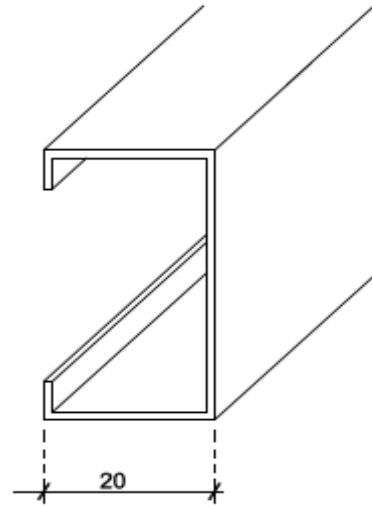

20mm METAL BATTEN

Note: The Loxo vermin control cavity closer is only required if the Loxo panel is not supported by a slab rebate (i.e. unenclosed sub-floor or overhanging the slab edge). It must be fixed continuously to the bottom plate of frame. The metal batten corners must be mitre-cut to maintain vermin proofing.

20mm CAVITY CLOSER

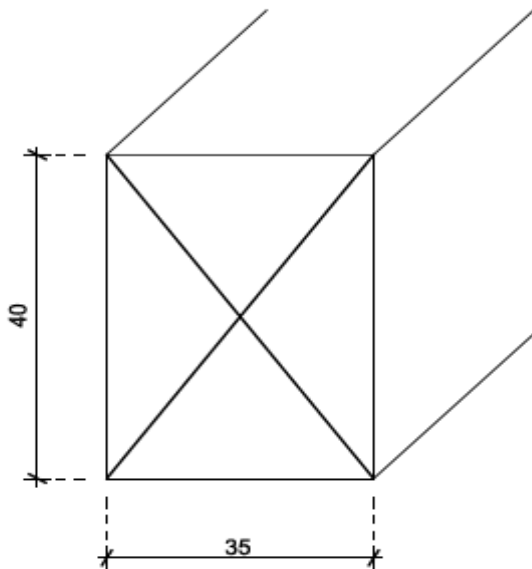

40mm TIMBER BATTEN
(H3. Treated)

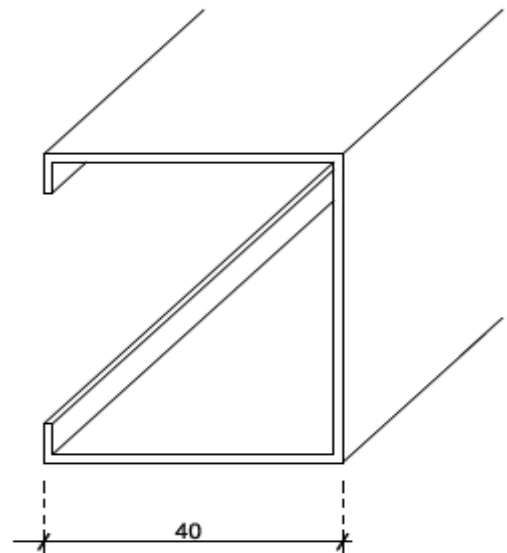

40mm METAL BATTEN

Note: The Loxo vermin control cavity closer is only required if the Loxo panel is not supported by a slab rebate (i.e. unenclosed sub-floor or overhanging the slab edge). It must be fixed continuously to the bottom plate of frame. The metal batten corners must be mitre-cut to maintain vermin proofing.

40mm CAVITY CLOSER

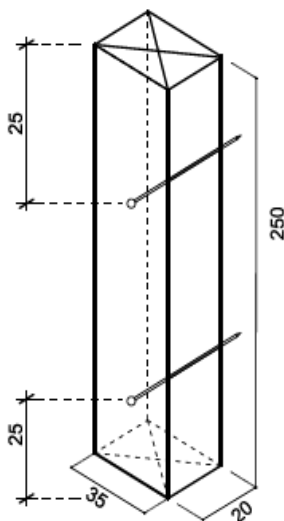

- H3 Treated timber
- 35 x 20 x (250mm or continuous)
- Battens fixed to timber frames using 2 x 50mm nails.
- Battens fixed to metal frames using 2 x 35mm drill point screws.
- Panels must be fixed into frame through timber battens using 100mm bugle batten screws.

Note:

It is good building practice to provide wall wrap (but not required)

20mm TIMBER BATTEN

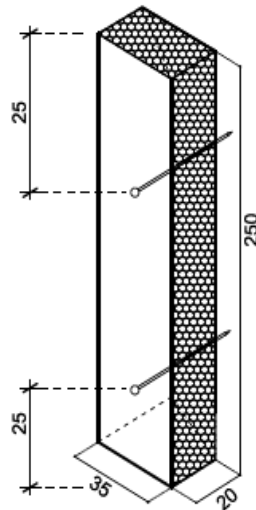

- VH EPS
- 35 x 20 x (250mm or continuous)
- Battens fixed to timber frames using 2 x 40mm galvanised clouts or fully glued over wall wrap using Loxo approved EPS adhesive.
- Battens fixed to metal frames using 2 x 40mm countersunk, drill point galvanised screws or fully glued over wall wrap using Loxo approved EPS adhesive.
- Panels must be fixed into frame through EPS battens using 100mm bugles.

Note:

When using EPS battens wall wrap is required.

20mm EPS BATTEN

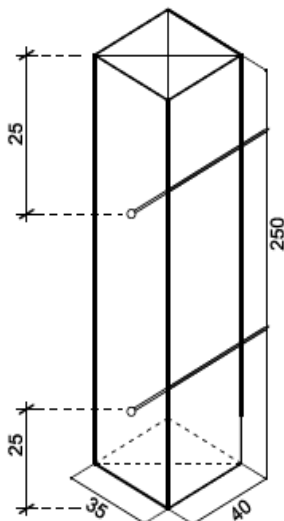

- H3 Treated timber
- 35 x 40 x (250mm or continuous)
- Battens fixed to timber frames using 2 x 75mm nails.
- Battens fixed to metal frames using 2 x 50mm drill point screws.
- Panels can be fixed onto timber battens (in low wind zones) using 75mm bugle screws or fixed onto the frame using 125mm bugle screws.

Note:

It is good building practice to provide wall wrap (but not required)

40mm TIMBER BATTEN

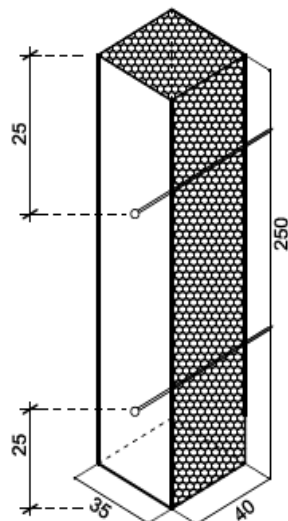

- VH EPS
- 35 x 40 x (250mm or continuous)
- Battens fixed to timber frames using 2 x 50mm galvanised clouts or fully glued over wall wrap using Loxo approved EPS adhesive.
- Battens fixed to metal frames using 2 x 50mm countersunk, drill point galvanised screws or fully glued over wall wrap using Loxo approved EPS adhesive.
- Panels must be fixed into frame through EPS battens using 125mm bugles.

Note:

When using EPS battens wall wrap is required.

40mm EPS BATTEN

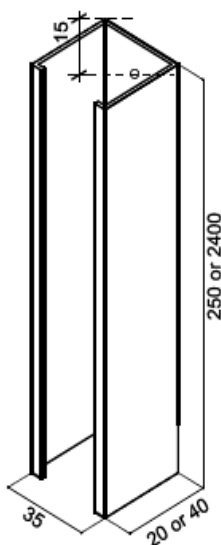

- 0.42mm Thick galvanised metal
- 35 x (20 or 40mm) x (250 or continuous)
- Battens fixed to timber frames using 25mm screws.
- Battens fixed to metal frames using 16mm drill point screws.
- FOR TIMBER FRAME**
- Panels must be fixed into timber frames through metal battens using 100mm bugle screws for the 20mm batten.
- Panels must be fixed into timber frames through metal battens using 125mm bugle screws for the 40mm batten.

Note:

It is good building practice to provide wall wrap (but not required)

FOR STEEL FRAME

- Panels must be fixed into steel frames through metal battens using 75mm bugle screws for the 20mm batten.
- Panels must be fixed into steel frames through metal battens using 100mm bugle screws for the 40mm batten.

20mm or 40mm METAL BATTEN

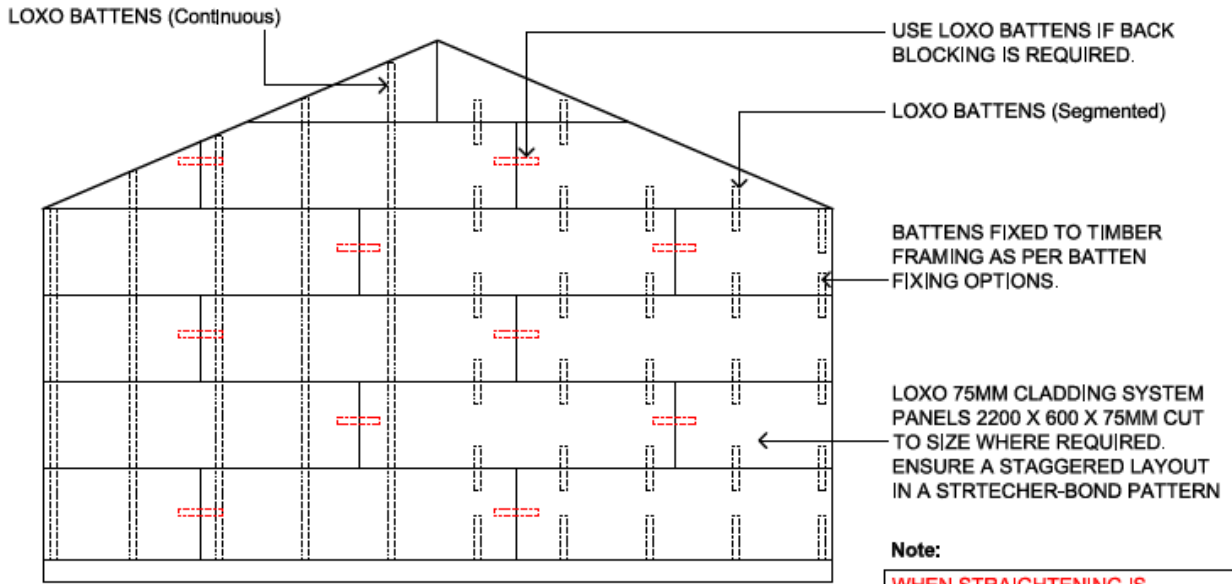

SINGLE STOREY PANEL ELEVATION

Note:

WHEN STRAIGHTENING IS REQUIRED A NON COMPRESSIBLE MASONITE, PLYWOOD OR PLASTIC PACKER MUST BE USED.

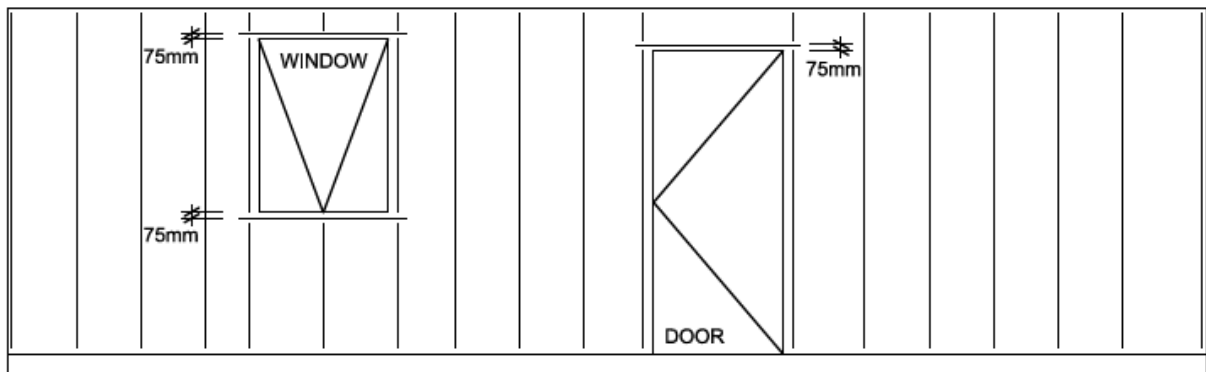

BATTEN LAYOUT GUIDELINE

NOTE: HORIZONTAL BATTENS INSTALLED APPROX. 75MM ABOVE AND BELOW OPENINGS.

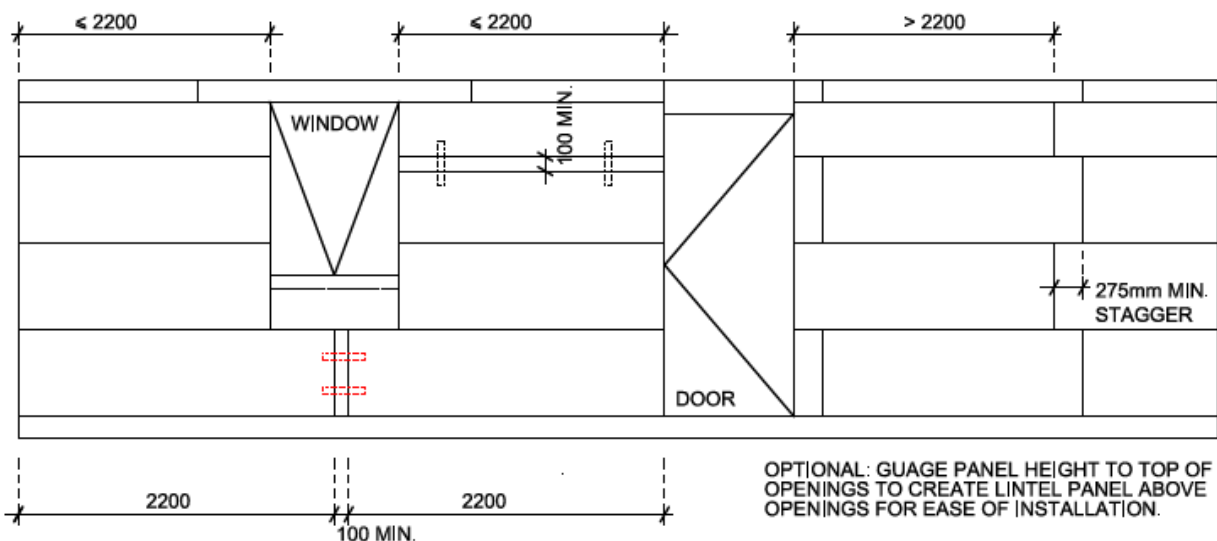

PANEL LAYOUT GUIDELINE

OPTIONAL: GAUGE PANEL HEIGHT TO TOP OF OPENINGS TO CREATE LINTEL PANEL ABOVE OPENINGS FOR EASE OF INSTALLATION.

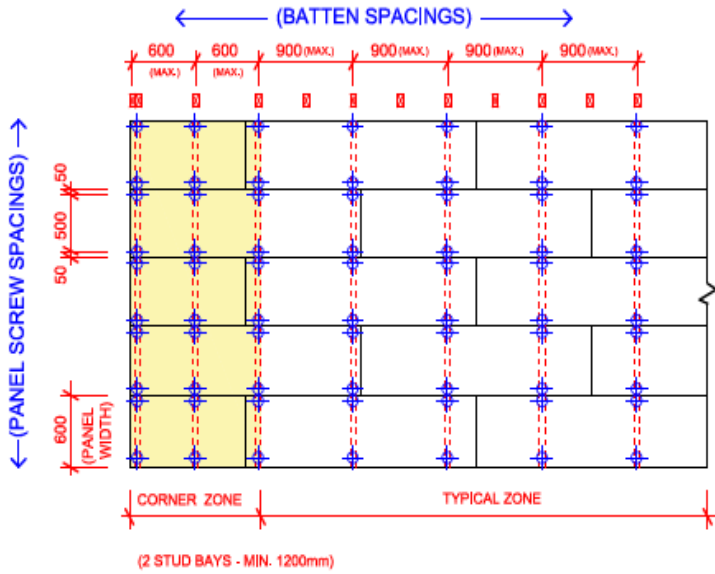

LEGEND

- ⋮ DENOTES BATTENS
- ⊕ DENOTES PANEL SCREWS (50mm MIN. FROM PANEL EDGE)

BATTEN & PANEL SCREW SPACINGS
(WIND ZONE N2, N3, C1 DEPICTED)

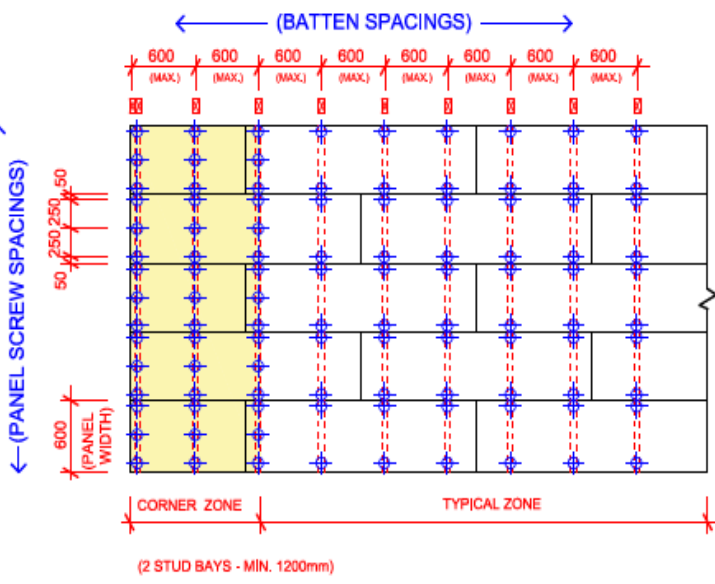

LEGEND

- ⋮ DENOTES BATTENS
- ⊕ DENOTES PANEL SCREWS (50mm MIN. FROM PANEL EDGE)

BATTEN & PANEL SCREW SPACINGS
(WIND ZONE N4, C2 DEPICTED)

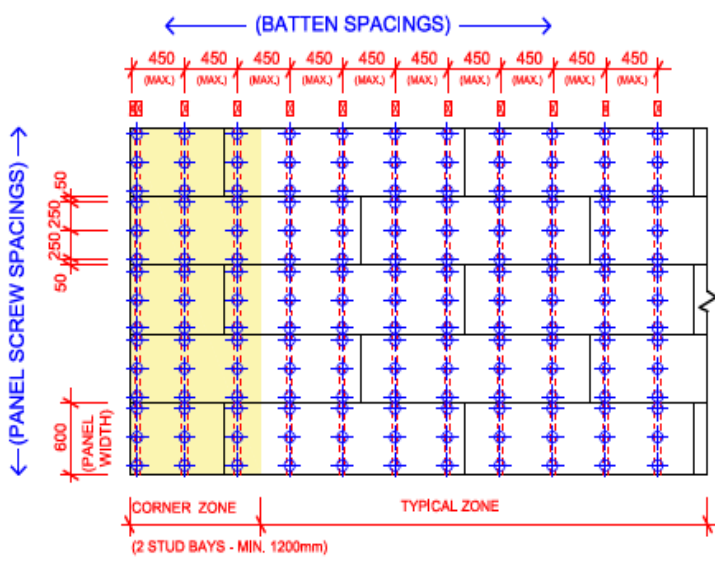

LEGEND

- ⋮ DENOTES BATTENS
- ⊕ DENOTES PANEL SCREWS (50mm MIN. FROM PANEL EDGE)

BATTEN & PANEL SCREW SPACINGS
(WIND ZONE N5, C3 DEPICTED)

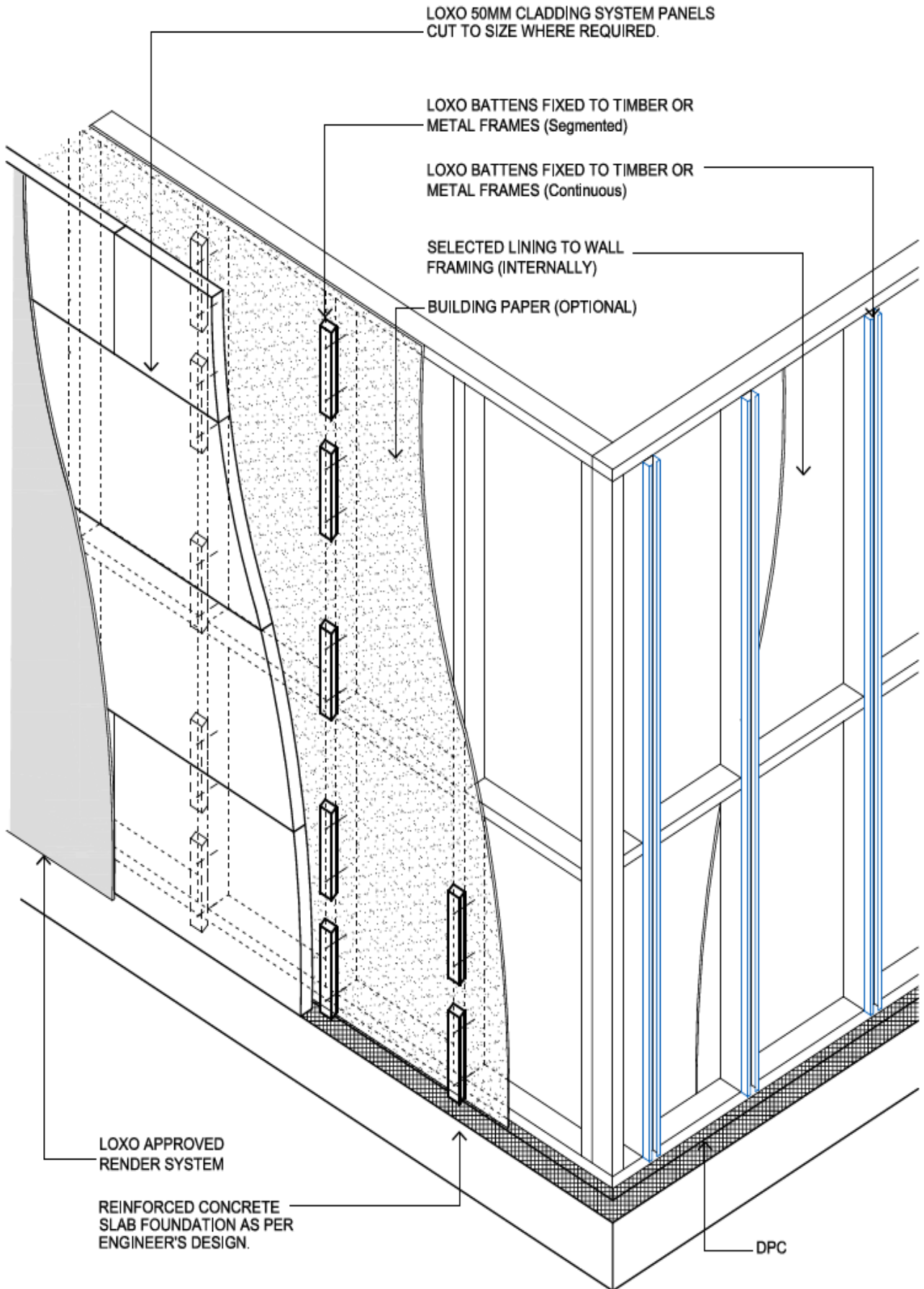

TIMBER OR METAL WALL FRAMING

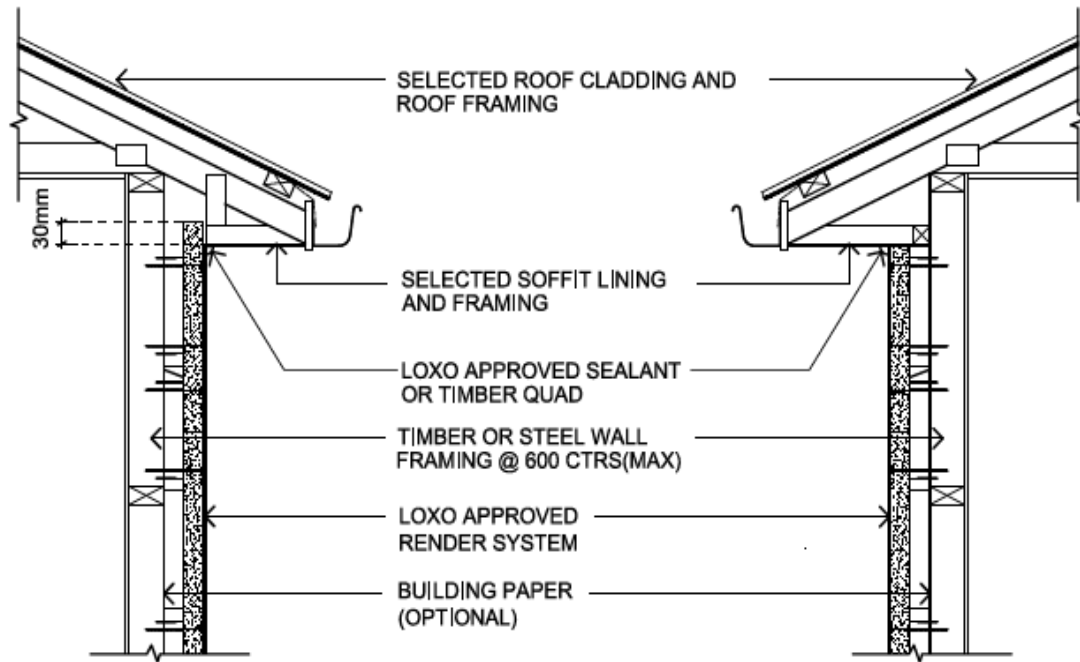

**OPTION 1
(PANEL ABOVE EAVE)**

**OPTION 2
(PANEL BELOW EAVE)**

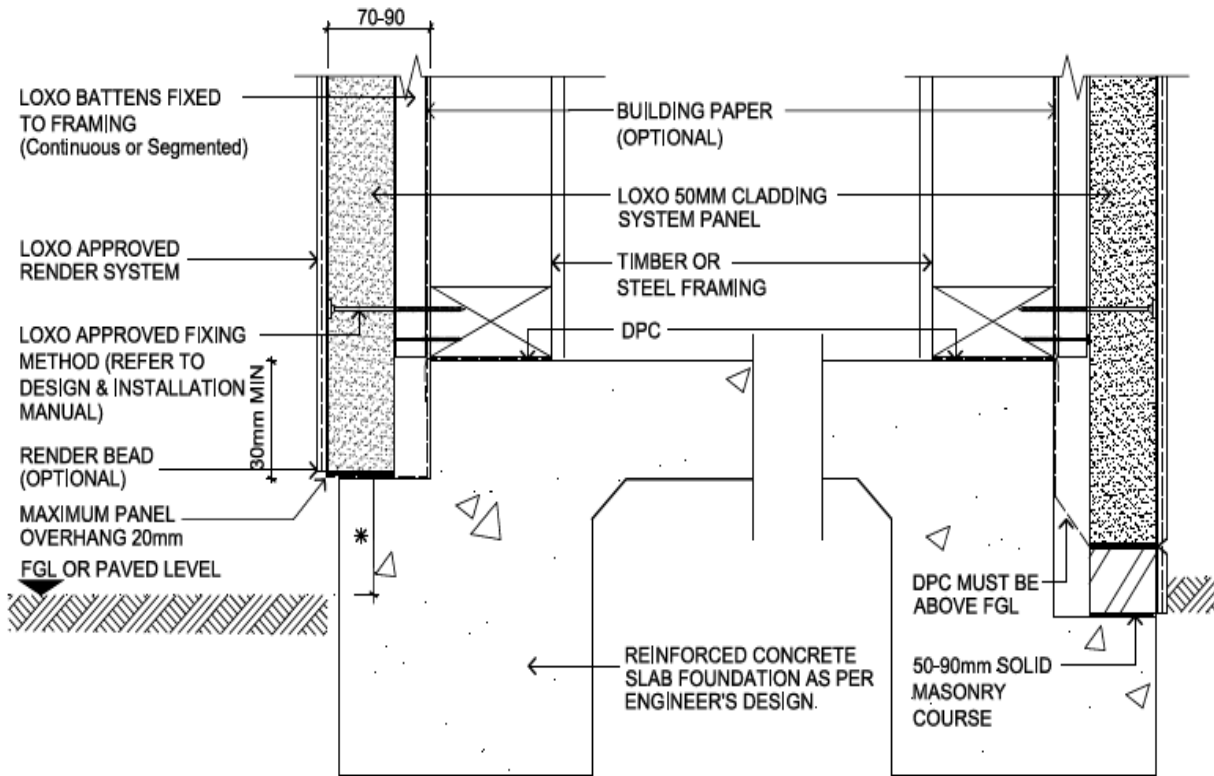

REBATED STEP-DOWN

REBATED STEP-DOWN WITH BRICK COURSE

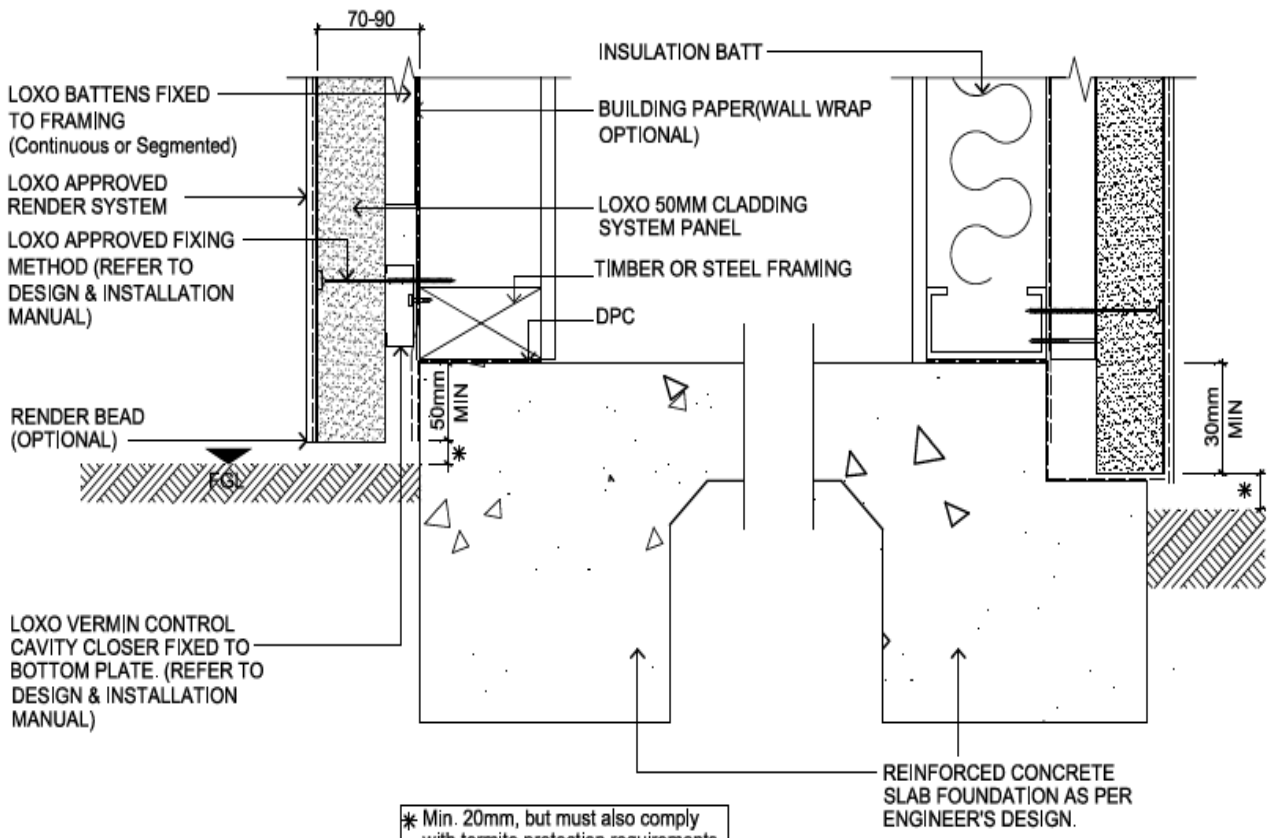

OVER-HANGING

REBATED FOUNDATION

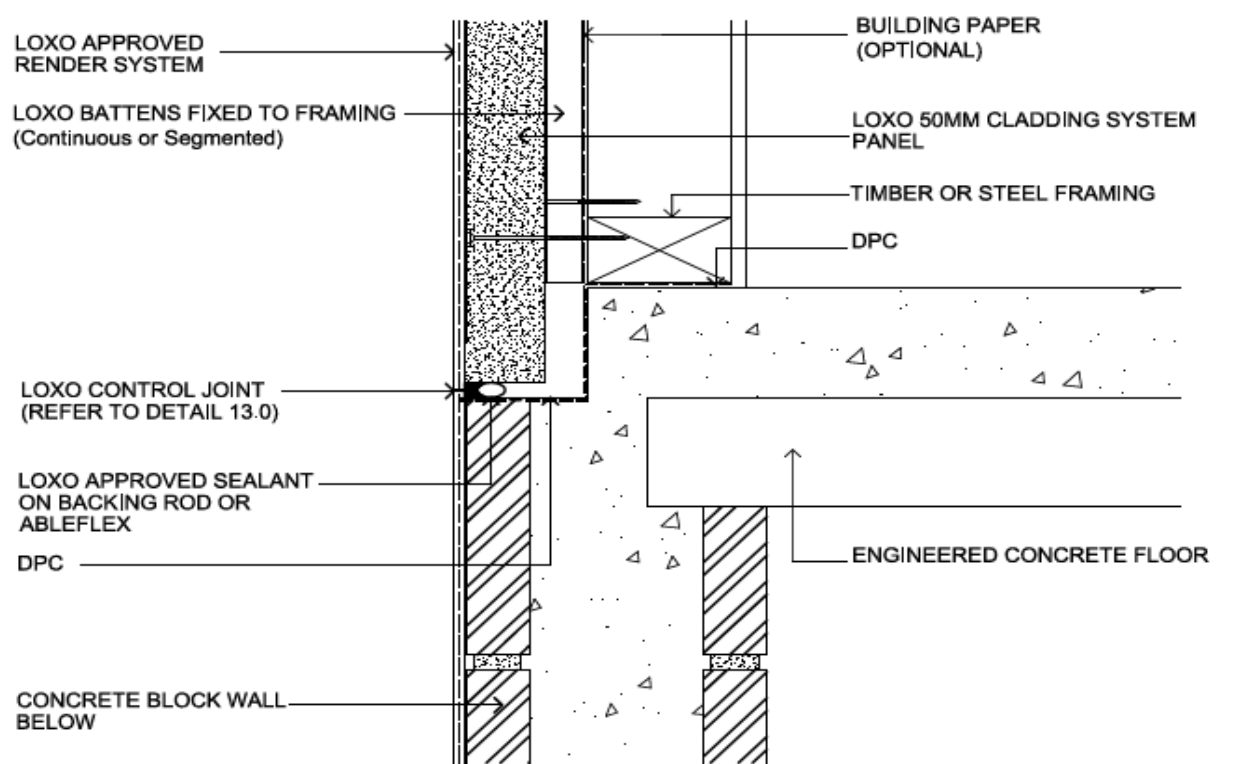
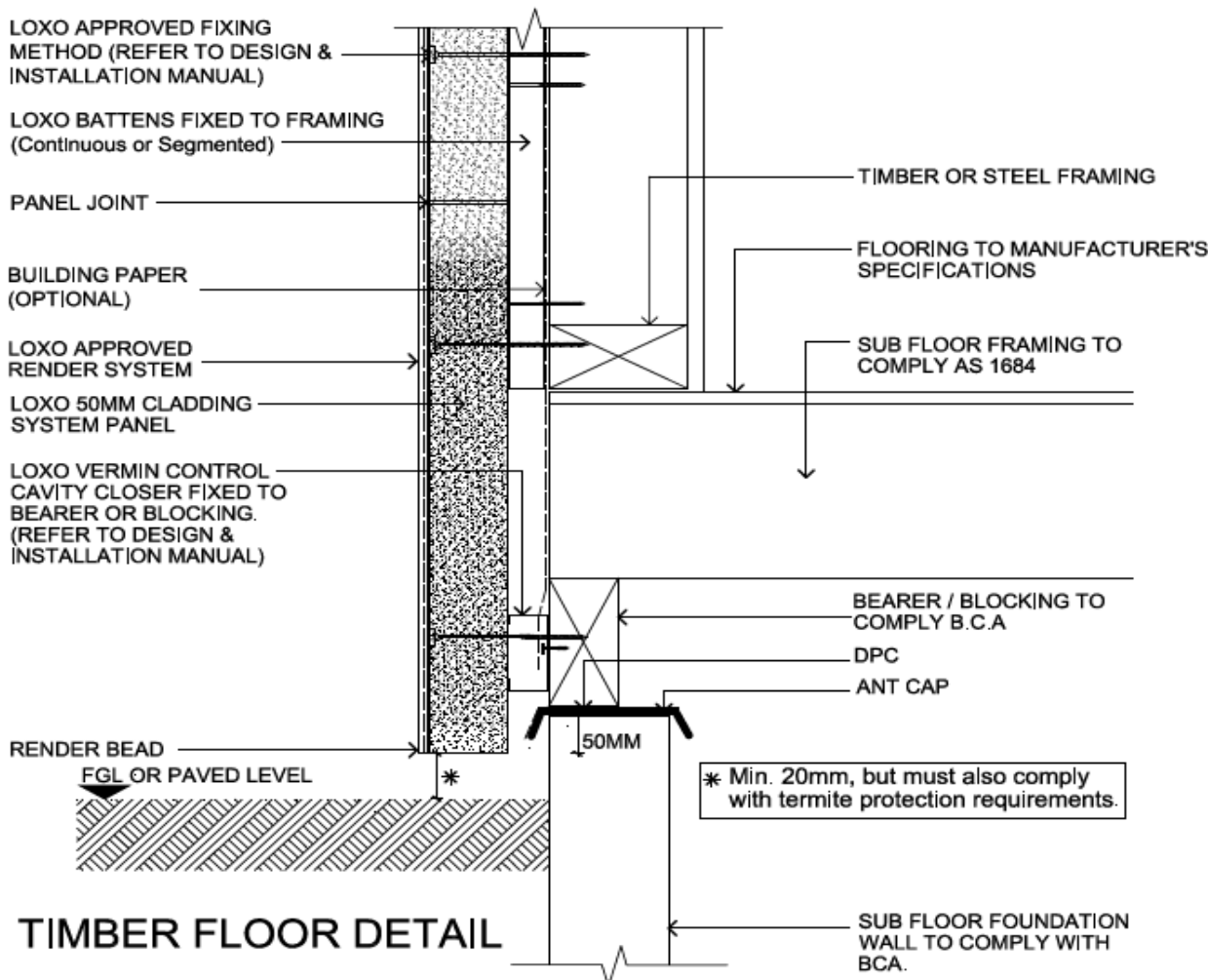

FIRST FLOOR CONCRETE DETAIL

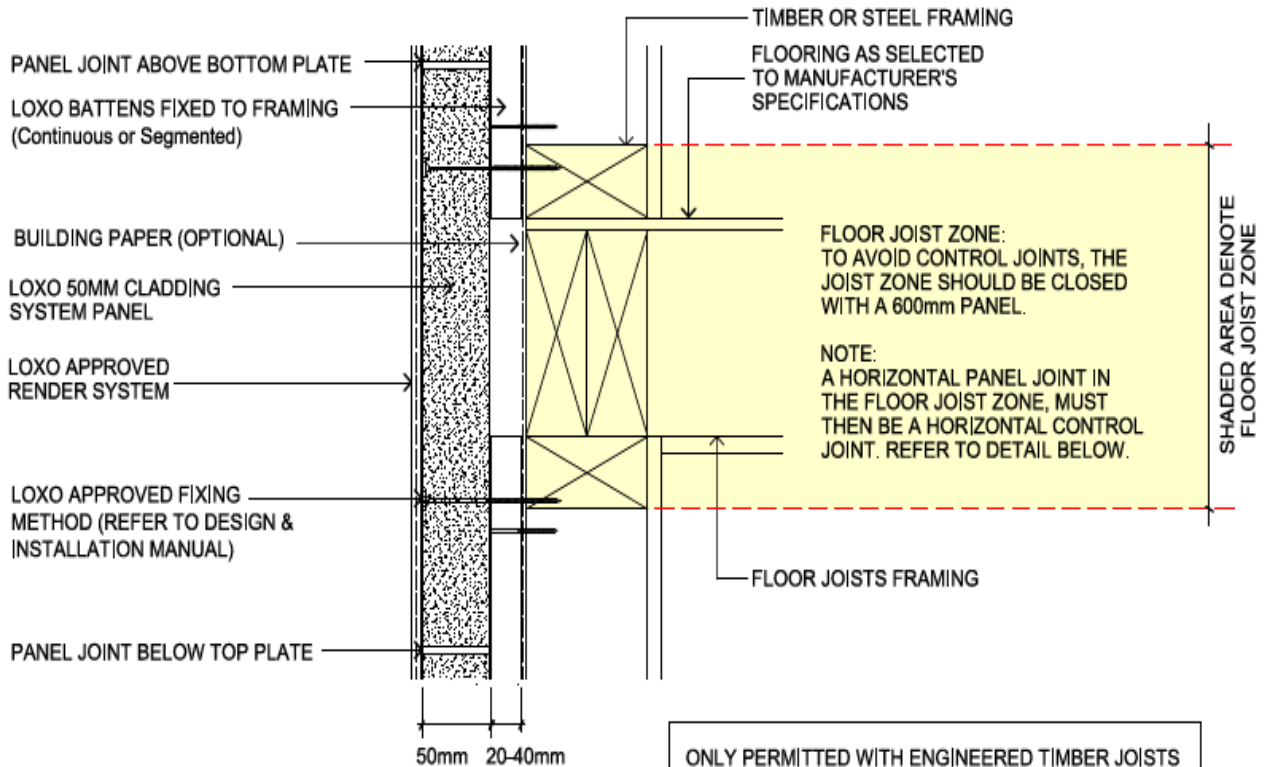

FLOOR JOIST ZONE DETAIL

(CONTINUOUS PANEL IN FLOOR JOIST ZONE)

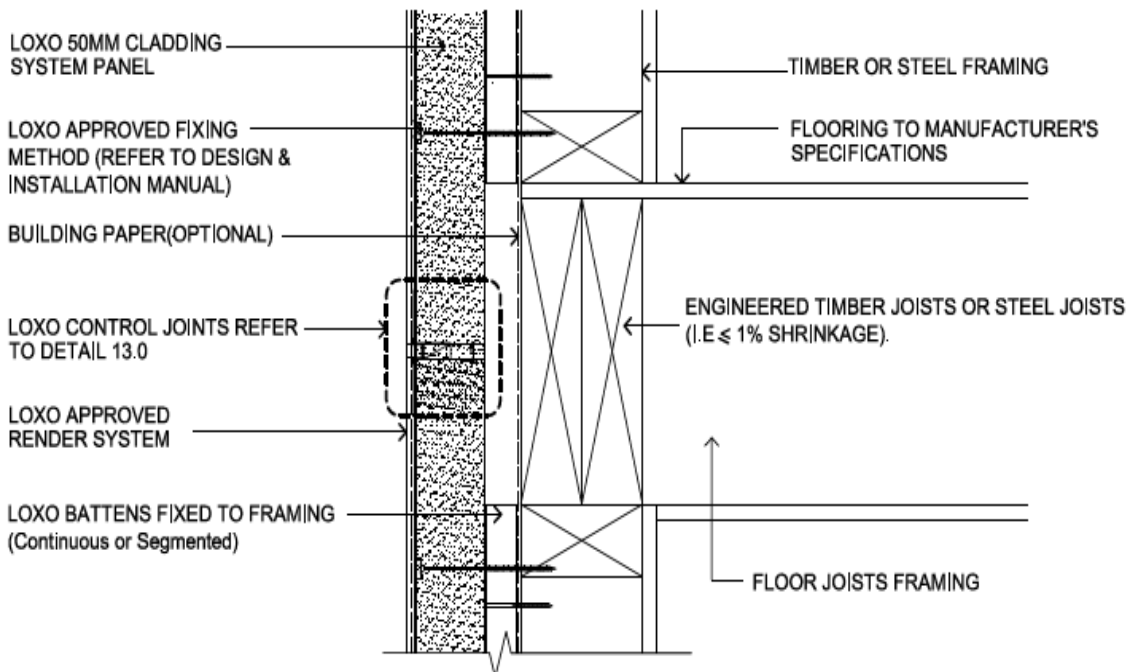

FLOOR JOIST ZONE DETAIL

(CONTROL JOINT IN FLOOR JOIST ZONE)

REQUIRED WHEN THE PANEL JOINT IS WITHIN THE FLOOR JOIST ZONE.

Detail A Exposed Edge Beam

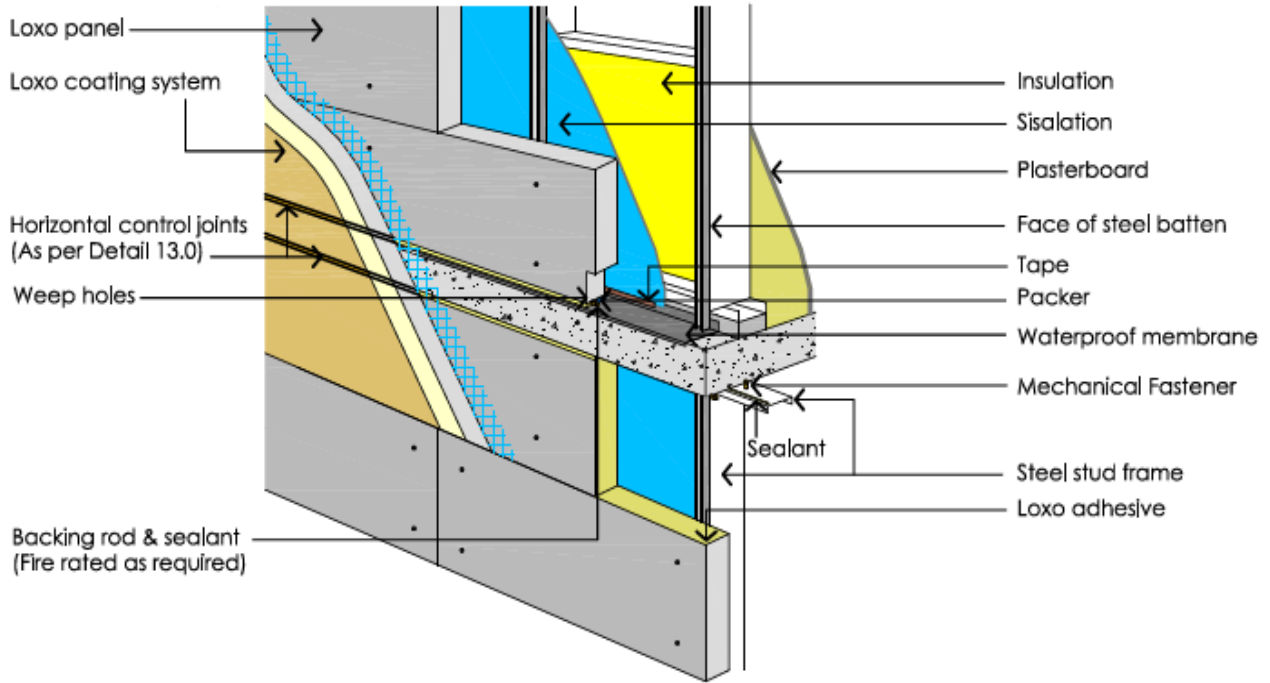

Detail B Concealed Edge Beam

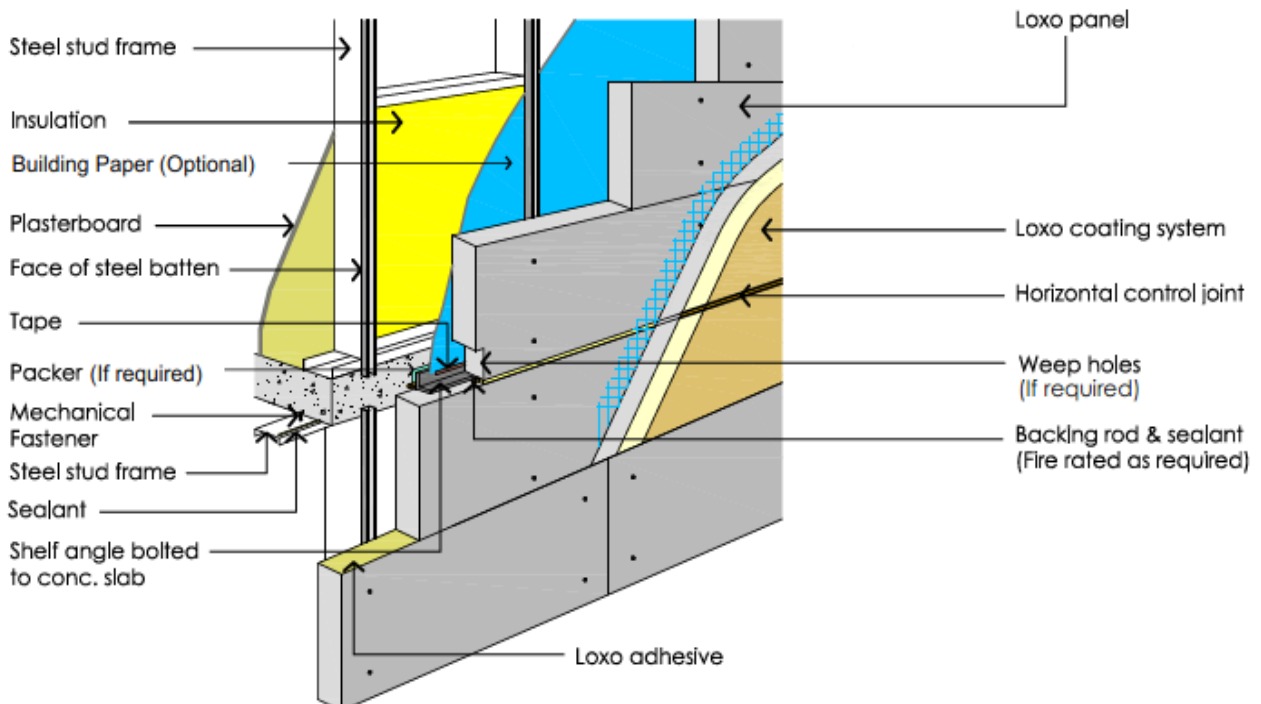

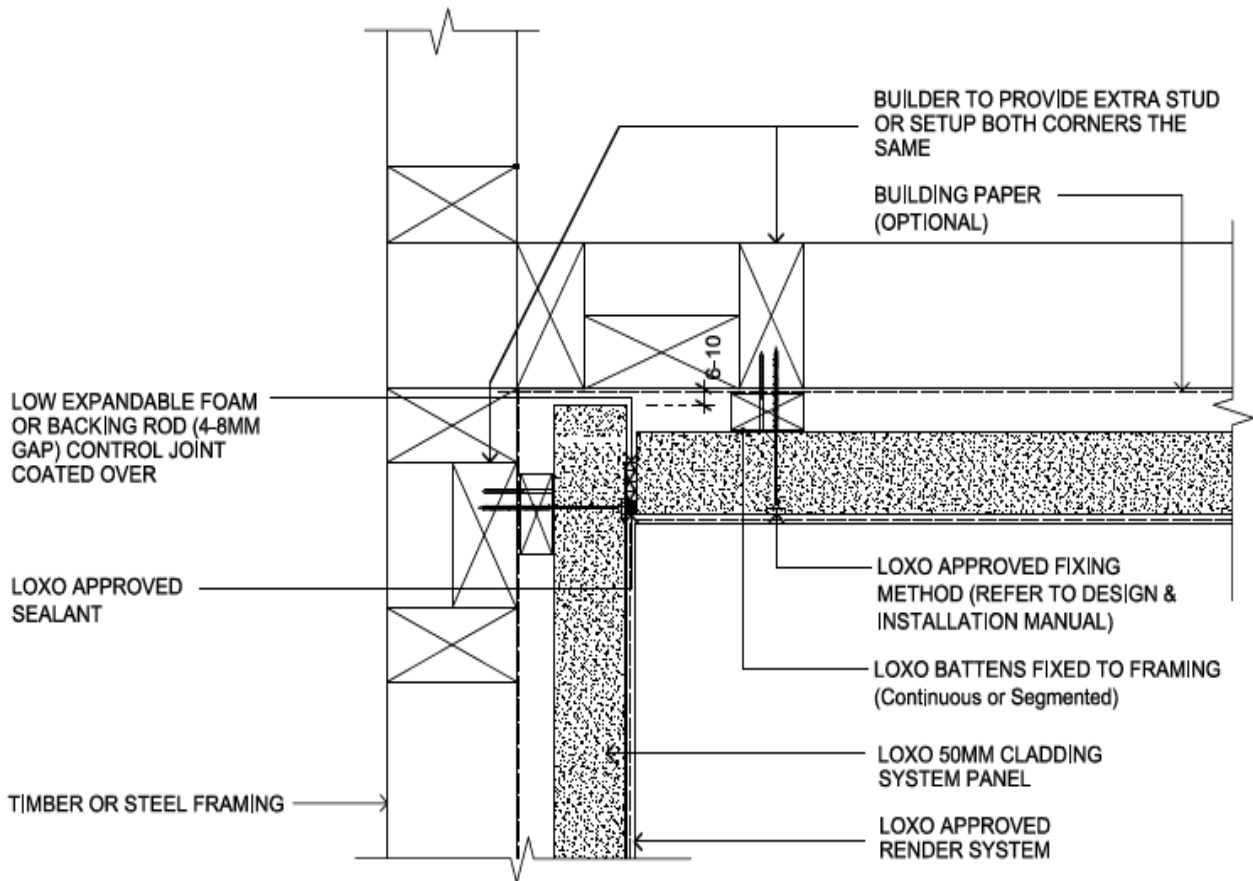

INTERNAL CORNER JUNCTION

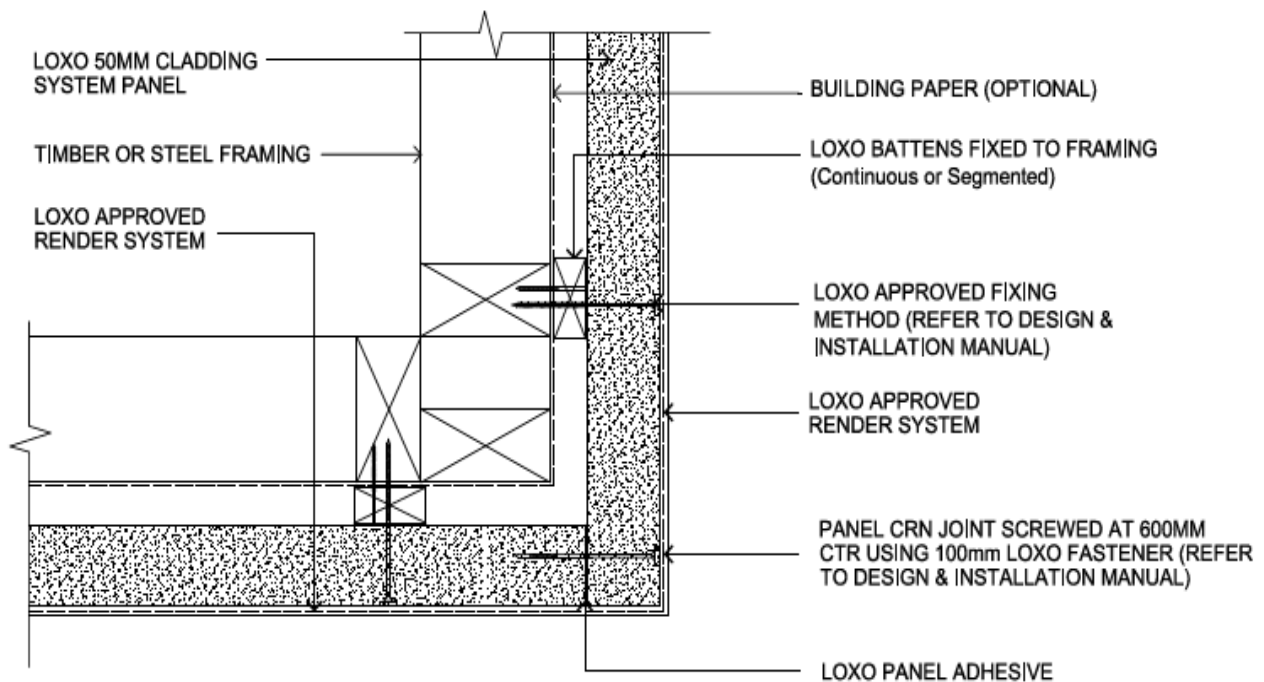

EXTERNAL CORNER JUNCTION

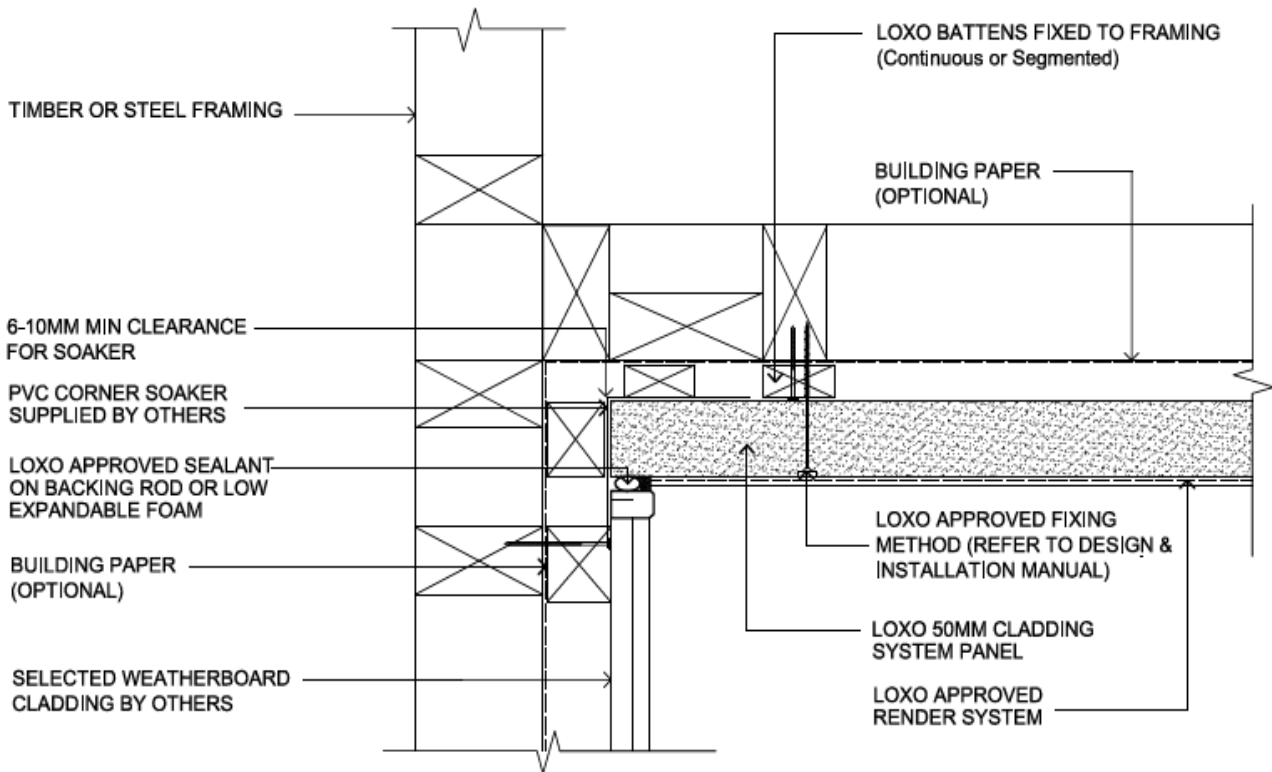

PANEL TO WEATHERBOARD INTERNAL CORNER JUNCTION

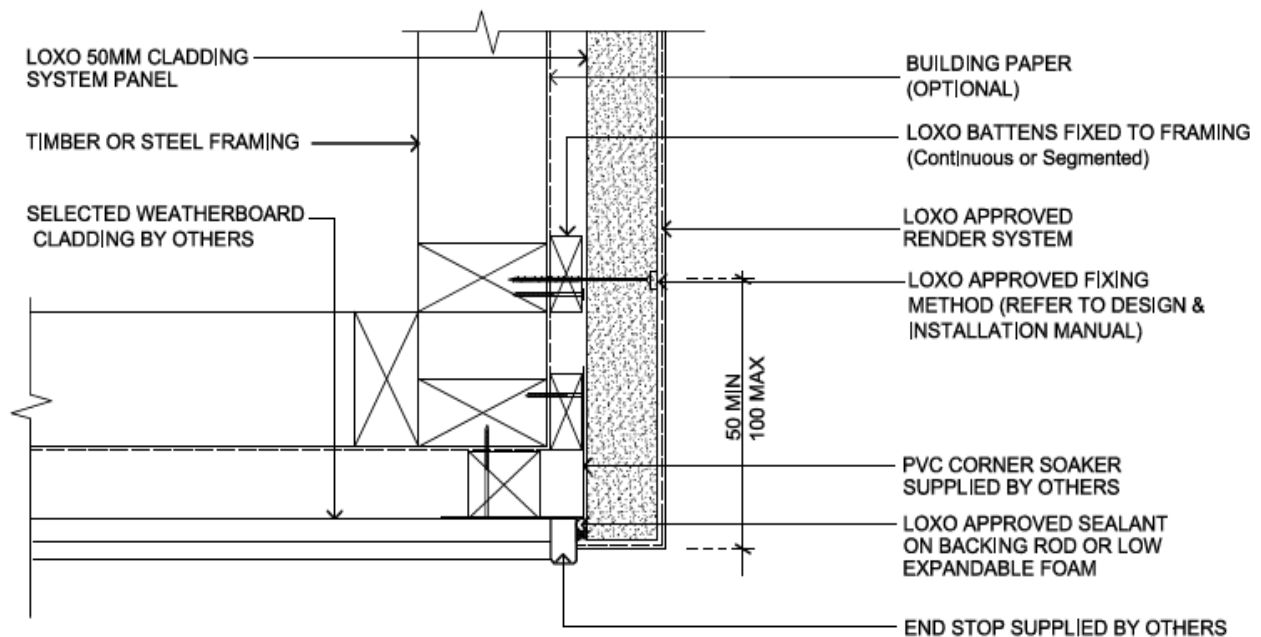

PANEL TO WEATHERBOARD EXTERNAL CORNER JUNCTION

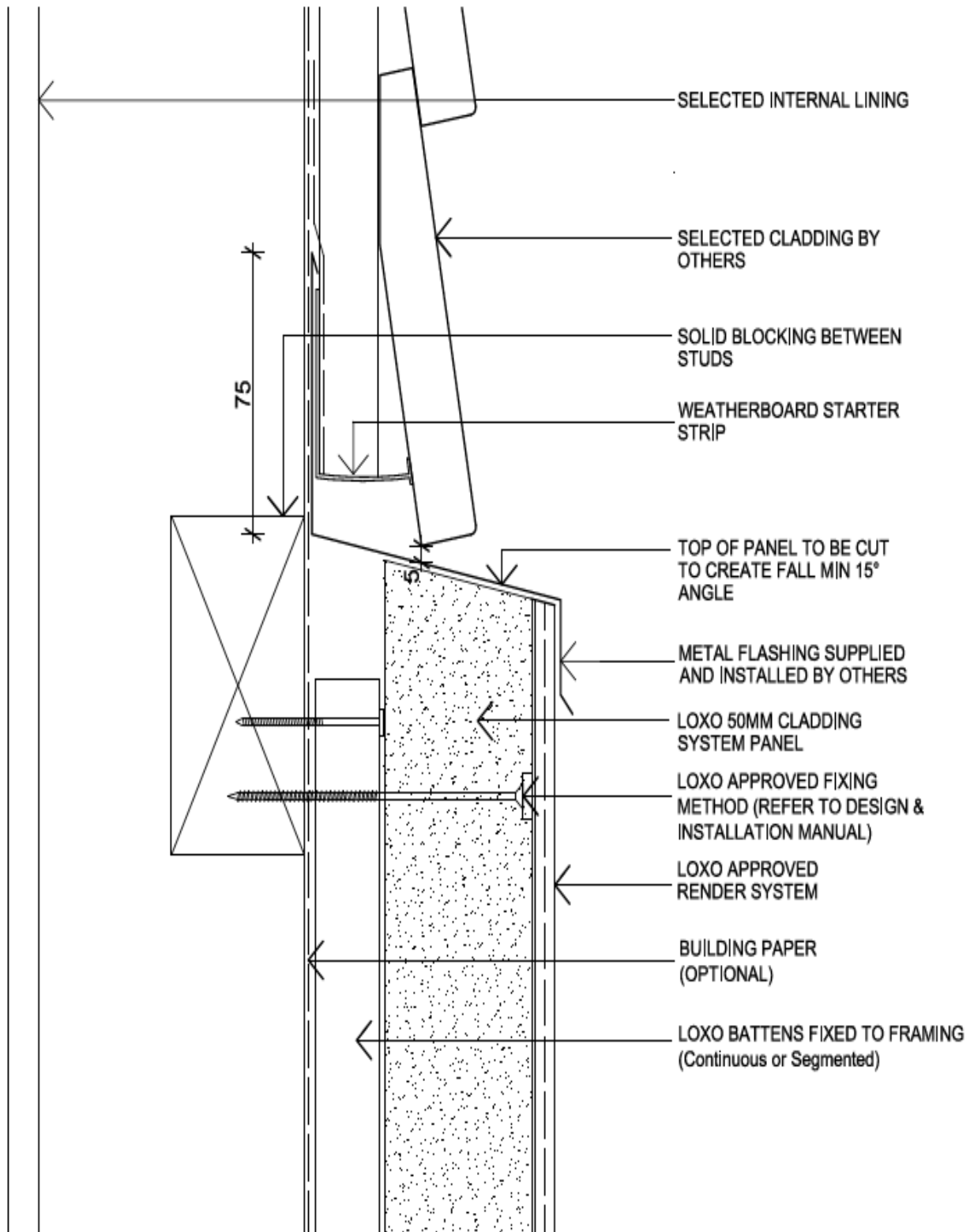

FIRST FLOOR CLADDING CHANGE DETAIL

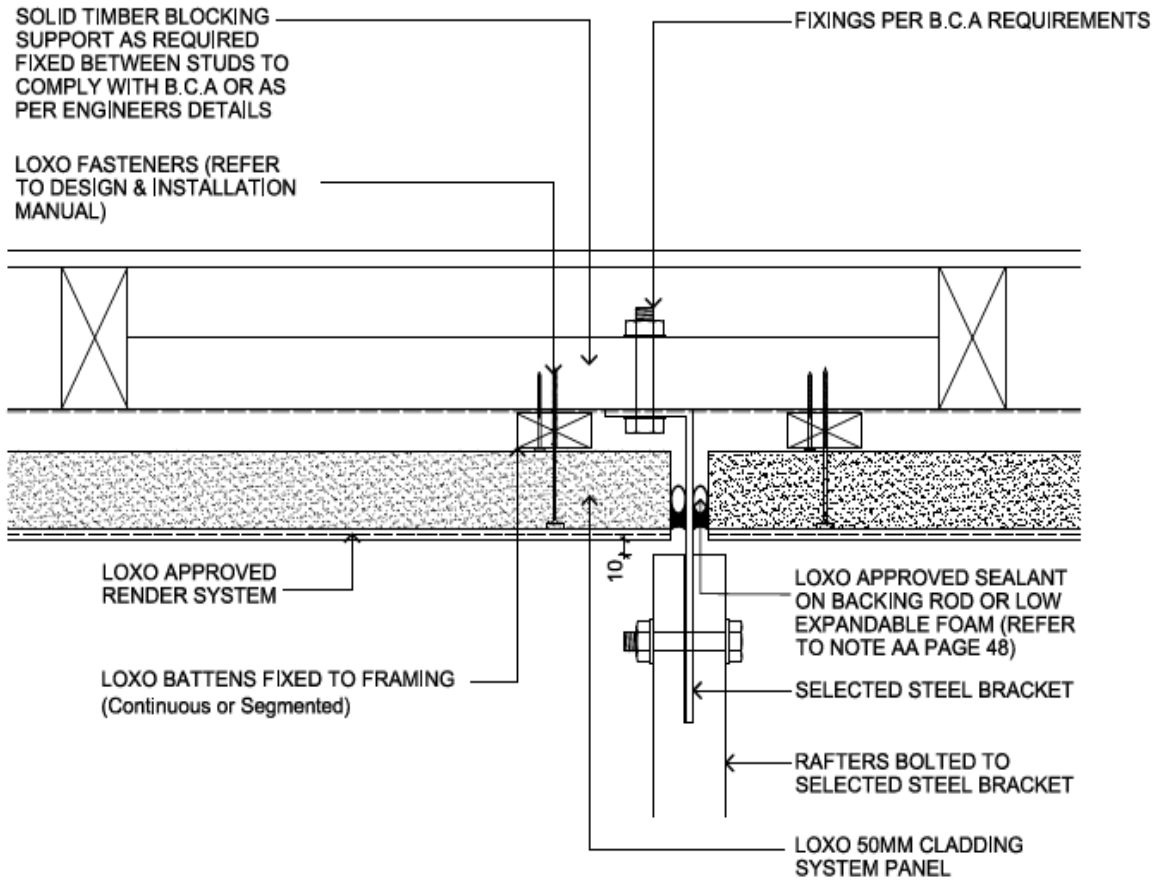

BRACKET / WALL JUNCTION PLAN

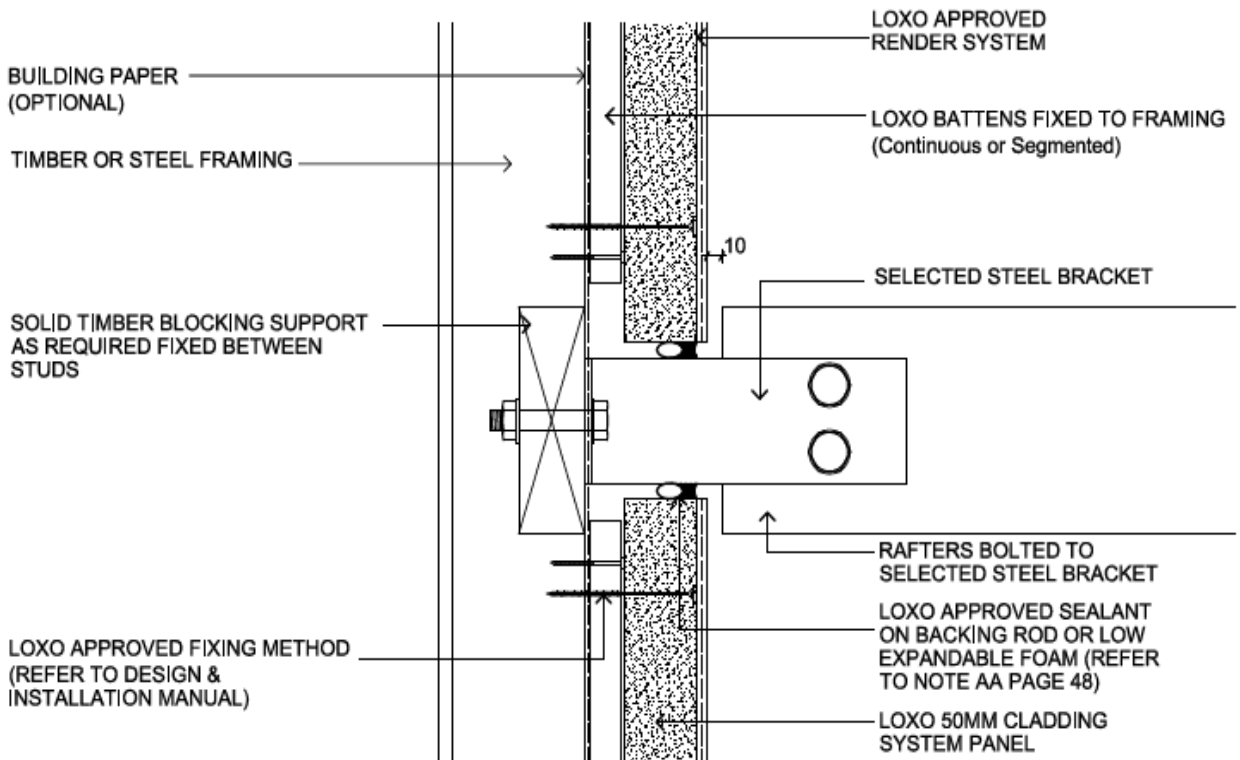

BRACKET / WALL JUNCTION SECTION

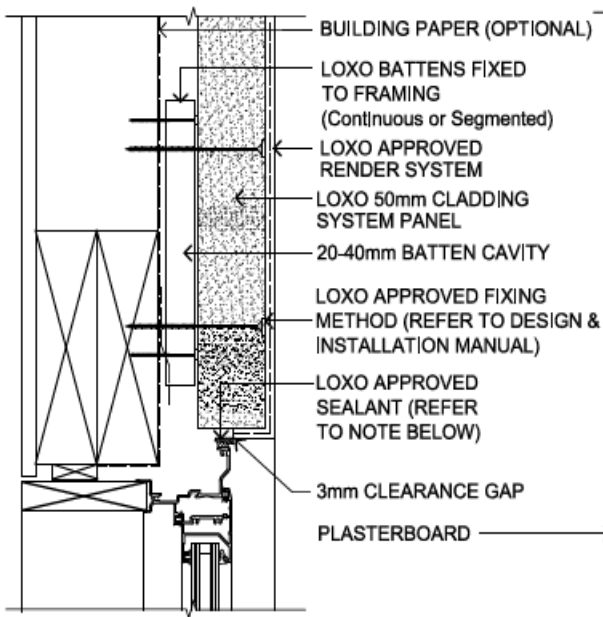

HEAD DETAIL

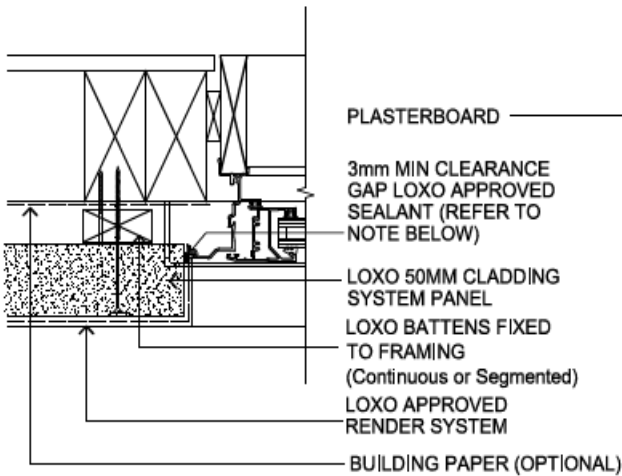
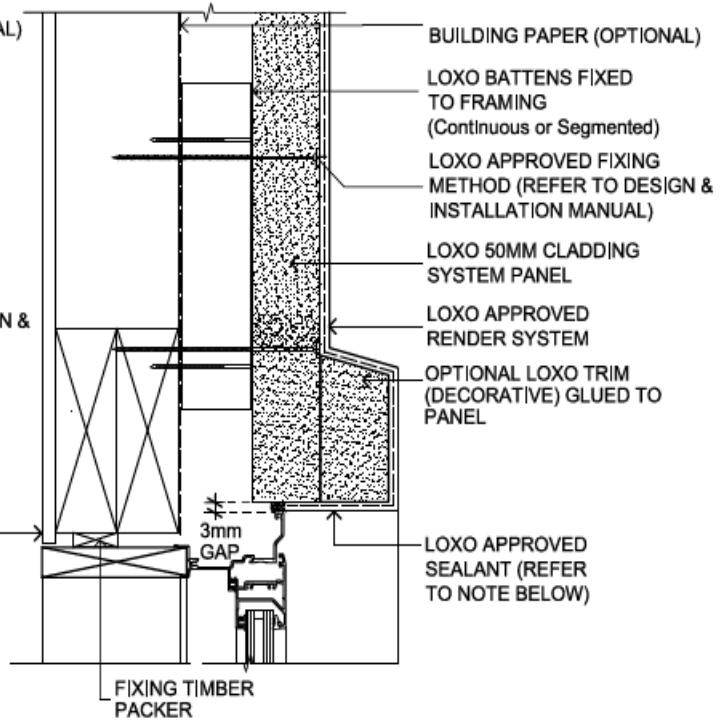

JAMB DETAIL

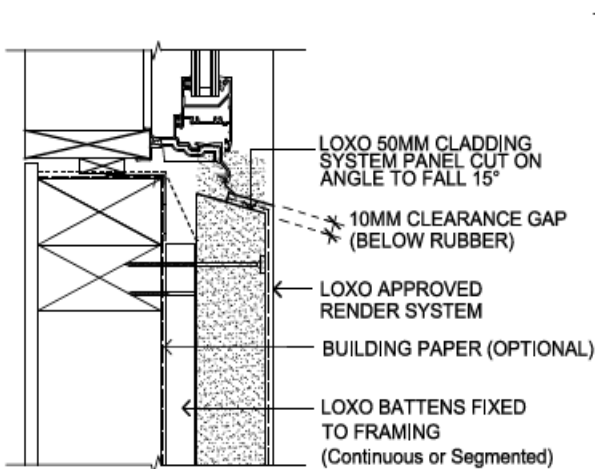
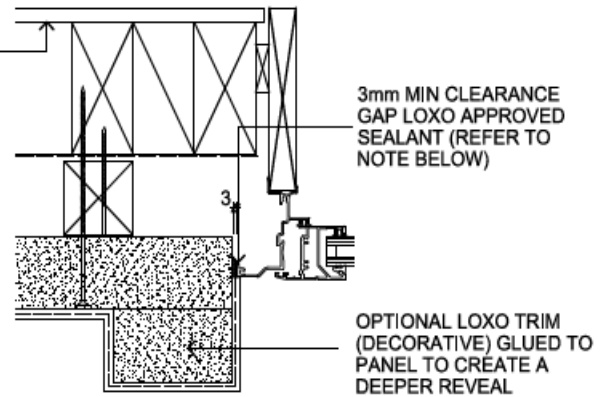

SILL DETAIL

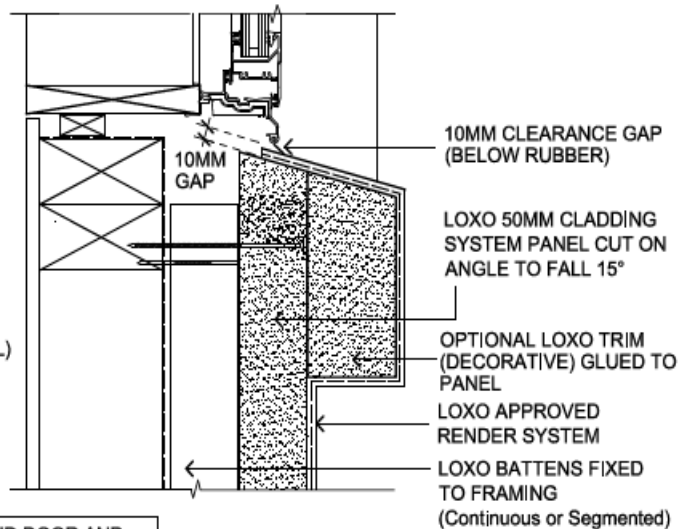

NOTE:
 SEALANT REQUIRED AROUND DOOR AND WINDOWS IN COASTAL AREAS ($\leq 1000M$ FROM WATER AND IN WIND ZONE ($\geq N4, C2$))

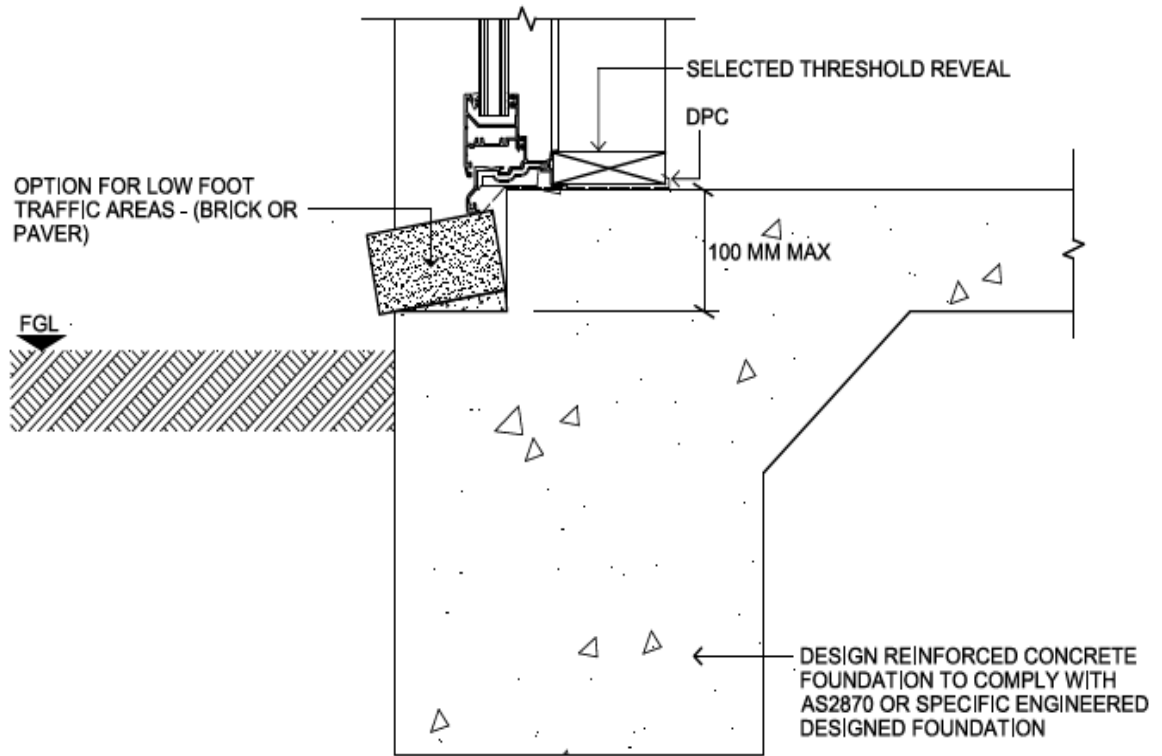

OPTION A

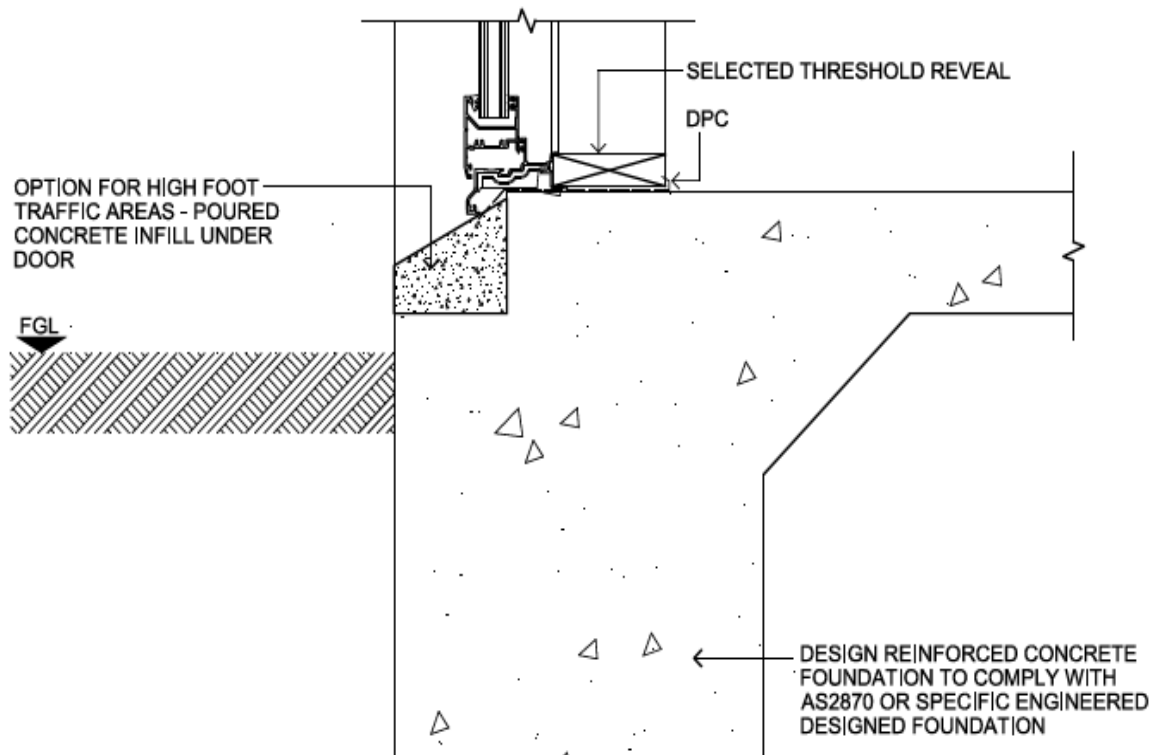

OPTION B

SOFFIT/WALL JUNCTIONS

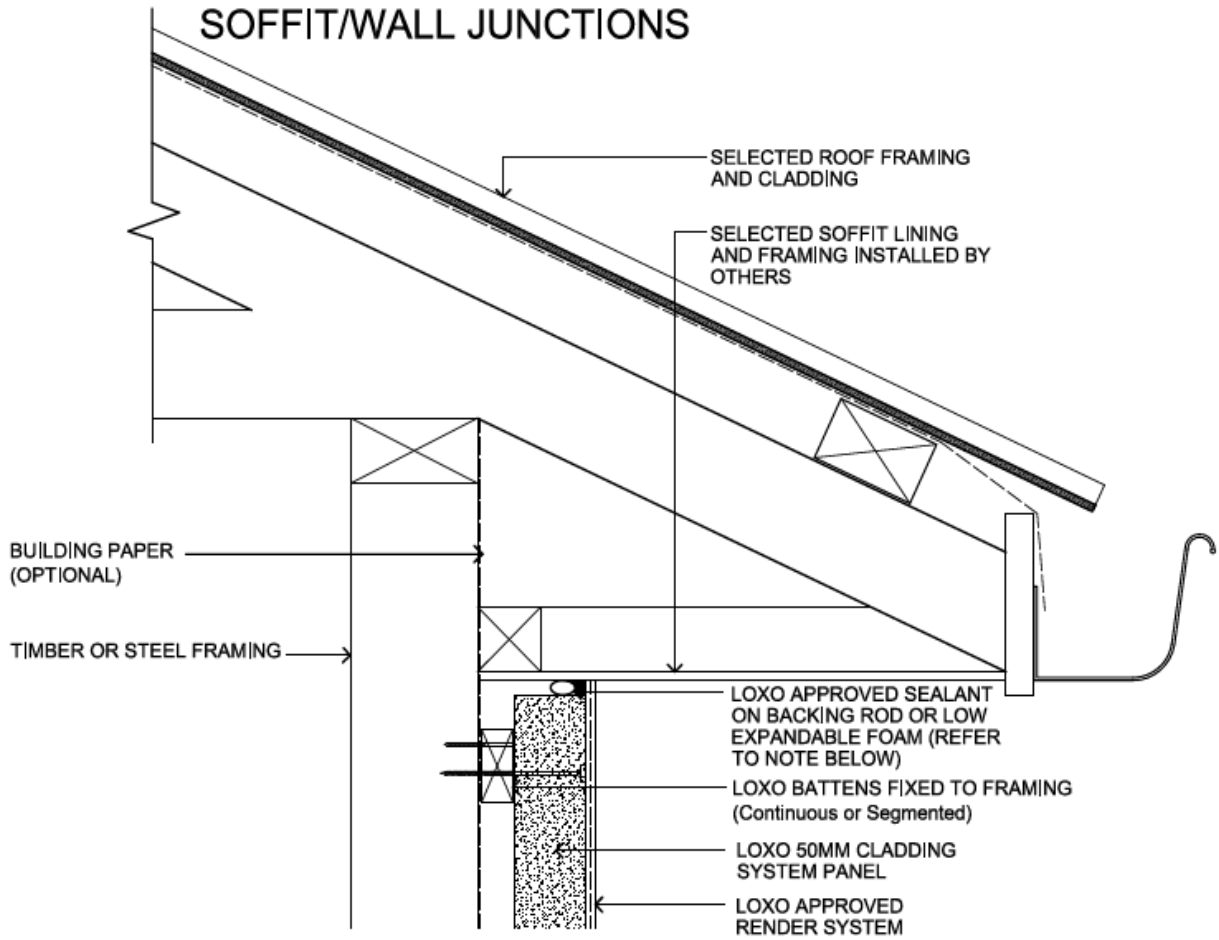

SOFFIT / WALL JUNCTION

NOTE:

SEALANT REQUIRED IN COASTAL AREAS
($\leq 1000\text{M}$ FROM WATER AND IN WIND
ZONE ($\geq \text{N4, C2}$))

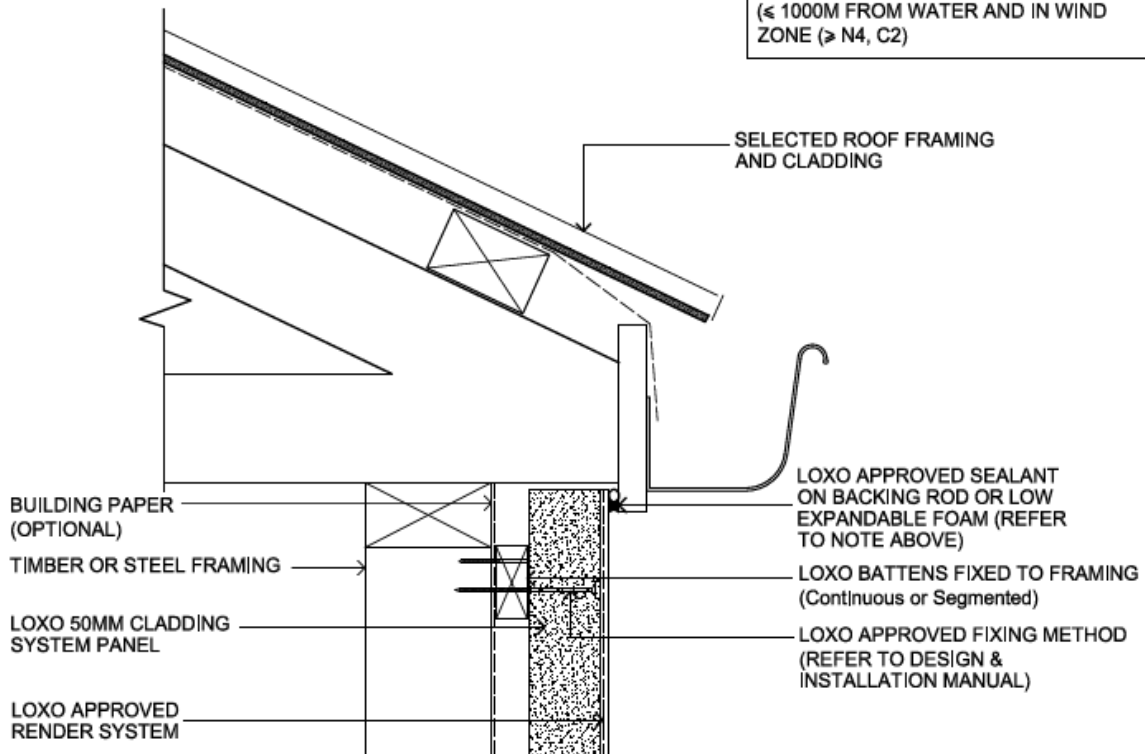

SOFFIT / WALL JUNCTION

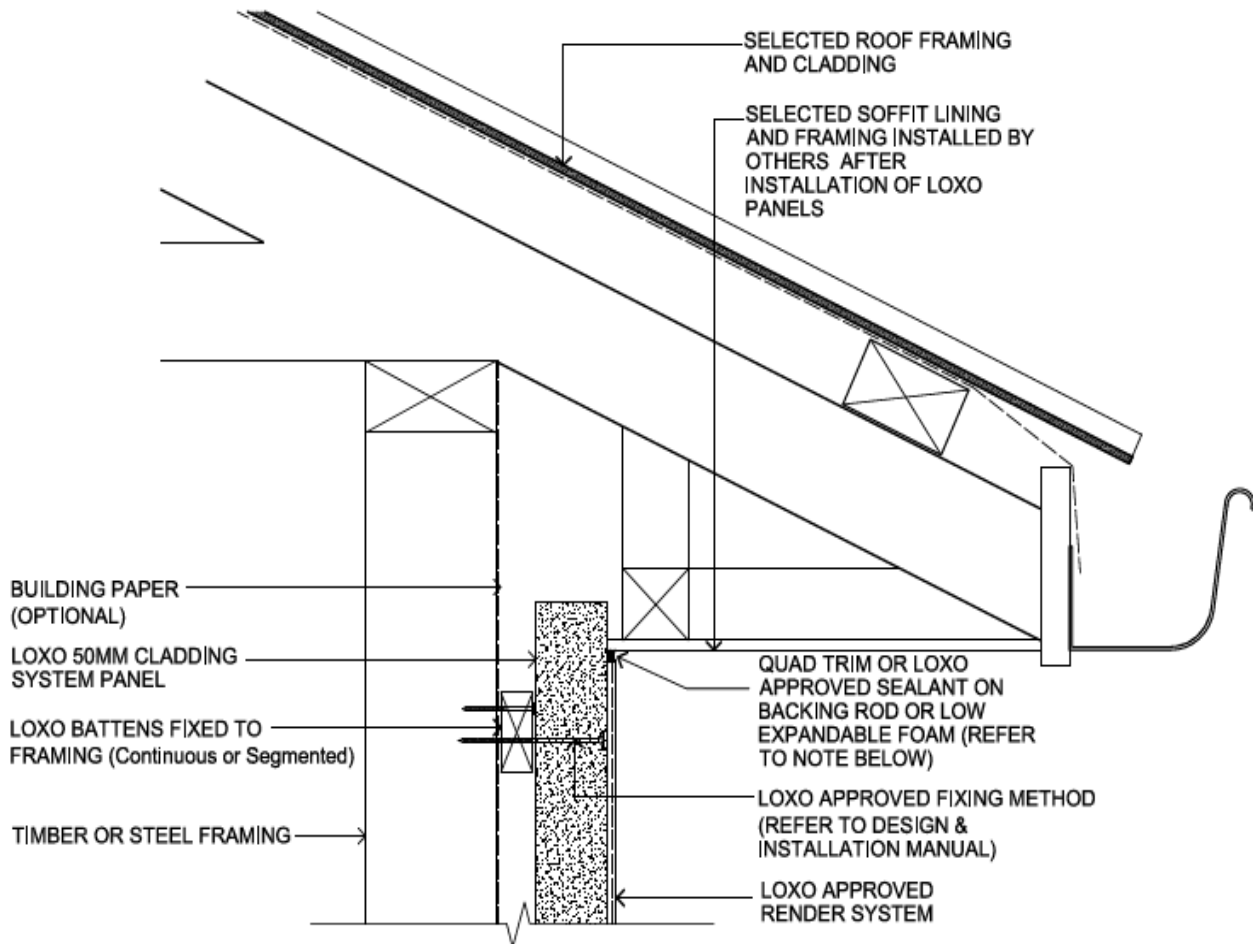

SOFFIT / WALL JUNCTION

NOTE:

SEALANT REQUIRED IN COASTAL AREAS
 (≤ 1000M FROM WATER AND IN WIND
 ZONE ≥ N4, C2)

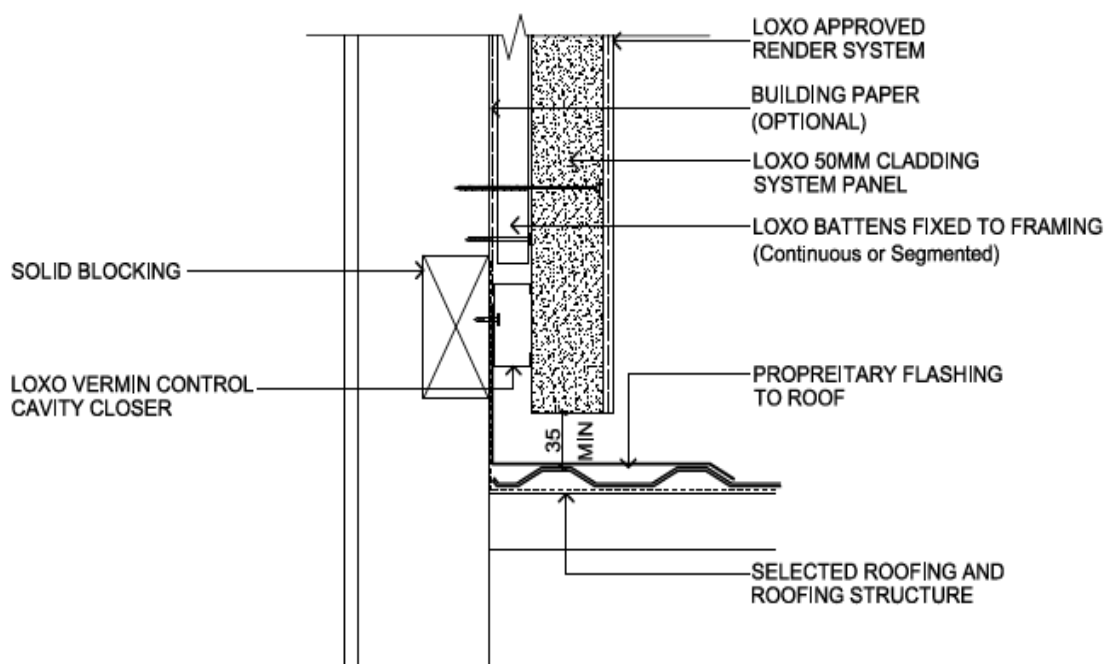

ROOF / WALL JUNCTION

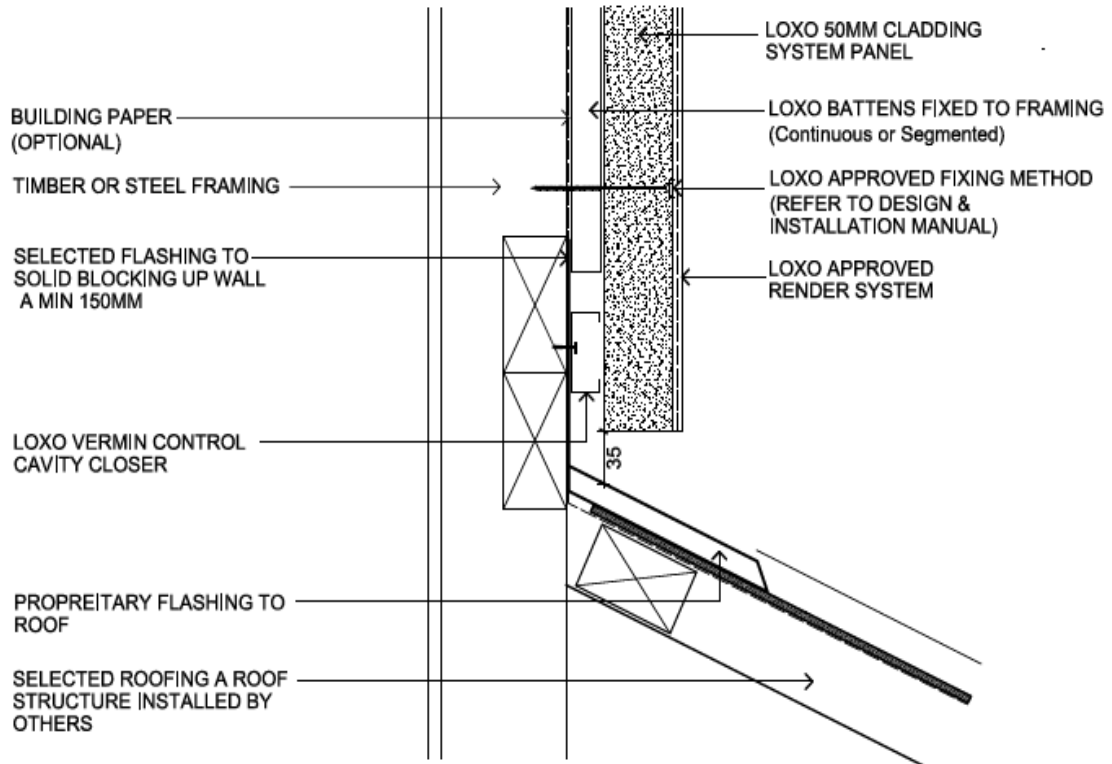

ROOF / WALL JUNCTION

NOTE:

SEALANT REQUIRED IN COASTAL AREAS
 (≤ 1000M FROM WATER AND IN WIND ZONE ≥ N4, C2)

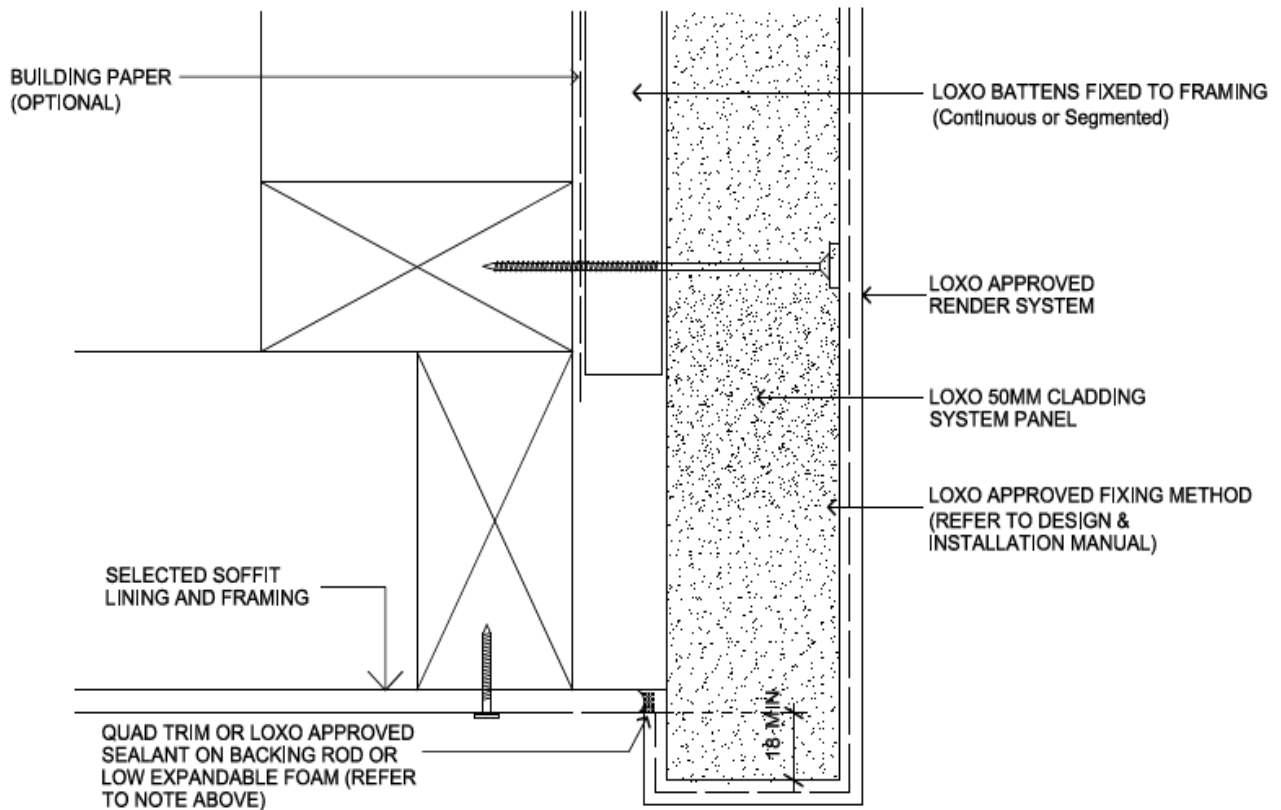

SOFFIT / WALL JUNCTION

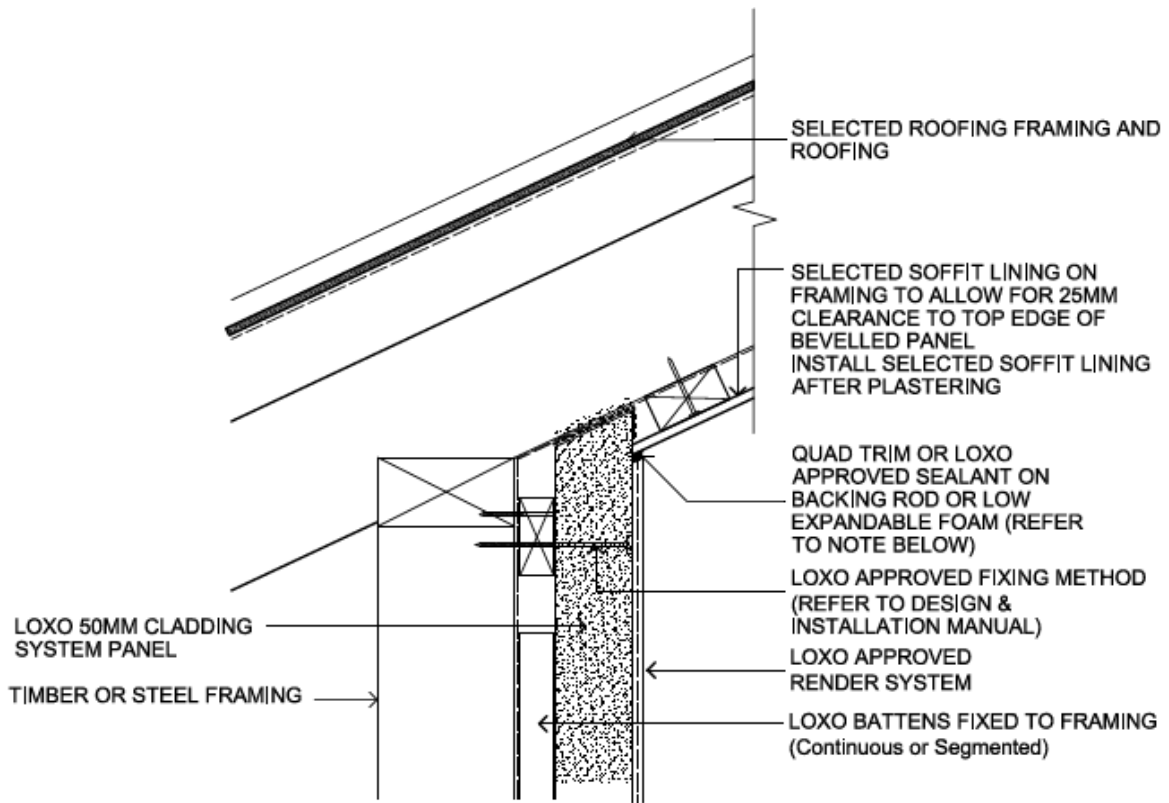

MONOPITCHED EXPOSED SOFFIT / WALL JUNCTION

NOTE:

SEALANT REQUIRED IN COASTAL AREAS
($\leq 1000\text{M}$ FROM WATER AND IN WIND ZONE $\geq \text{N4, C2}$)

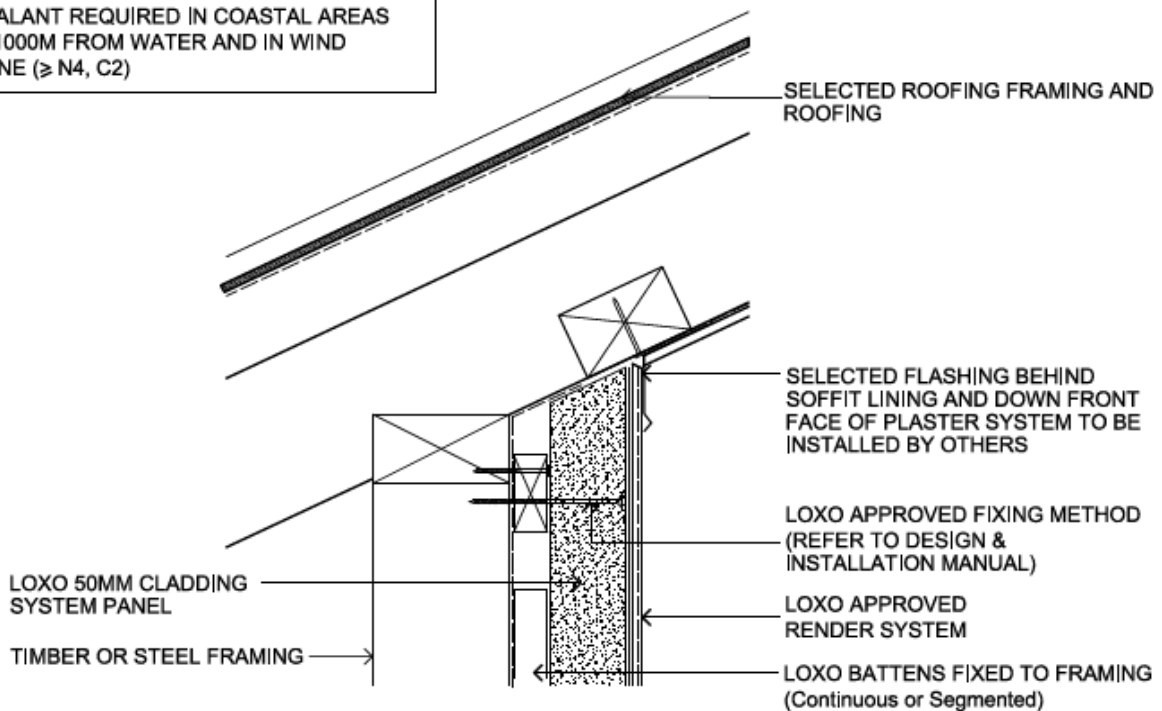

MONOPITCHED EXPOSED SOFFIT / WALL JUNCTION (Metal Flashing)

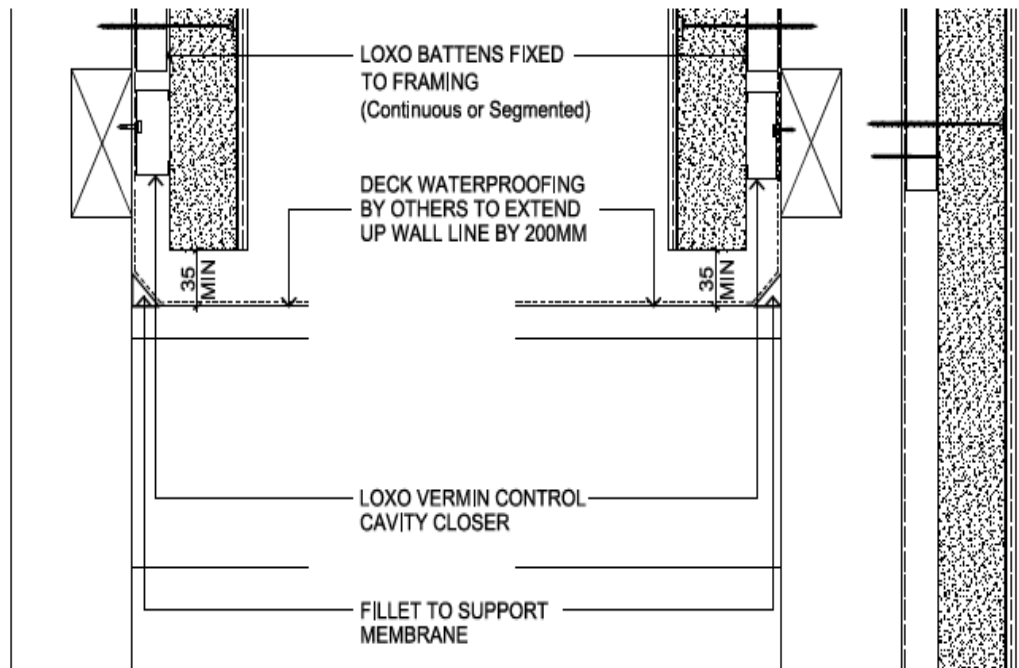
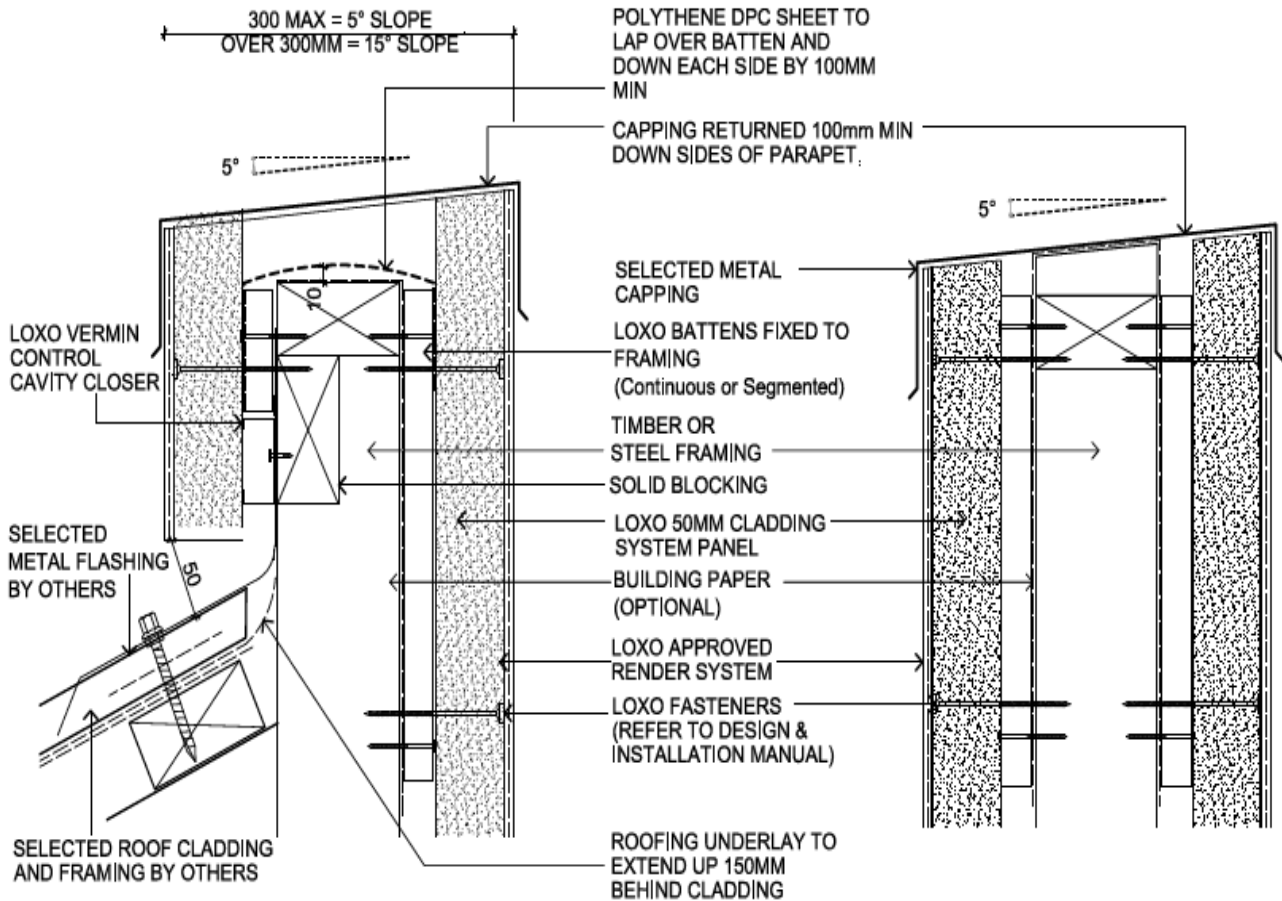

PARAPET / ROOF DETAIL - METAL FLASHING

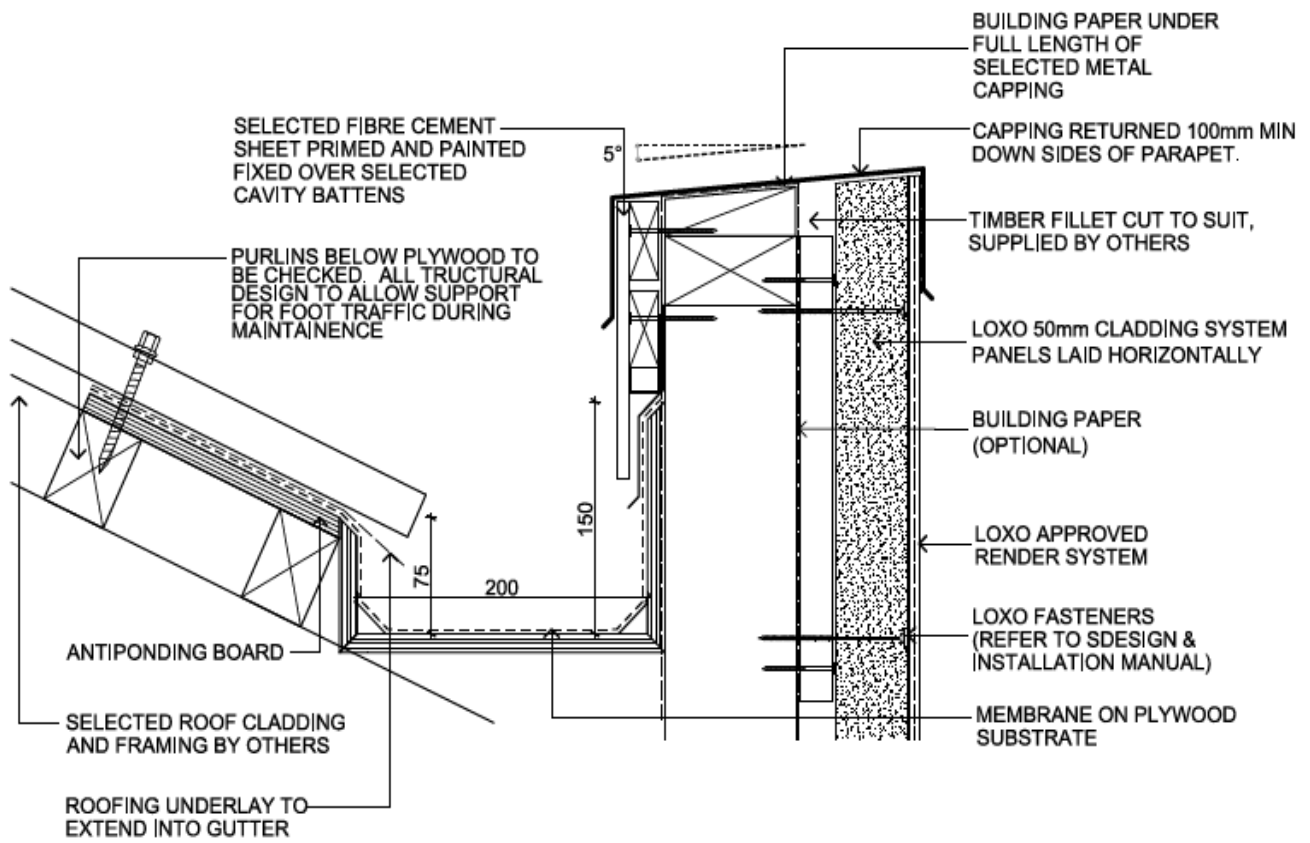

PARAPET / INTERNAL GUTTER DETAIL

NOTE:
 ALL DIMENSIONS SHOWN ARE INDICATIVE ONLY. ALL ARE SPECIFIC TO DESIGN

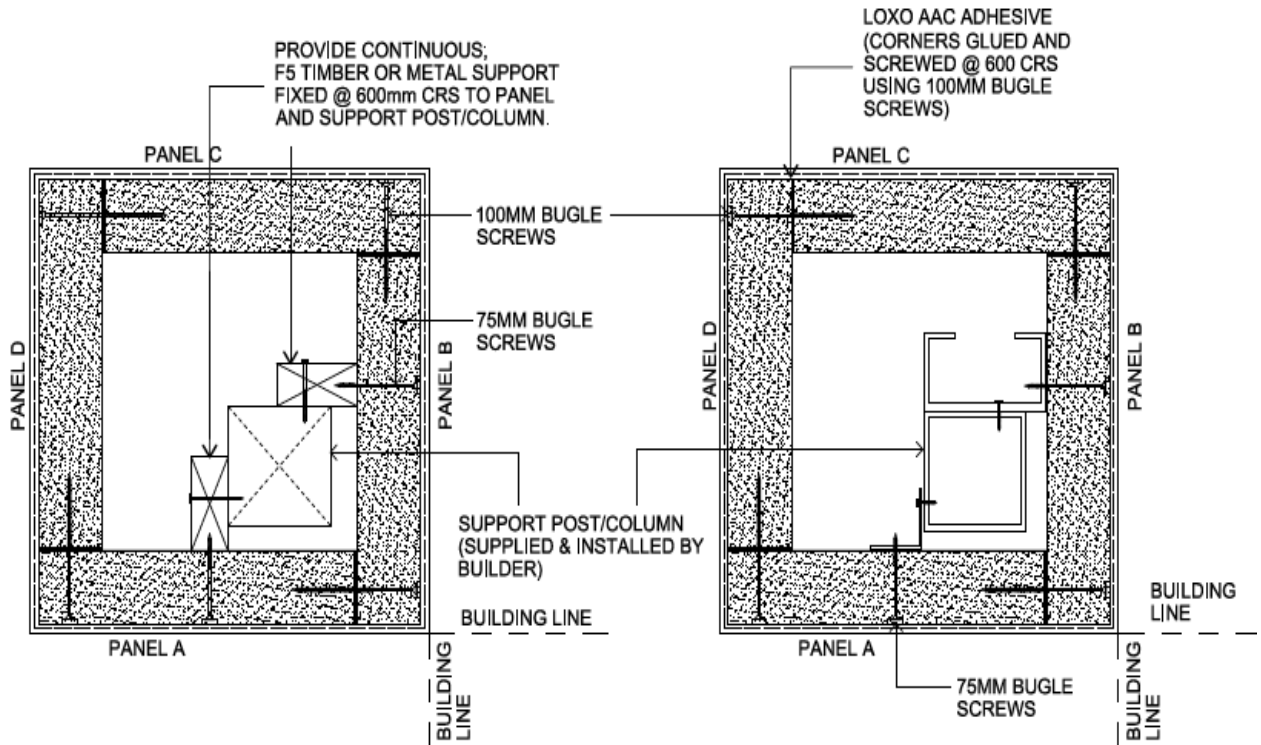

NOTE:
THIS DETAIL IS NOT SUITABLE FOR
SUSPENDED PANELS

CONSTRUCTION METHOD

- 1- FIX PANEL A TO PANEL B
- 2- ALIGN WITH BUILDING LINE IN BOTH DIRECTIONS
- 3- FIX PANEL A TO CONTINUOUS TIMBER OR METAL SUPPORT
- 4- PLUMB PANEL A AND FIX TO SUPPORT POST/COLUMN
- 5- REPEAT 3 & 4 FOR PANEL B
- 6- FIX PANEL C & D TO COMPLETE THE (AAC) LOXO COLUMN

MAXIMUM SQUARE COLUMN SIZE
650mm X 650mm

MAXIMUM RECTANGULAR COLUMN SIZE
700mm X 600mm

'X' DENOTES STAGGERED PANEL JOINT

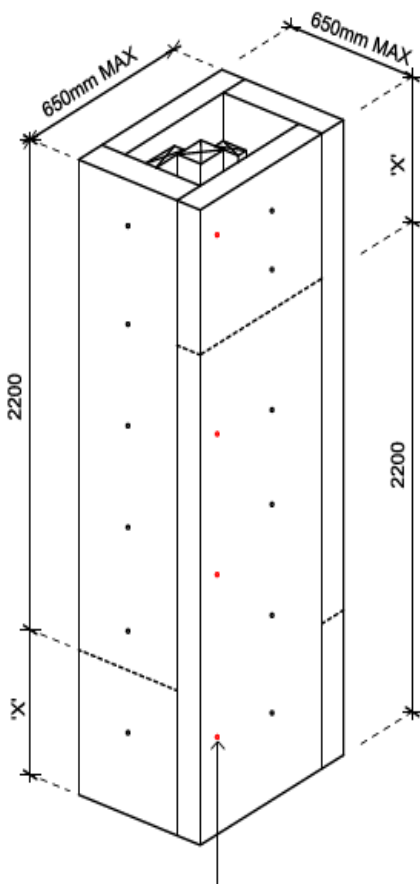

* Min. 20mm, but must also comply with termite protection requirements.

PROVIDE CONTINUOUS; F5 TIMBER OR METAL SUPPORT FIXED @ 600mm CRS TO PANEL AND SUPPORT POST/COLUMN.

LOXO APPROVED FIXING METHOD (REFER TO DESIGN & INSTALLATION MANUAL)

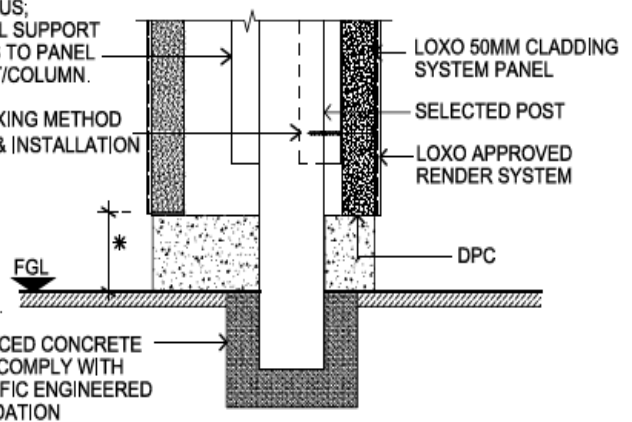

PANEL CRN JOINT GLUED & SCREWED AT 600MM CTR USING 100mm BUGLE SCREWS

LOXO POST GROUND CONNECTION DETAIL

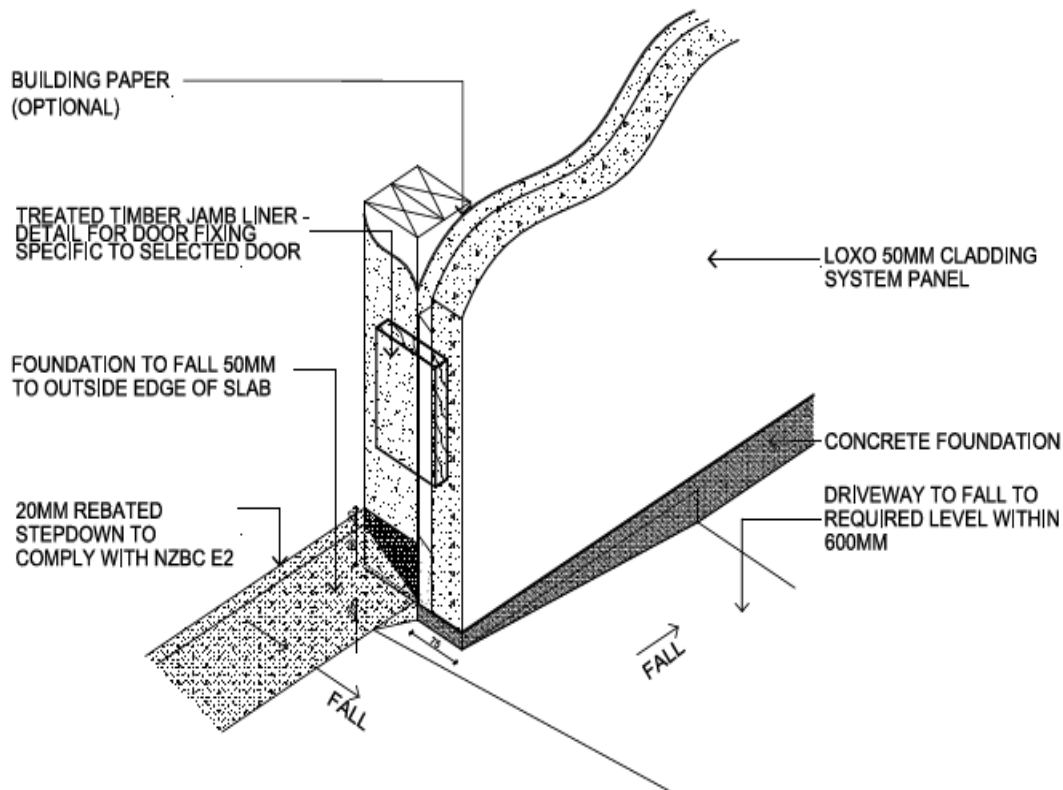

DOOR OPENING

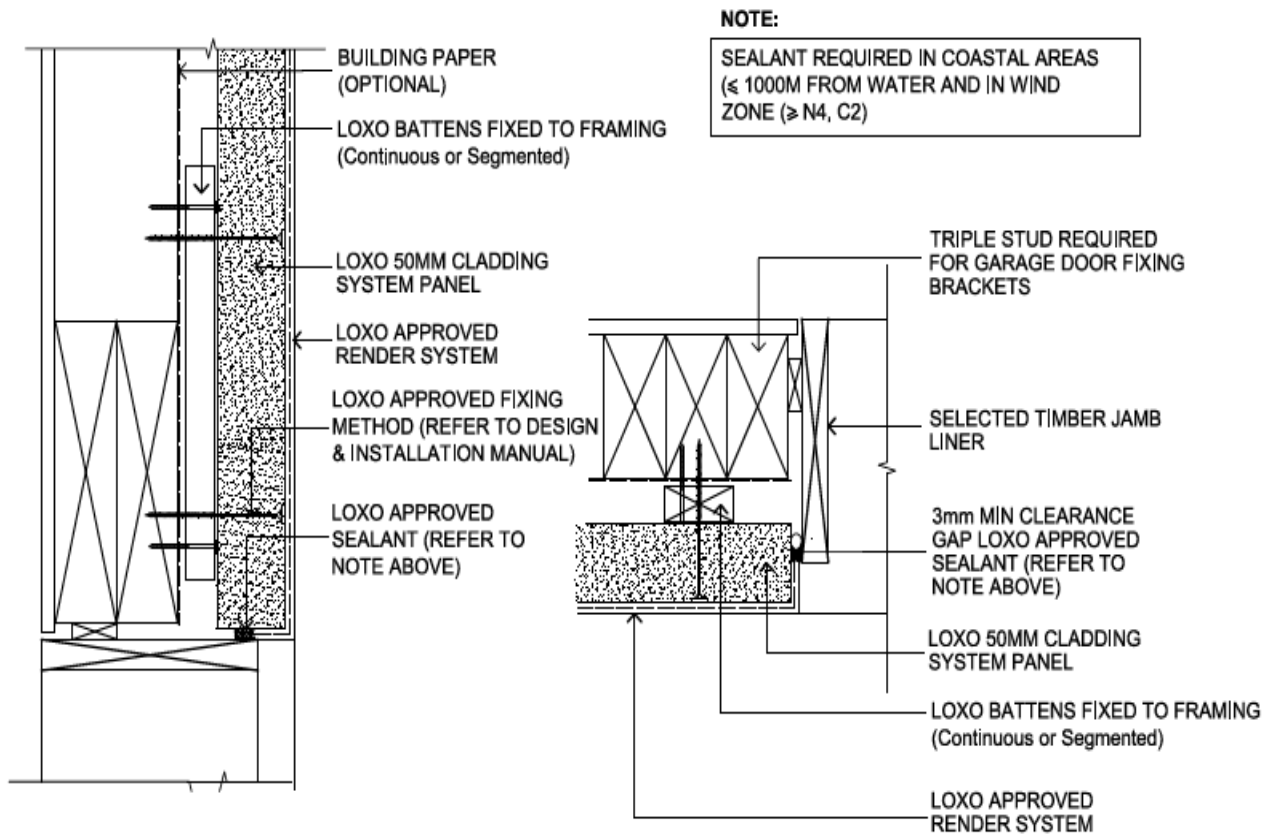

DOOR HEAD DETAIL

DOOR JAMB DETAIL

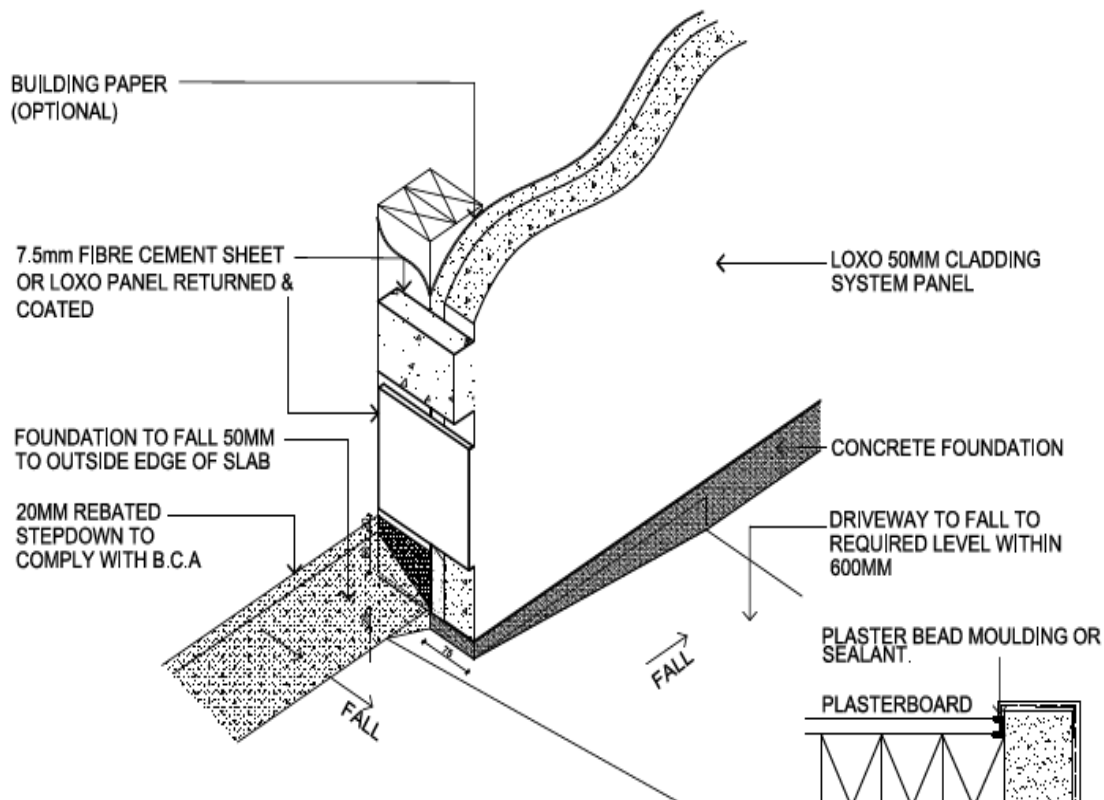

DOOR OPENING

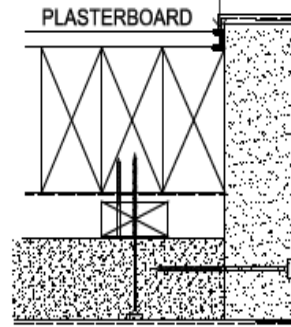

DOOR JAMB DETAIL

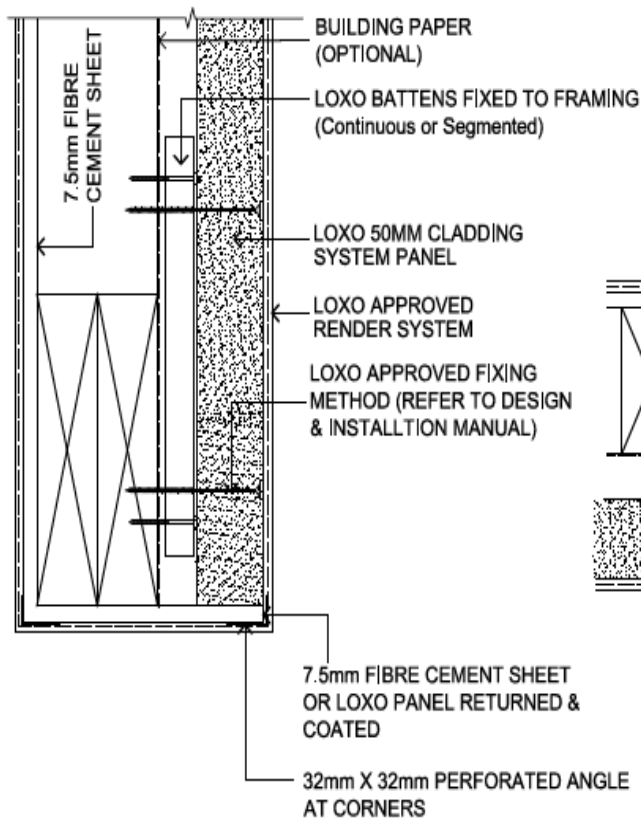

DOOR HEAD DETAIL

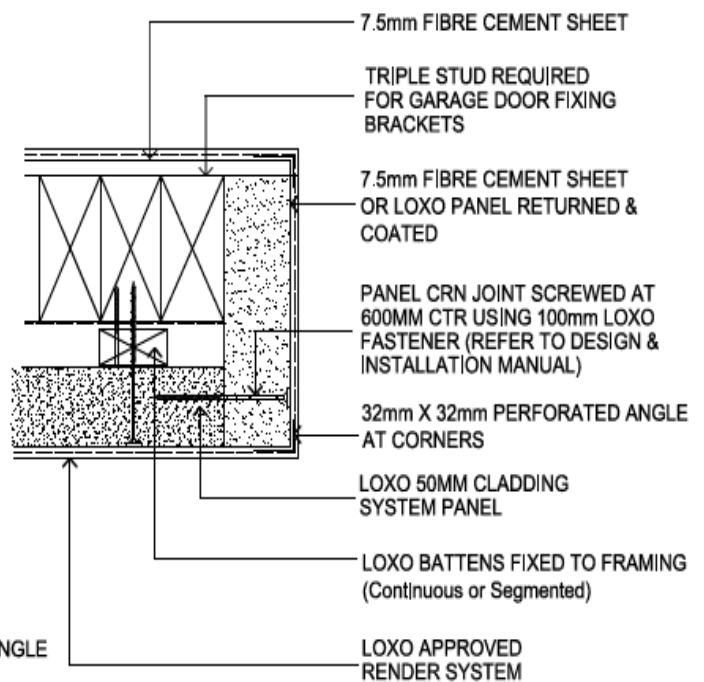

DOOR JAMB DETAIL

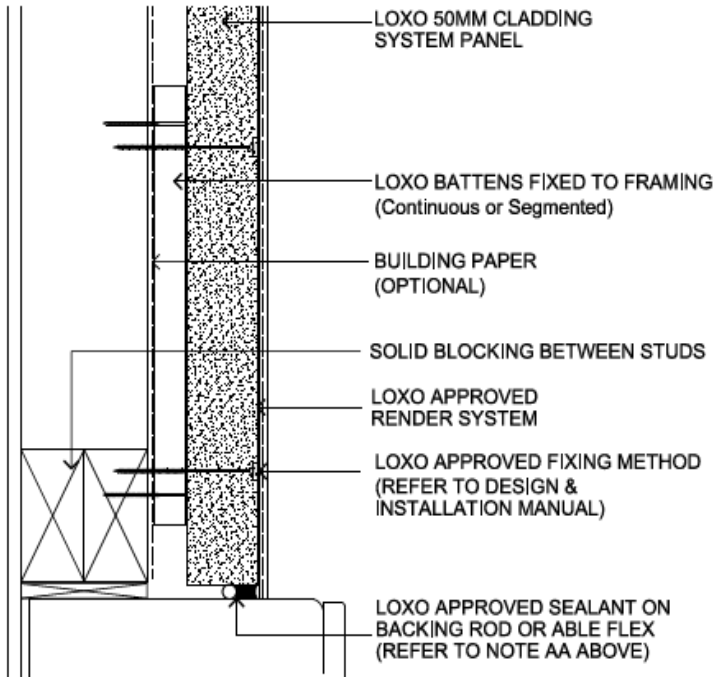

NOTE:
WHERE POSSIBLE, METERBOXES SHOULD BE LOCATED IN SHELTERED AREAS OF THE BUILDING.

NOTE AA:
ANY PENETRATION THAT IS PROUD OF THE SURFACE OF THE PANEL MUST BE SEALED.

METERBOX HEAD / JAMB / SILL DETAIL

WHERE ELECTRICAL CABLES PENETRATE EPS BATTEN, A SLEEVE OR CONDUIT SHALL BE PROVIDED AND SEALED INTO LOXO 50MM PANELS. ALL WIRES THAT PASS THROUGH A CONDUIT SHALL BE SEALED INTO POSITION INSIDE CONDUIT

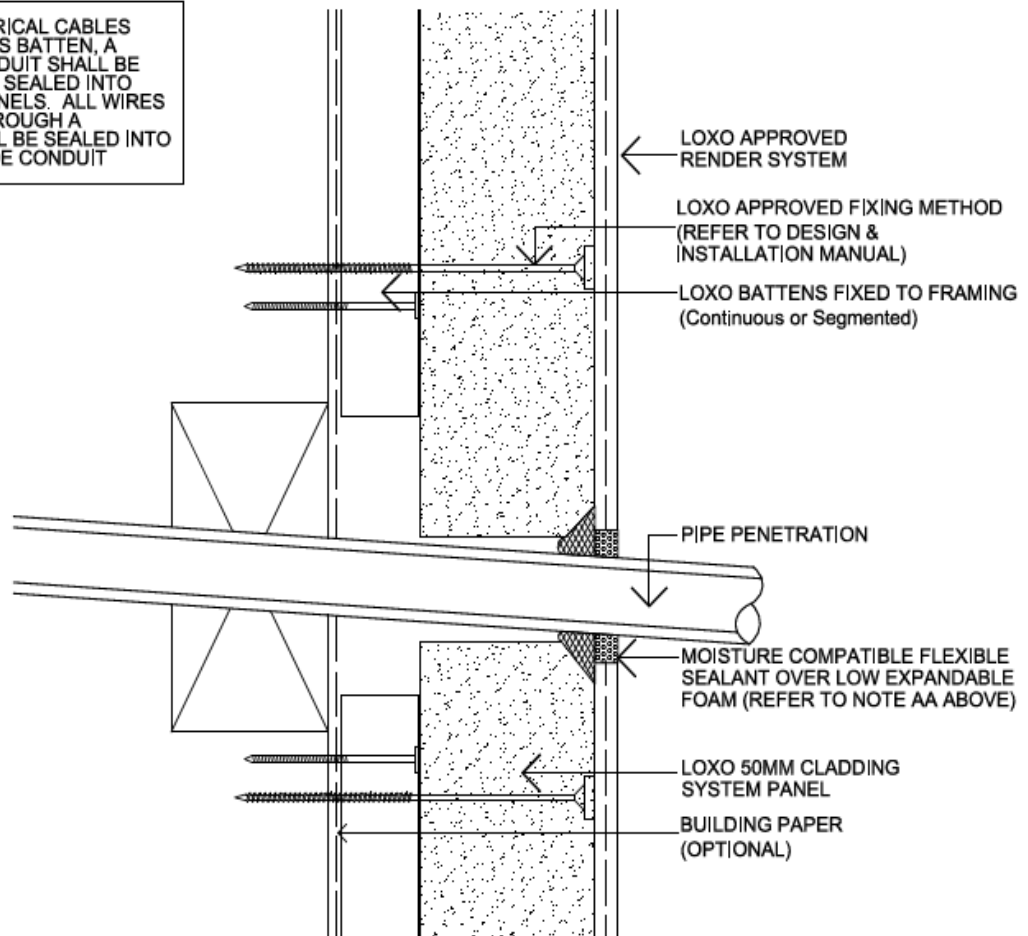

PIPE PENETRATION

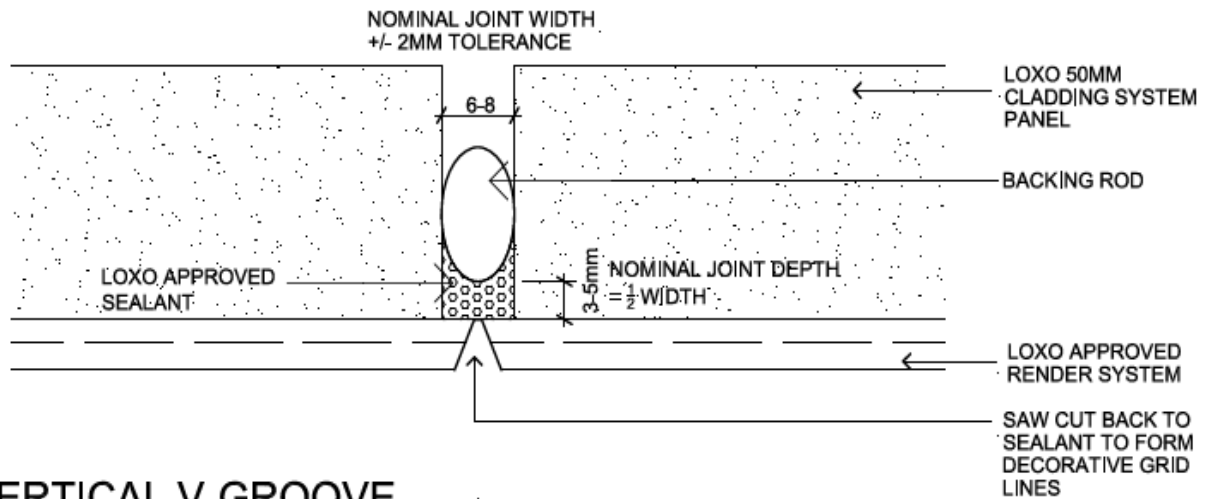

VERTICAL V-GROOVE

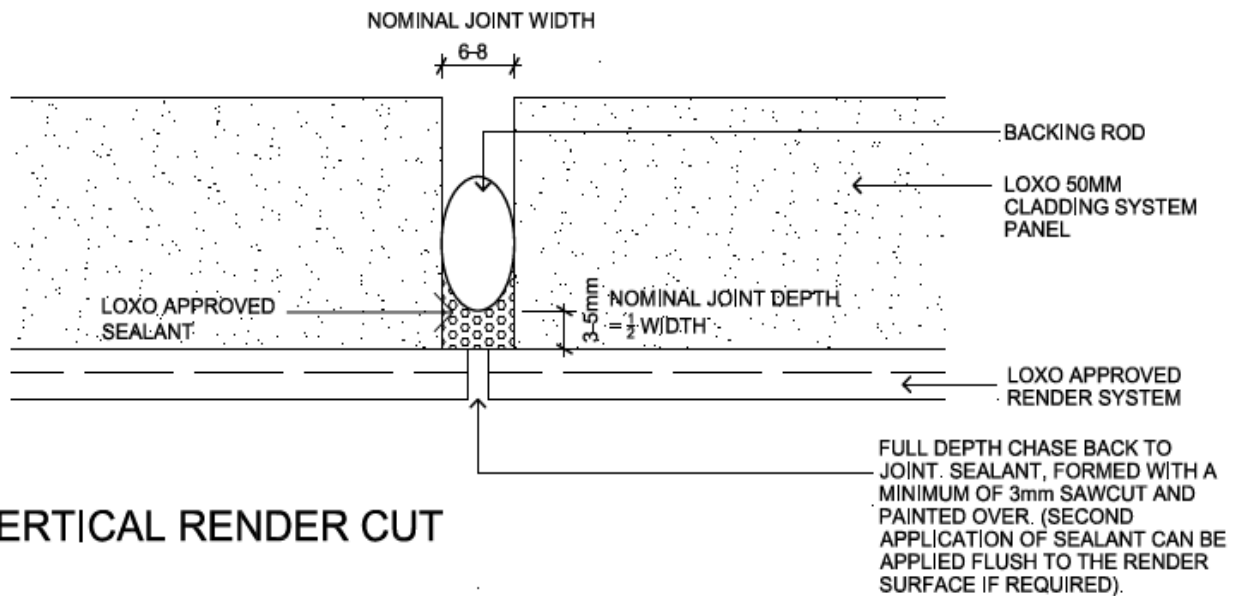

VERTICAL RENDER CUT

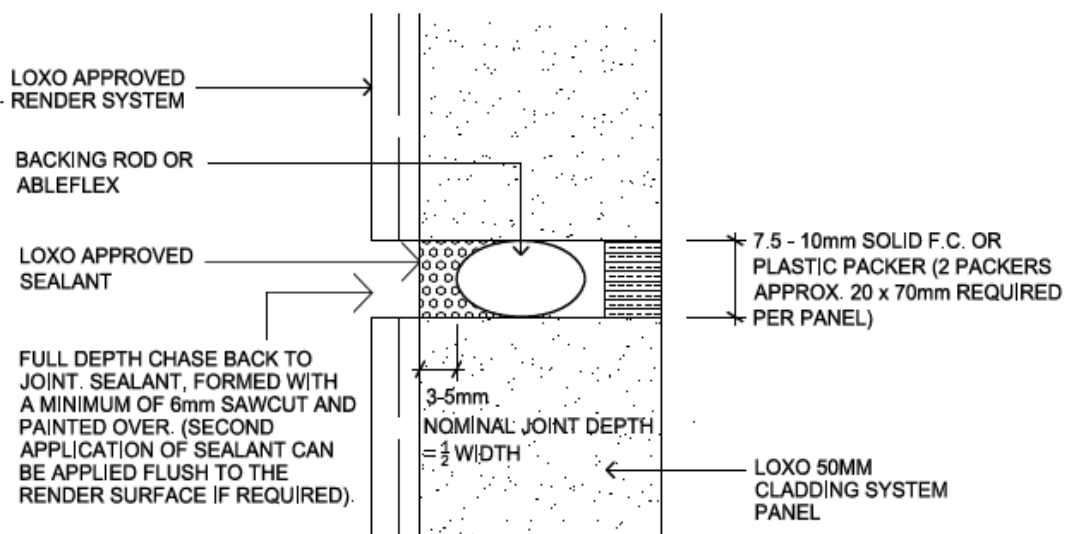

HORIZONTAL RENDER CUT

STEP 1.

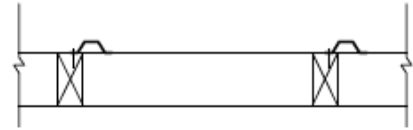
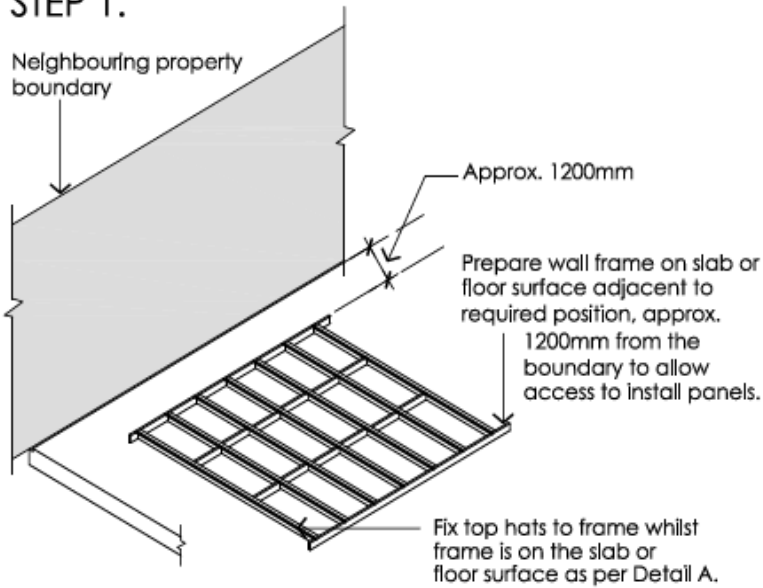

1 leg of top hats fixed at 600mm centres along studs, the second leg fixed to top plate, noggins and bottom plates.

DETAIL A

STEP 2

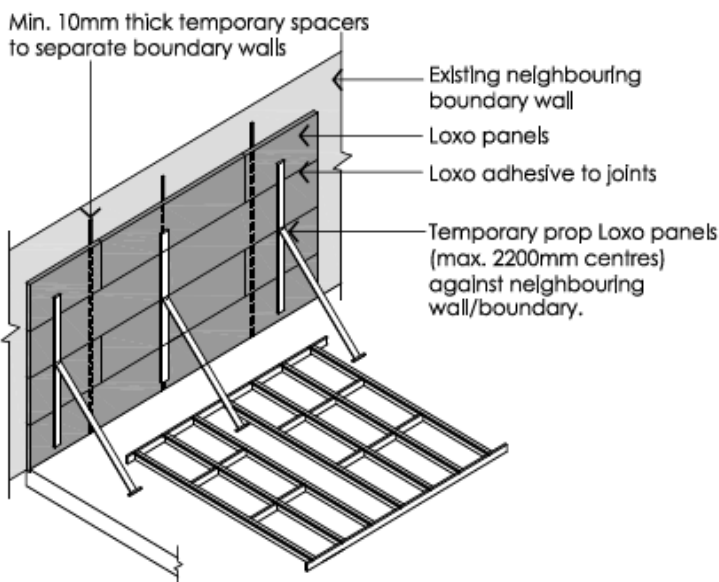

Note:
Remove or do not fix noggins in prop location until frame is stood up against Loxo panels.

STEP 3

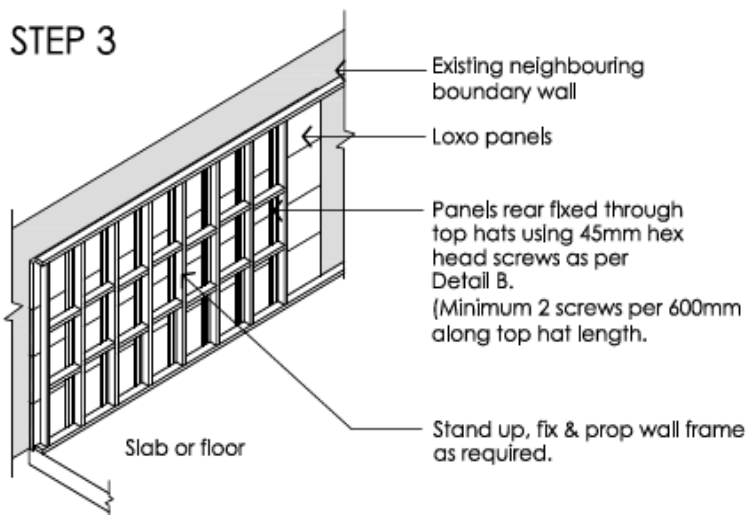

Panels rear fixed through top hats using 45mm hex head screws.

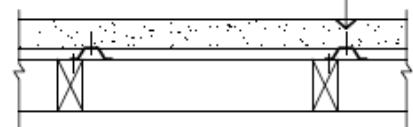

1 leg of top hats fixed at 600mm centres along studs, the second leg fixed to top plate, noggins and bottom plates.

DETAIL B

Certificate of Conformity



Certification Body:



Global-Mark Pty Ltd,
Suite 4.07,
32 Delhi Road,
North Ryde NSW
2113, Australia
Ph: +61 2 9886 0222
www.global-mark.com.au

Certificate Holder:

ONE AAC PANEL
485 Campbelltown Rd
Denham Court NSW
2565
Ph: 1300 010 222
www.oneaac.com.au

Certificate number: CM 30031 Rev 1	
THIS TO CERTIFY THAT	
ONE AAC PANEL	
<p>Type and/or use of product: ONE AAC PANELS are reinforced AAC (Autoclaved Aerated Concrete) Panels for use in all building types (BCA Vol 1 & 2), in the following applications:</p> <ol style="list-style-type: none"> 1. Fire, thermal & acoustic rated cladding for load-bearing, single leaf external timber or steel framed walls. 2. Fire, thermal & acoustic rated cladding for load-bearing, dual zero boundary external timber or steel framed walls. 3. Fire barrier with thermal & acoustic rating between timber or steel framing of separate occupancies in residential apartments. 4. Fire, thermal & acoustic rated flooring panels for timber or steel framed floor structures. 	<p>Description of product: Reinforced Autoclaved Aerated Concrete (AAC) Panels in the following sizes:</p> <ul style="list-style-type: none"> • 50mm thickness (2,200mm length x 600mm width), and • 75mm thickness (1,800mm, 2,200mm, 2,400mm, 2,700mm, 2,850mm, 3,000mm & 3,300mm lengths x 600mm width)
COMPLIES WITH THE FOLLOWING BCA PROVISIONS AND STATE OR TERRITORY VARIATION(S)	
Volume One	Volume Two
BP1.1	P2.1.1
Structural Provisions	Structural stability and resistance to actions
BP1.2	
Structural Provisions	
FP1.4	P2.2.2
Damp and Weatherproofing	Weatherproofing

Scope of certification: The CodeMark Scheme is a building product certification scheme. The rules of the Scheme are available at the ABCB website www.abcb.gov.au. This Certificate of Conformity is to confirm that the relevant requirements of the Building Code of Australia (BCA) as claimed against have been met. The responsibility for the product performance and its fitness for the intended use remain with the certificate holder. The certification is not transferrable to a manufacturer not listed on Appendix A of this certificate.

Disclaimer: The Scheme Owner, Scheme Administrator and Scheme Accreditation Body do not make any representations, warranties or guarantees, and accept no legal liability whatsoever arising from or connected to, the accuracy, reliability, currency or completeness of any material contained within this certificate; and the Scheme Owner, Scheme Administrator and Scheme Accreditation Body disclaim the extent permitted by law, all liability (including negligence) for claims of losses, expenses, damages and costs arising as a result of the use of the product(s) referred to in this certificate. The purpose of Global-Mark construction site audits is to confirm the practicability of installing the product; and to confirm the appropriateness and accuracy of installation instructions in placing the CodeMark mark on the product/system, the certificate holder makes a declaration of compliance with the certification standard(s) and confirms that the product is identical to the product certified herein. In issuing this Certificate of Approval Global-Mark has relied on the expertise of external bodies (laboratories, and technical experts).

Herve Michoux

Herve Michoux
Global-Mark Managing Director

P. Gardner

Peter Gardner
Unrestricted Building Certifier

Date of issue: 03/10/2019

Date of expiry: 24/09/2022



Certificate number: CM 30031

This certificate is only valid when reproduced in its entirety.

Page 1 of 7

Deemed-to-Satisfy Provision(s):	A5.4	Fire Resistance of Building Elements				
	B1.4 (b) (ii)	Structural Resistance		3.5.4.0	Wall Cladding	
	C1.9	Non-Combustible Material				
	Specification C1.1	Fire-Resisting Construction		3.7.2.4	Fire Safety – Construction of External Walls	
				3.7.3.2	Fire Protection of Separating Walls	
				3.7.3.5	Fire Protection – Horizontal Projections	
				3.7.4.3	Fire Protection of Separating Floors	
	F1.9	Damp-proofing				
	F5.2	Determination of airborne sound insulation ratings		3.8.6.3	Determination of airborne sound insulation ratings	
	F5.3	Determination of impact sound insulation ratings				
	F5.4	Sound Insulation Rating of Floors				
	F5.5	Sound Insulation Rating of Walls		3.8.6.2	Sound Insulation Requirements	
				3.8.6.4	Construction of Sound Insulated Walls	
	G5.2	Construction in bushfire prone areas		3.10.5.0 (c)	Construction in bushfire prone areas	
	J1.5	Building Fabric		3.12.1.4	Building Fabric – External Walls	
State or territory variation(s):	NT Part F5	Sound Transmission & Insulation		NT Part 3.8.6	Sound Insulation	
	NSW G5.2	Construction in Bushfire Prone Areas		NSW 3.10.5.0 (c)	Construction in Bushfire Prone Areas	
				QLD 3.10.5.0 (c)	Construction in Bushfire Prone Areas	
	NSW J(A)1	Building Fabric (Class 2 & 4 only)		NSW 3.12.1	Building Fabric thermal insulation	
	NSW J(B)1	Energy efficiency (Class 3, 5, 6, 7, 8 & 9)				
	NT Section J	Replaced by BCA2009 Section J		NT Part 3.12	Replaced by BCA2009 Part 3.12	
	QLD Section J	Replaced by BCA2009 Section J (Class 2 only)				

SUBJECT TO THE FOLLOWING LIMITATIONS AND CONDITIONS AND THE PRODUCT TECHNICAL DATA IN APPENDIX A AND EVALUATION STATEMENTS IN APPENDIX B

Limitations and conditions:	Building classification/s:
<p>Vol 1 – BP1.1 & Vol 2 – P2.1.1 The wall system as described has maximum design wind load limits documented within the relevant Design & Installation Guides. Wind load limits, construction detail and fixing must follow the relevant details contained within the engineering detail sections of the relevant Design & Installation Manual.</p>	<p>1, 2, 3, 4, 5, 6, 7, 8, 9 & 10</p>
<p>Vol 1 – BP1.1 (b) (vi) and (ix) & Vol 2 – P2.1.1 (b) (v) (vi) and (ix) Snow, liquid pressure and earth pressure actions are excluded.</p>	<p>1, 2, 3, 4, 5, 6, 7, 8, 9 & 10</p>
<p>Vol 1 – BP1.4 & Vol 2 – P2.1.2 Compliance for flood hazard areas is excluded.</p>	<p>1, 2, 3, 4, 5, 6, 7, 8, 9 & 10</p>
<p>Vol1 – C1.9 Non-combustibility relates to AAC material only.</p>	<p>2, 3, 4, 5, 6, 7, 8 & 9</p>
<p>Vol 1 – Spec C1.1 & Vol 2 – 3.7.2.4 Vol 2 – 3.7.3.2 Vol 2 – 3.7.3.5 Vol 2 – 3.7.4.3 Refer to the relevant construction options, details & conditions, included in the relevant ONE AAC Design & Installation Manuals.</p> <ul style="list-style-type: none"> • External wall FRLs of up to 120/120/90 or 120/120/120 are achievable (refer construction options). • Floor FRLs of up to 90/90/90 or 120/120/120 are achievable (refer construction options). • Intertency wall FRLs of 60/60/60, 90/90/90 or 120/120/120 are achievable (refer construction options). • Dual Zero Boundary wall FRLs of 60/60/60 apply. 	<p>1, 2, 3, 4, 5, 6, 7, 8, 9 & 10</p>
<p>Vol 1 – G5.2 & Vol 2 – 3.10.5.0 (c) Construction in Bushfire Prone Areas, up to BAL FZ permitted when constructed in accordance with AS3959.</p>	<p>1, 2, 3 & 10</p>
<p>Vol 1 – J1.5 & Vol 2 – 3.12.1.4 The wall system contributes towards the Total wall system U or R value, which is to be determined in accordance with Vol 1 - J1.5 & Vol 2 - 3.12.1.4. Insulation shall be included within the wall system, as outlined in the relevant Design & Installation Manual & according to project specifications.</p>	<p>1, 2, 3, 4, 5, 6, 7, 8, 9 & 10</p>

Vol 1 – NSW G5.2 Construction in Bushfire Prone Areas, up to BAL FZ permitted when constructed in accordance with AS3959.	& Vol 2 – NSW 3.10.5.0 (c)	1, 2, 3 & 10
Vol 1 – QLD G5.1 Construction in Bushfire Prone Areas, up to BAL FZ permitted when constructed in accordance with AS3959. This applies to buildings located in a designated Bushfire Prone area but does not apply when the classified vegetation is Group F rainforest (excluding wet sclerophyll forest types), mangrove communities and grasslands under 300mm high.	& Vol 2 – QLD 3.10.5.0	1, 2, 3 & 10
Vol 1 – NSW J(A)1 Insulation in accordance with NSW BASIX.	& Vol 2 – NSW 3.12.1	1, 2, 4 & 10
Vol 1 – NSW J(B)1 Insulation in accordance with energy efficiency requirements.		3, 5, 6, 7, 8 & 9
Vol 1 – NT & QLD Section J Insulation in accordance with energy efficiency requirements of BCA 2009 Section J.		2, 3, 4, 5, 6, 7, 8 & 9
Vol 2 – NT Part 3.12 Insulation in accordance with building fabric requirements of BCA 2009 Part 3.12.		1 & 10
General Internal linings to be designed & specified in accordance with internal linings manufacturer guidelines or by a suitably qualified building professional.		1, 2, 3, 4, 5, 6, 7, 8, 9 & 10
General The wall system shall be designed & specified by a suitably qualified design professional and installed by suitably qualified and trained building professionals, in accordance with the relevant Design & Installation Manuals.		1, 2, 3, 4, 5, 6, 7, 8, 9 & 10



Certificate of Conformity

APPENDIX A – PRODUCT TECHNICAL DATA

A1 Type and intended use of product

Refer to page 1 of this certificate.

A2 Description of product

Refer to page 1 of this certificate.

A3 Product specification

Refer to items 1, 2, 3, 4 & 5 listed in Appendix B2:

- ONE AAC PANEL External Wall System Design and Installation Manual, dated September 2019.
- ONE AAC PANEL Floor System Design and Installation Manual, dated September 2019.
- ONE AAC PANEL Party Wall System Design and Installation Manual, dated September 2019.
- ONE AAC PANEL Dual Boundary Wall System Design and Installation Manual, dated September 2019.
- ONE AAC PANEL Dual Boundary Wall Presentation (DWG & Photos), dated September 2019.

A4 Manufacturer and manufacturing plant(s)

ONE AAC PANEL

485 Campbelltown Rd
Denham Court NSW 2565
Ph: 1300 010 222

www.oneaac.com.au

A5 Installation requirements

Refer to items 1, 2, 3, 4 & 5 listed in Appendix B2:

- ONE AAC PANEL External Wall System Design and Installation Manual, dated September 2019.
- ONE AAC PANEL Floor System Design and Installation Manual, dated September 2019.
- ONE AAC PANEL Party Wall System Design and Installation Manual, dated September 2019.
- ONE AAC PANEL Dual Boundary Wall System Design and Installation Manual, dated September 2019.
- ONE AAC PANEL Dual Boundary Wall Presentation (DWG & Photos), dated September 2019.

A6 Other relevant technical data

Refer to items 1, 2, 3, 4 & 5 listed in Appendix B2:

- ONE AAC PANEL External Wall System Design and Installation Manual, dated September 2019.
- ONE AAC PANEL Floor System Design and Installation Manual, dated September 2019.
- ONE AAC PANEL Party Wall System Design and Installation Manual, dated September 2019.
- ONE AAC PANEL Dual Boundary Wall System Design and Installation Manual, dated September 2019.
- ONE AAC PANEL Dual Boundary Wall Presentation (DWG & Photos), dated September 2019.

And any referenced documents within the technical literature identified in Appendices A3 & A5.

Certificate number: CM 30031

This certificate is only valid when reproduced in its entirety.

Page 5 of 7

APPENDIX B – EVALUATION STATEMENTS

B1 Evaluation methods

The following assessment methods have been used to determine compliance with NCC 2019:

Code Clause	Assessment Method(s)	Evidence of suitability	Evidence reference in B2
NCC Volume One BP1.1	Combination of A2.2 (2) (a) & (c)	Combination of A5.2 (1) (e) & (f) – Expert judgement & Other documentary evidence	Items 1, 2, 3, 4, 5, 6, 7, 8 & 9
NCC Volume Two P2.1.1	Combination of A2.2 (2) (a) & (c)	Combination of A5.2 (1) (e) & (f) – Expert judgement & Other documentary evidence	Items 1, 2, 3, 4, 5, 6, 7, 8 & 9
NCC Volume One BP1.2	Combination of A2.2 (2) (a) & (c)	Combination of A5.2 (1) (e) & (f) – Expert judgement & Other documentary evidence	Items 1, 2, 3, 4, 5, 6, 7, 8 & 9
NCC Volume One FP1.4	Combination of A2.2 (2) (a) & (c)	A5.2 (1) (e) – Expert judgement	Item 17
NCC Volume Two P2.2.2	Combination of A2.2 (2) (a) & (c)	A5.2 (1) (e) – Expert judgement	Item 17
NCC Volume One A5.4	Combination of A2.3 (2) (a) & (b)	Combination of A5.2 (1) (d) & (e) – Test report & Expert judgement	Items 10, 11, 12, 13, 14, 15 & 16
NCC Volume One B1.4 (b) (ii)	Combination of A2.3 (2) (a) & (b)	Combination of A5.2 (1) (e) & (f) – Expert judgement & Other documentary evidence	Items 1, 2, 3, 4, 5, 6, 7, 8, 9, 17 & 24
NCC Volume Two 3.5.4.0	Combination of A2.3 (2) (a) & (b)	Combination of A5.2 (1) (e) & (f) – Expert judgement & Other documentary evidence	Items 1, 2, 3, 4, 5, 6, 7, 8, 9, 17 & 24
NCC Volume One C1.9	A2.3 (2) (a)	A5.2 (1) (d) – Test report	Item 15
NCC Volume One Spec C1.1	Combination of A2.3 (2) (a) & (b)	Combination of A5.2 (1) (d) & (e) – Test report & Expert judgement	Items 10, 11, 12, 13, 14, 15 & 16
NCC Volume Two 3.7.2.4	Combination of A2.3 (2) (a) & (b)	Combination of A5.2 (1) (d) & (e) – Test report & Expert judgement	Items 10, 11, 12, 13, 14, 15 & 16
NCC Volume Two 3.7.3.2	Combination of A2.3 (2) (a) & (b)	Combination of A5.2 (1) (d) & (e) – Test report & Expert judgement	Items 10, 11, 12, 13, 14, 15 & 16
NCC Volume Two 3.7.3.5	Combination of A2.3 (2) (a) & (b)	Combination of A5.2 (1) (d) & (e) – Test report & Expert judgement	Items 10, 11, 12, 13, 14, 15 & 16
NCC Volume Two 3.7.4.3	Combination of A2.3 (2) (a) & (b)	Combination of A5.2 (1) (d) & (e) – Test report & Expert judgement	Items 10, 11, 12, 13, 14, 15 & 16
NCC Volume One F1.9	Combination of A2.3 (2) (a) & (b)	Combination of A5.2 (1) (e) & (f) – Expert judgement & Other documentary evidence	Items 1 & 19
NCC Volume One F5.2	Combination of A2.3 (2) (a) & (b)	Combination of A5.2 (1) (d) & (e) – Test report & Expert judgement	Items 18, 19, 20 & 21
NCC Volume One F5.3	Combination of A2.3 (2) (a) & (b)	Combination of A5.2 (1) (d) & (e) – Test report & Expert judgement	Items 18, 19, 20 & 21
NCC Volume One F5.4	Combination of A2.3 (2) (a) & (b)	Combination of A5.2 (1) (d) & (e) – Test report & Expert judgement	Items 18, 19, 20 & 21
NCC Volume One F5.5	Combination of A2.3 (2) (a) & (b)	Combination of A5.2 (1) (d) & (e) – Test report & Expert judgement	Items 18, 19, 20 & 21
NCC Volume Two 3.8.6.2	Combination of A2.3 (2) (a) & (b)	Combination of A5.2 (1) (d) & (e) – Test report & Expert judgement	Items 18, 19, 20 & 21
NCC Volume Two 3.8.6.3	Combination of A2.3 (2) (a) & (b)	Combination of A5.2 (1) (d) & (e) – Test report & Expert judgement	Items 18, 19, 20 & 21
NCC Volume Two 3.8.6.4	Combination of A2.3 (2) (a) & (b)	Combination of A5.2 (1) (d) & (e) – Test report & Expert judgement	Items 18, 19, 20 & 21
NCC Volume One G5.2	Combination of A2.3 (2) (a) & (b)	Combination of A5.2 (1) (d) & (e) – Test report & Expert judgement	Items 10, 11, 12, 13, & 16
NCC Volume Two 3.10.5.0 (c)	Combination of A2.3 (2) (a) & (b)	Combination of A5.2 (1) (d) & (e) – Test report & Expert judgement	Items 10, 11, 12, 13, & 16
NCC Volume One J1.5	Combination of A2.3 (2) (a) & (b)	A5.2 (1) (e) – Expert judgement	Items 22 & 23
NCC Volume Two 3.12.1.4	Combination of A2.3 (2) (a) & (b)	A5.2 (1) (e) – Expert judgement	Items 22 & 23



Certificate of Conformity

B2 Reports

The following reports have been used as evidence to determine compliance with NCC 2019:

Ref	Author	Reference	Date	Description	NATA Registration
1	ONE AAC PANEL	External Wall D&I Guide	Sept 2019	Client published design & installation manual	-
2	ONE AAC PANEL	Flooring D&I Guide	Sept 2019	Client published design & installation manual	-
3	ONE AAC PANEL	Party Wall D&I Guide	Sept 2019	Client published design & installation manual	-
4	ONE AAC PANEL	Dual Zero Boundary D&I Guide	Sept 2019	Client published design & installation manual	-
5	ONE AAC PANEL	Dual Zero Boundary Details	July 2019	Client published drawings and details	-
6	Energren	NCC Vol 2 Compliance – Dual Zero	7 Aug 2019	Compliance review of ONE AAC systems against NCC	-
7	Energren	BCA Compliance CodeMark	9 Apr 2013	Compliance review of ONE AAC systems against NCC	-
8	ONE AAC PANEL	LOXO Batch Testing 50mm Panel	15 Mar 2018	Quality control structural test document	-
9	Energren	AS4055-2006 Connection Design	13 Apr 2009	Structural calculation report	-
10	CSIRO	FSV 1525	15 Feb 2012	Fire test report	165
11	CSIRO	COT 2363	15 Feb 2012	Fire test certificate	165
12	CSIRO	FCO 2915	30 Mar 2012	Fire assessment report	165
13	CSIRO	FCO 2944	29 Aug 2012	Fire assessment report	165
14	CSIRO	FCO 3023	20 Sep 2013	Fire assessment report	165
15	CSIRO	FNC-11128	9 May 2014	Fire test report	165
16	CSIRO	FCO 3111	20 Apr 2014	Fire assessment report	165
17	Energren	ONE AAC Weatherproofing	5 Sep 2019	Weatherproofing assessment	-
18	Renzo Tonin & Assoc	TG553-01F02	6 Feb 2014	Acoustic assessment report	-
19	Koikas Acoustics	2679C20150827	3 Jun 2015	Acoustic assessment report	-
20	Koikas Acoustics	2878C20151112	12 Nov 2015	Acoustic assessment report	-
21	Koikas Acoustics	2878C20181031	9 Nov 2016	Acoustic assessment report	-
22	Energren	LOXO Panel R Value	27 Nov 2015	Thermal assessment report	-
23	Energren	LOXO Wall 75mm R Values	9 Apr 2013	Thermal assessment report	-
24	Standards Australia	AS5146 (Parts 1, 2 & 3)	2015	Australian Standard	-

The Certificate Holder has chosen not to make the above identified evidence of compliance publicly available, due to the documents being considered commercial in confidence.

End of Certificate.

Gallery

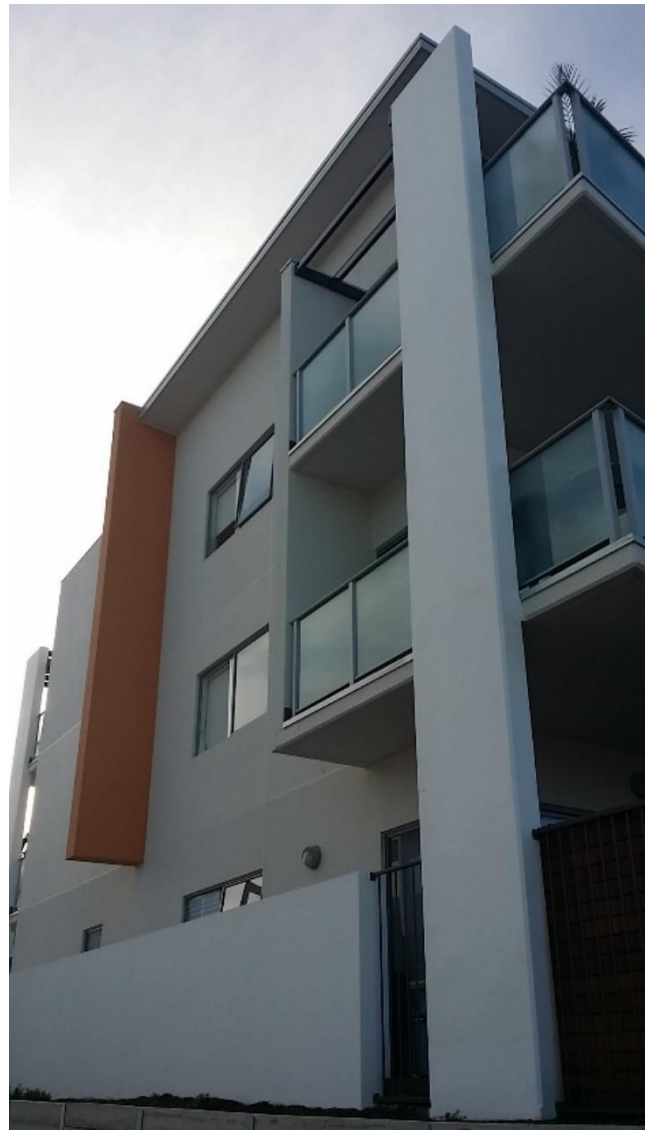

Notes:

ONE AAC PANEL

Head Office:

485 Campbelltown Rd

Denham Court NSW 2565

Tel: **1300 010 222 (AAC) or 02 9756 5029**

Mobile: 0439 28 30 30

Email: info@oneaac.com.au

Web: www.oneaac.com.au