



ONE AAC

PANEL

AAC FIRE & ACOUSTIC SOLUTIONS



50mm & 75mm AAC PANEL PARTY WALL SYSTEMS

DESIGN & INSTALLATION MANUAL

MAY 2025 Edition

Preface

The ONE AAC PANEL Party Wall System Design & Installation Manual has been developed to provide design, installation and technical information to 'end users' ranging from the owner builder, licensed builders, building consultants, designers, architects and engineers.

Although the details provided in this Design & Installation Manual have been developed by ONE AAC and are intended to represent good building practice, the registered professionals involved in the project (such as the licensed builder, architectural designer and engineering consultant) must ensure that the information provided in this Design & Installation Manual is appropriate and suitable for the project.

Contents

Introduction To ONE AAC	3-4
❖ What is AAC	
❖ Manufacturing Process	
BCA & Australian Standards Compliance	5
❖ Compliance with Required Standards	
System Overview & Performance	6-7
❖ Material Properties	
❖ Fire Resistance	
❖ Acoustic Performance	
❖ Design Principles	
System Components	8-9
❖ Panel	
❖ Panel Adhesive	
❖ C-Section Base Track (Optional)	
❖ H-Section Joiner Stud	
❖ Slotted Angle	
❖ Metal Battens	
❖ Aluminum Brackets	
❖ Fasteners	
❖ Fire Rated Sealant	
System Selection & Installation Process	10-13
❖ System Installation Sequence	
❖ Installation Summary	
❖ Tools & Equipment	
Delivery Storage & Handling	14
❖ Delivery	
❖ Storage and Handling	
Occupational Health and Safety	14
Warranty & Guarantee	15
Drawings & Details	16-21
CodeMark Certificate Of Conformity	22

Introduction

ONE AAC Panel is known as a market leader in AS5146 compliant Aerated Autoclaved Concrete (AAC) Panel Solutions for residential and commercial construction.

ONE AAC combines 30 years of construction experience, product and systems development knowledge and material distribution expertise, to ensure its customers receive the best construction solutions for their projects, at the best possible price, with the fastest possible turnaround.

ONE AAC supplies to the construction industry and specialises in **Fire** and **Acoustic** Solutions for **wall** and **floor** systems, in both **commercial** and **residential** applications.

Solutions include, but are not limited to:

- **Internal Wall Systems (Intertenancy / Party Walls) – Low Rise and High Rise**
- External Rendered Wall Systems – Low Rise and High-Rise Façades
- Boundary Walls - Single and Dual Wall Options
- Floor and Ceiling Systems
- Fence Systems - Boundary and Estate Fencing Solutions

**Solutions Can Be Resolved in 50mm or 75mm Thick
ONE AAC PANEL - The Choice is Yours.**

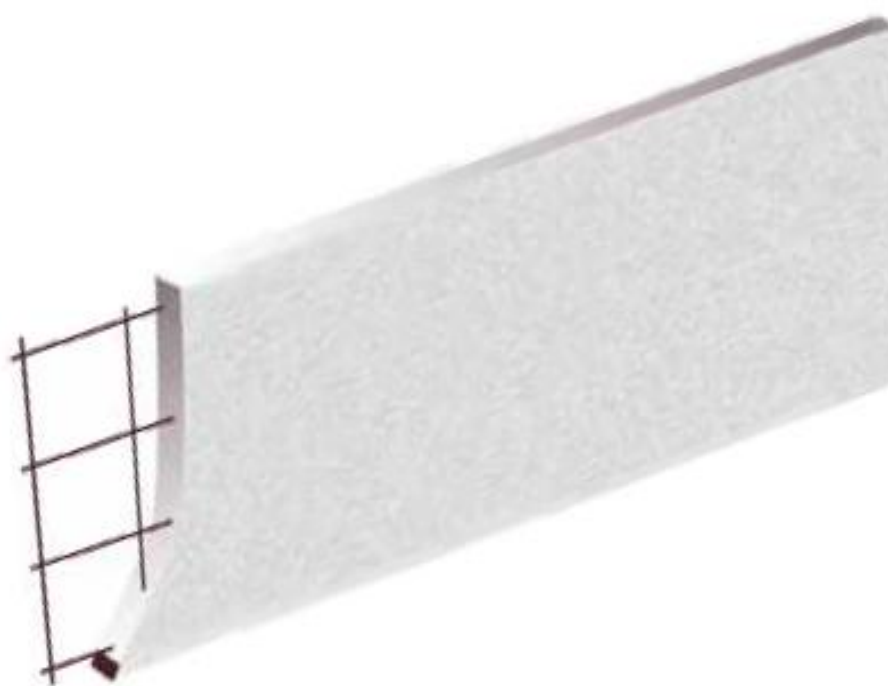

STEEL REINFORCED - 50MM AND 75MM ONE AAC PANEL

What Is AAC? (Lightweight Concrete)

Autoclaved Aerated Concrete (AAC) is manufactured from cement, sand (silica), lime and water, it is aerated by adding an expanding agent to the mix (small amounts of aluminium paste). The mix is poured into a mould (a very large cake tin), to approximately 2/3 of the height of the mould, almost instantly the expanding agent reacts with the other elements, and the mix begins to rise in the mould. (A chemical reaction expands the mixture to form small, finely dispersed air bubbles).

The moulds are pre-cured in a heated room for several hours. Then the semi -solid material (still in a green state) is transported to the cutting machine. The soft but semi-solid block is sliced into the required panel size using steel wires. Once sliced, the block is steam pressure cured in autoclaves for up to 12 hours. The expanding chemical reaction combined with the Autoclave process is what gives AAC it's unique properties. AAC has excellent thermal insulation and acoustic absorption properties, it has superior fire resistance qualities and is also termite resistant.

Its properties and specification satisfy all relevant building codes. Working with AAC is easy and efficient. AAC is both versatile and economical. AAC meets the diverse demands better than any other material due to the numerous advantages of its physical and mechanical properties.

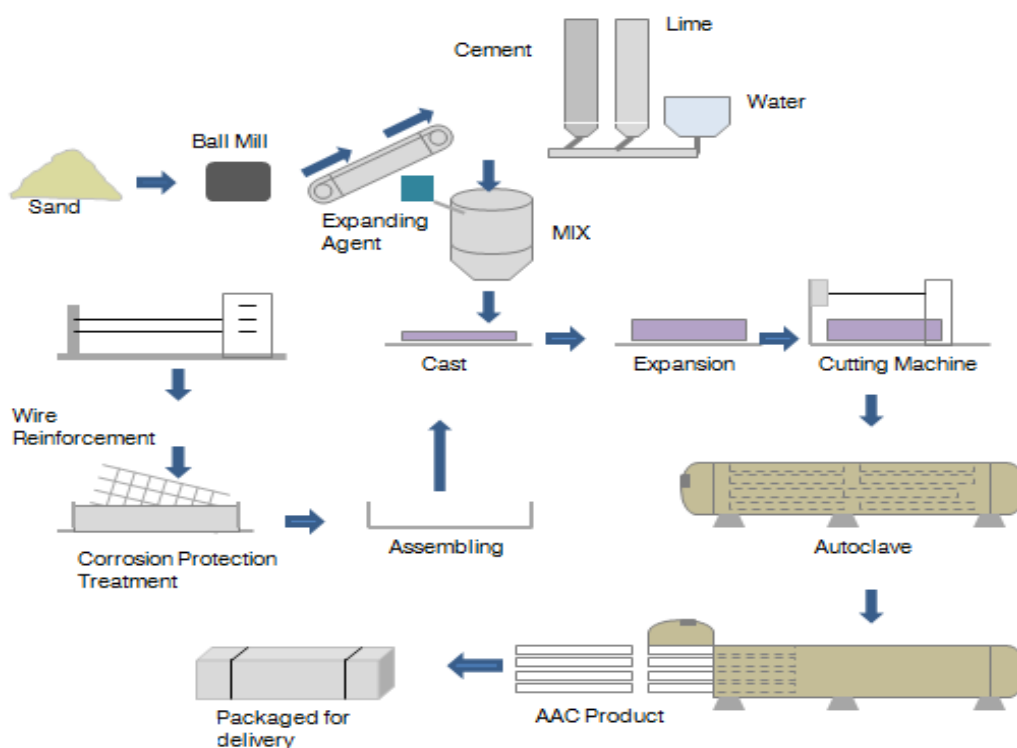

THE ONE AAC PANEL MANUFACTURING PROCESS

The ONE AAC Panel System – BCA / NCC Compliance

The BCA is part of the Australian National Construction Code system and defines minimum standards for buildings. The BCA consists of two volumes:

Volume One - provides requirements for commercial, residential and public building defined as Class 2 to 9 in the BCA. Typical examples include offices, commercial, health buildings, flats and boarding houses.

Volume Two – Housing Provisions, considers domestic construction defined as Class 1 and 10. Typical examples include houses, garages, swimming pools, carports and the like. The BCA is a performance-based building code and contains requirements for Structures, Fire Resistance, Damp & Weatherproofing, Sound Transmissions & Insulation and Energy Efficiency.

The ONE AAC Panel System has been assessed to meet and comply with all the necessary performance requirements of the BCA. This design & Installation Manual contains the information necessary to assist in the design of a project.

The designer should ensure the proposed use of the system satisfies the Performance Requirements and provides sufficient design information (including ONE AAC appraisal and installation manuals) to satisfy the requirements of the appropriate authority.

ONE AAC Panel has achieved the CODEMARK CERTIFICATE OF CONFORMITY issued by Global-Mark in Australia (Certificate Number GM_CM30031 Rev 4) to meet all the required provisions of the Building Code of Australia **for Volume One and Volume Two** and has been appraised as an **Alternative Solution** in terms of compliance with the Building Code of Australia as listed below:



CATEGORY	BCA VOLUME 1	BCA VOLUME 2	ABCB HOUSING PROVISIONS
Structural Reliability & Resistance	B1P1, B1P2, B1D4	H1P1, H1D7	N/A
Fire Safety	C2D2, C2D10 Specification 1 Specification 5	H3D3, H3D4, H3D5 Specification 1	9.2.3 9.3.1 & 9.3.4 9.4.1
Weatherproofing Damp Proofing	F1D6, F3D5	H2D6	N/A
Sound Insulation	F7D3, F7D4, F7D5, F7D6	H4D8	10.7.1, 10.7.2 & 10.7.3
Bushfire Construction	G5D3, G5D4	H7D4	N/A
Energy Efficiency – External Walls	J4D6	H6D2	13.2.5

The Code Mark Certificate is attached in the Appendix of this Design and Installation Manual or visit www.oneaac.com.au to download a copy.

Australian Standard Compliance

All works shall be carried out in accordance with the BCA and where necessary nominated reference standards.

AS 5146 (Parts 1, 2 & 3) - Reinforced Autoclaved Aerated Concrete

- Horizontally oriented ONE AAC panels -refer to tables 3.3G, 3.3H & 3.3I in AS5146.3
- Vertically oriented ONE AAC panels - refer to Tables 3.3A, 3.3B, 3.3C, 3.3D, 3.3E & 3.3F in AS5146.3.

AS 1720 Timber Framing Code and AS 1684-2006 National Timber Framing Code

AS 2870-1996 Residential Slabs and Footing Construction and AS 3600-2001 Concrete Structures

AS 3959-2009 Construction of Buildings in Bushfire-Prone Zone Areas

AS 2904-1995 Damp-proof course and flashings

AS 1170 Part 1 Loading Code and AS 1170 Part 2 Wind Code

AS 3660.1-2001 Protection of Buildings against subterranean Termite – Part 1 New Buildings

AS 4055-2006 Wind Loading for Housing

AS 3623 and AS/NZ 4600 – Steel Framing and NASH Standard 2005, Part 1 – Steel Framing

Where standards have been revised, the most current version shall apply

Material Properties

Property	50MM PANELS		75MM XL PANELS	
	Value	Units	Value	Units
Ambient ¹ Density, ρ_{amb} (10% Moisture Content)	561	kg/m ³	440	kg/m ³
Dry ² Density, ρ_{dry}	510	kg/m ³	400	kg/m ³
Working ³ Density, ρ_{design} (35% Moisture Content)	689	kg/m ³	540	kg/m ³
Characteristic Compressive Strength of AAC $f'm$	2.8	MPa	2.38	MPa
Average Compressive Strength of AAC	3.2	MPa	2.8	MPa
Characteristic Modulus of Rupture, f'_{ut}	0.6	MPa	0.4	MPa
Design Ultimate Limit State Bending Capacity, ϕM	0.12	kNm	0.25	kNm
Design Serviceability Limit State Deflection Limit, δ_{max}	$SPAN/240$		$SPAN/240$	
Coefficient of contraction	0.4	mm/m	0.4	mm/m
Coefficient of thermal expansion	10	$\times 10^{-6}/^{\circ}C$	10	$\times 10^{-6}/^{\circ}C$

Notes:

1. Ambient density is that achieved by the product when it has reached equilibrium at 23°C, 50% RH. The moisture content by mass in this state is typically between 10% and 15%.
2. Dry density is the manufacturer's reported density, the typical frame of reference for grading AAC material. It is achieved by oven drying specimens so that the moisture content is 0%.
3. Working density is to be used for calculation of effects due to permanent actions.
4. Moment capacity quoted is for 600mm wide panels.

Quality from start to finish

ONE AAC and associated manufacturers both adhere to the ISO 9001 international standards for management of quality. With these measures in place plus strict system protocol ONE AAC offers a warranty of 15 years on materials adding peace of mind to your project.

Fire Resistance

AAC materials have exceptional fire resistance and are non-combustible. In the event of fire ONE AAC Panels will not emit any toxic gases or vapours. The ONE AAC Panel System meets the performance requirements of P2.3.1 of the BCA for use as a Party Wall, providing FRL's options of 60/60/60 or 90/90/90 or 120/120/120 – (all options are supported via CSIRO Reports and Assessments).



Photo courtesy of www.budwell.com

Acoustic Performance

The ONE AAC Party Wall Systems offers good acoustic performance. The acoustic performances, meet and exceed the minimum BCA requirements. To further increase the acoustic performance, the use of sound insulation materials and sound rated plasterboard is recommended.

- The Bare 50mm ONE AAC Panel has an $R_w = 33$
- The Bare 75mm ONE AAC Panel has an $R_w = 35$
- The ONE AAC PANEL Party Wall Systems achieve the minimum $R_w + C_{tr} = 50$
- They comply with the requirements for Discontinuous Construction

Design Principles for the ONE AAC Panel System

The design principles which the ONE AAC Panel System are based on, are those used in both residential framed construction as well as residential concrete frame with light weight frame infill construction.

Multi Storey Construction

ONE AAC Panels can be used for both Low Rise and High Rise Multi-Residential construction when fixed in accordance with the ONE AAC Panel Systems

Framing Design for the ONE AAC PANEL System

In either, Load Bearing (typically low rise framed construction) or Non - Load Bearing (typically high-rise slab to slab construction) residential projects, the support structure including the stud frame, shall be designed by the frame manufacturer or the relevant design engineer, and should be designed in accordance with the specific codes for concrete, timber or steel frame construction types.



ONE AAC



PARTYWALLS

ONE AAC Panel System Components

ONE AAC PANELS

The ONE AAC Panels are steel reinforced and are manufactured from autoclaved aerated concrete with a dry density of 520kg/m³-560kg/m³ for 50mm panel and a dry density of 400kg/m³-440kg/m³ for 75mm panel. The ONE AAC Panels are supplied in a length ranging from 2200mm up to 3000mm for 50mm panels and 2400mm up to 3300mm for 75mm panels and a standard width of 600mm and have an average mass of approx. **40kg/panel for the 2200mm x 50mm thick panels** and approx. **79kg/panel for the 3000mm x 75mm thick panels**.

ONE AAC PANEL Adhesive

The ONE AAC Panel Adhesive is a polymer modified cement-based adhesive supplied in 20kg bags. It is supplied by ONE AAC, mixed on-site with clean water (see instructions printed ONE AAC bag), and is applied to all edges of the panels (except control joint). ONE AAC Panel Adhesive is also used for bonding Decorative Trims and banding, along with minor patching, repairs and stopping of screw heads on the ONE AAC panels.

Base Channel / C-Section Channel

The 51mm x 28mm x 0.5 BMT C-Section when used as a base or end channel abutting masonry, is to be fixed using M6 masonry anchors at a max of 1800mm centres. When used as end channels of load bearing framed party walls, they must be fixed via aluminium brackets to the periphery (end studs) at a maximum of 1500mm centres. For slab to slab (non-load bearing) construction, the end C-Section Channel is located within the base channel at the base and fixed at the top to a slotted angle.



H-Section Joiner Stud (60 Minute Systems)

The 51mm x 0.5 BMT H-Section Joiner Stud are located at a maximum of 2200mm centres and are fixed at the bottom and top of each 3200mm H-Stud, typically at intersecting floor, ceiling and rafter levels at either side of the AAC Wall. For slab to slab (non-load bearing) construction, the H-Section Joiner Stud is located within the base channel at the base and fixed at the top to a slotted angle.

Slotted Angle / Top Angle

The 75mm x 50mm x 1.15BMT slotted angle is used for the slab to slab (Non-Load Bearing) is fixed to the concrete ceiling at 600mm centres using masonry anchors or shot fired nails to withstand a minimum shear load of 0.80kN/m (based on a 4.2m high wall at 0.375 kPa ultimate wind pressure)

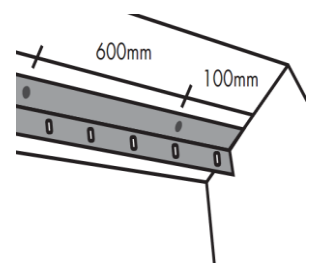

16mm Metal Batten (90 Minute Systems)

The 16mm x 0.5 BMT Metal Battens are located (one side of AAC Wall only) at a maximum of 1100mm centres and are fixed to each intersecting bottom plate, top plate, bottom chord and rafter. For slab to slab (non-load bearing) construction, the 16mm Metal Batten is fixed to the outside of the base channel at the base and fixed at the top to a slotted angle.

Aluminium Brackets

The 70 x 40 x 1.5 x 50mm wide Aluminium Brackets are used to connect the timber or steel frame either side of the AAC panel wall. The Aluminium Brackets are typically fixed at maximum of 3000mm vertical spacings and at approximately 1100mm horizontal spacings at:

- The bottom plate, except when the base track option is used, and when the H-Stud from the previous floor level extends past the bottom plate of the floor above and it is already fixed to the top plate from the level below
- each top plate
- and the rafter level / top of the roof height



Timber Frame Screws

12-11 x 25mm Hex Head Type 17 screws are used to fix the aluminium brackets to the timber frame. Two screws per bracket are required.



Steel Frame Screws

10-16 x 16mm Hex Head Self Drilling Screws are used to fix the aluminium brackets to the Metal C-Section Channel or the Aluminium Brackets to the Metal H-Section Joiner Studs. Two screws per bracket are required.



Panel Screws

14-10 x 45mm Hex Head Type 17 screws are used to fix the aluminium brackets to the AAC Panel at mid span. Two screws per bracket are required. As fixings into the AAC are prone to being over tightened and stripping, it is good practice to drive each of the two screws in opposites directions (a slight direction away from each other)



Fire Rated Sealant

An approved fire rated sealant such as SWIRL Engineering, Knauf Bindex, Fullers FIRESOUND Fire Rated Acoustic Sealant or Bostik FIREBAN ONE Low Modulus Fire Rated Polyurethane Sealant or equivalent must be used in control joints in all fire rated wall applications such as boundary walls.



System Selection & Installation Process

System Selection

SYSTEM	PANEL	CONSTRUCTION TYPE	FRL	Rw+Ctr
1 – 60 LB Stack Bond & Vertical H-Stud	50mm	Framed: Timber or Steel Frame	60/60/60	53
1S – 60 NLB Stack Bond & Vertical H-Stud	50mm	Slab to Slab: Timber or Steel frame infill	-/60/60	53
2 – 90 LB (H-Stud Not Permitted) Stretcher & Vertical	50mm	Framed: Timber or Steel Frame	90/90/90	53
2S – 90 NLB (H-Stud Not Permitted) Stretcher & Vertical	50mm	Slab to Slab: Timber or Steel frame infill	-/90/90	53
3 – 120 LB Vertical Panel	75mm	Framed: Timber or Steel Frame	120/120/120	55
3S – 120 NLB Vertical Panel	75mm	Slab to Slab: Timber or Steel frame infill	-/120/120	55

Benefits

- Systems comply with the minimum requirements of the BCA for Fire and Acoustics for Discontinuous Construction
- Simple and easy to install, which can be installed by existing trades for continuity of work.
- Does not require the use of fire rated plasterboard to achieve the fire rating.
- Weather resistant during construction, the AAC panels will not bend, soften, grow mold or deteriorate in wet weather
- Fast and achieves significant cost savings over traditional masonry systems



ONE AAC Horizontal Panel System Installation Sequence – 50mm Panel

- **Fix C-Section to end of wall:** Via Aluminium Brackets for framed constructions or to base channel and slotted angle for slab-to-slab construction

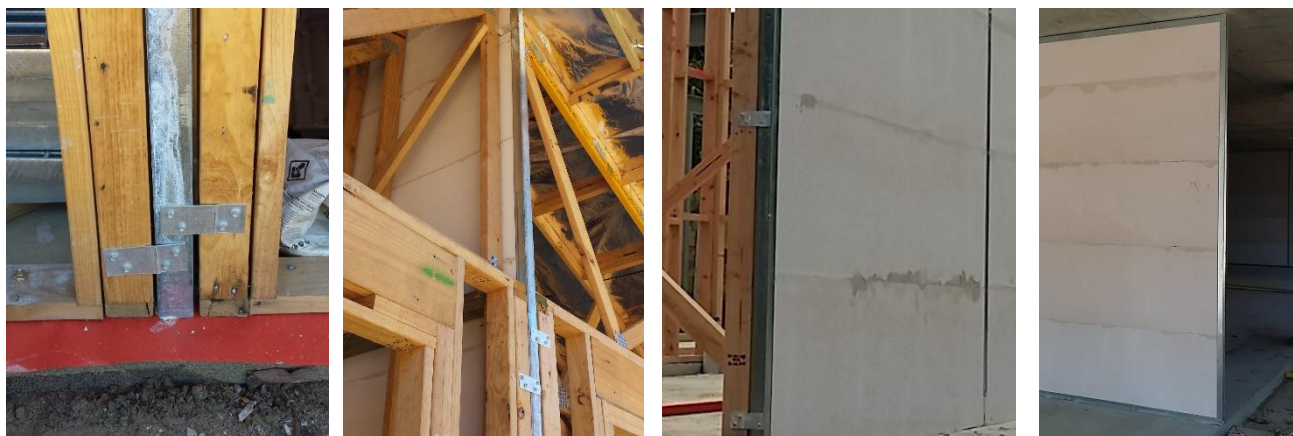

- **Choose Base Detail:** Adhesive or Base Channel Option



- **For Stretcher Bond System** (90 minute systems): fix first metal batten at 1100mm centers starting with the first metal batten at 550mm from end of wall.

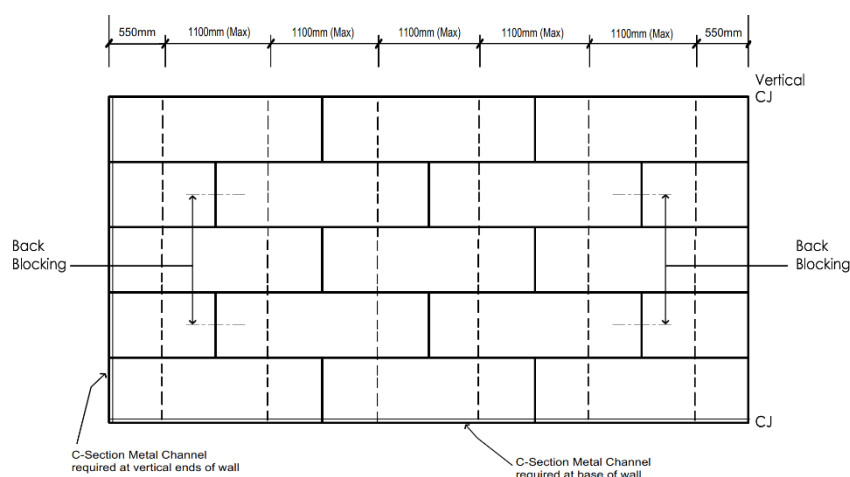

- **Mix Panel Adhesive**

- **Install Panel:** For **Stack Bond** installation, panels are laid one panel on the other in a stack bond pattern and are located within the H-Section Joiner Studs. For **Stretcher Bond** installation, the panels are fixed to the metal battens (2 screws per intersecting batten), either rear fixed using 45mm or 65mm hex head screws or face fixed using 75mm bugle head screws. The face fixed screws are to be embedded at a minimum of 5mm and patched over using the ONE AAC adhesive.

- **Apply Adhesive:** ONE AAC PANEL Adhesive is only required to the horizontal joints for the stack bond system (the adhesive is not required at the H-Section Joiner Stud), however it is required to both the horizontal and vertical panel joints for the stretcher bond system.
- **Aluminium Bracket Installation:** Brackets should be fixed at 1100mm (nominal) horizontal spacings and a maximum of 3000mm vertical spacings. The Aluminium Brackets are typically fixed at the bottom and top of each wall element and at intersecting floor, ceiling and rafter levels at either side of the AAC Wall.



- **Continue Panel Installation** to the perimeter intersections such as the external walls, roof line, slab ceiling etc.
- **Perimeter Intersections** are to be treated to prevent fire, sound and smoke passing through the AAC panel wall. Intersecting T-Junctions may be Cavity Type or Non-Cavity Type intersections.

- **Cavity Type Intersections** are to be packed tightly with Fire Resistant Mineral Wool, all intersections with external walls will also require damp proof course between the external wall and the mineral wool to prevent moisture wetting the mineral wool and causing it to become displaced.
- **Non-Cavity Type Intersections** are to be sealed with a bead of Fire Rated Sealant beneath and to at least one vertical side of the metal C-Section Channel which is fixed to the intersecting T-Junction. Ensure panels are completely inserted into the C-Section Channels.

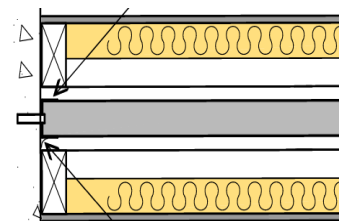
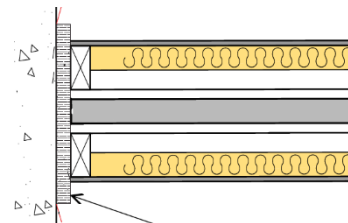

- **Eaves Detail and Temporary Bracing:** Panels can be canter-levered to close the eaves void, and walls should not be left unbraced as they may be prone to be blown over if left unbraced.



Basic Tools Required When Working With AAC

The basic tools required when working with AAC are typically used by the carpentry and rendering trades and are readily available and relatively inexpensive when it comes to the complete set up for working with AAC.

Some of the tools required to make the job easy are identified below:

- ◆ Personal Protective Equipment
 - High Visibility Work Wear, Steel Cap Boots
 - Gloves, Dust Mask, Goggles, Hearing Protection
- ◆ Standard Contractor Tools
 - Hammer, Nail Bag, Tape, Pencil, Level
 - Tin Snips, Chisels, Knife
 - Electric Leads and Power Box
- ◆ Power Saw
 - Preferably Dustless
 - Fitted with a Diamond Blade
- ◆ Vacuum
- ◆ Power drill / Mixing Drill / Mixing Buckets
- ◆ Cordless Drills and Drive Bits
- ◆ Grinder / Reciprocator Saw
- ◆ Adhesive Trowel
- ◆ Hawk and Steel Trowel
- ◆ Nail or Staple Gun
- ◆ Sanding Float / Rasp



Delivery Storage & Handling

Delivery

One AAC Panels shall be unloaded or moved with approved lifting devices. For transport and lifting purposes the wet mass of the panels should be used to ensure that overloading is avoided. The wet mass is calculated by adding between 10-20%% to the noted pack weight. To minimise double handling and save time the packs should be unloaded as close as possible to the installation area. ONE AAC Panel packs should only be stacked one pack high (on site) and properly supported on level ground. Always consult the project engineer as to the adequacy of the structure to support the packs if they are to be placed on any part of the structure.

Storage

All ONE AAC material should be kept dry and preferably under cover, all care should be taken to avoid damage to the face, ends and edges of the panels. When ONE AAC Panels are stored outside they must be off the ground and protected from the weather.

Manual Handling

Physical manual handling of ONE AAC Panels around the work site should be kept to a minimum, always carry the panels on edge, and support the weight by a two man lift procedure. Where the manual handling becomes excessive with respect to distance from the installation area, ONE AAC recommends the use of trolleys and/or other mechanical devices.

Occupational Health & Safety (OH&S)

ONE AAC Panels, along with all clay, concrete and quarry products contain Crystal line Silica, or Silica Dust. Prolonged exposure to Silica dust without the correct Personal Protection Equipment can be harmful and potentially cause life threatening health hazards such as bronchitis, silicosis and lung cancer.

The ONE AAC Panel itself does not cause health problems, however when cutting, drilling, chasing, sanding, etc., the exposure to high volumes of dust is increased, which increases the potential for health problems to occur, unless standard precautionary measures are taken. Repeatedly breathing in high volumes of dust over many years, may lead to health problems.

It is most unlikely to breath in high volumes of fine silica dust when stacking, loading or laying panels, however when cutting, drilling, chasing, sanding, etc., it is imperative that safety masks, hearing and eye protection is worn. Ensure the mask fits properly and is approved for use with dust. Protective clothing should also be worn e.g. high visibility long sleeve shirt and long pants. These should be washed often and not in the same wash as other clothes.

The site should be cleaned of dust every day, and when using power tools these should be tagged for use as required and be fitted with efficient and well-maintained dust extraction devices. The ONE AAC Panel Installer on site has a responsibility to inform all employees of these Health and Safety requirements under the Occupational Health and Safety Act.

Personal Protective Equipment (PPE)

When working with AAC, ONE AAC recommends (as a minimum) that the following PPE is worn:

- ◆ P1 or P2 Dust masks – complying with AS/NZS1715 and AS/NZS1716
- ◆ Glasses / Goggles - complying with AS1336
- ◆ Ear Plugs / Ear Muffs – Class 5
- ◆ Gloves, long sleeve shirt and pants – to prevent possible skin irritation and skin cancer from working outdoors
- ◆ Steel Cap Boots

Cutting

ONE AAC Panels can be easily cut, drilled, or chased using power or hand tools. When working with ONE AAC Panels ensure that the PPE as previously described is worn. As an added measure of containing the dust when working with AAC products, ONE AAC recommends the use of dust extraction equipment.

ONE AAC Panel makes cutting easier for the installer, as they are delivered to site flat packed, essentially each pack of panel is its own cutting bench, simply adjust the depth of the saw blade to the thickness of the panel and cut the required panels before removing it from the pack. Any exposed reinforcement during cutting must be coated with the ONE AAC Panel Corrosion Protection Touch Up Paint. For a copy of the full range of ONE AAC Panel MSDS sheets, visit the website; www.oneaac.com.au

Hazardous Materials

With reference to the BCA, regarding Hazardous Building Materials, AAC Panels are non-hazardous, provided that all safety precautions included in this literature are adhered to.

Warranty & Guarantee

ONE AAC Panels are quality building products, and come with the following Warranty and Guarantee:

Warranty

ONE AAC Panels and associated materials, when installed as party wall systems, are warranted for a minimum of **15 years** (from the date of purchase), not only meeting, but exceeding the **7-year** requirement outlined in the BCA and the relevant Australian Standards. The ONE AAC Panel products are designed to have a life span significantly in excess of this minimum period.

Guaranteed

ONE AAC Panel Autoclaved Aerated Concrete products are guaranteed to be free of defect in material and manufacture.

For further details or information on the engineering, design and construction with the ONE AAC Panel System, please contact our sales or technical professionals on 1300 010 222 or visit our website: www.oneaac.com.au to obtain the latest Design & Installation Manuals.



50MM AAC PANEL SYSTEMS – UPTO 60 MINUTE FRL

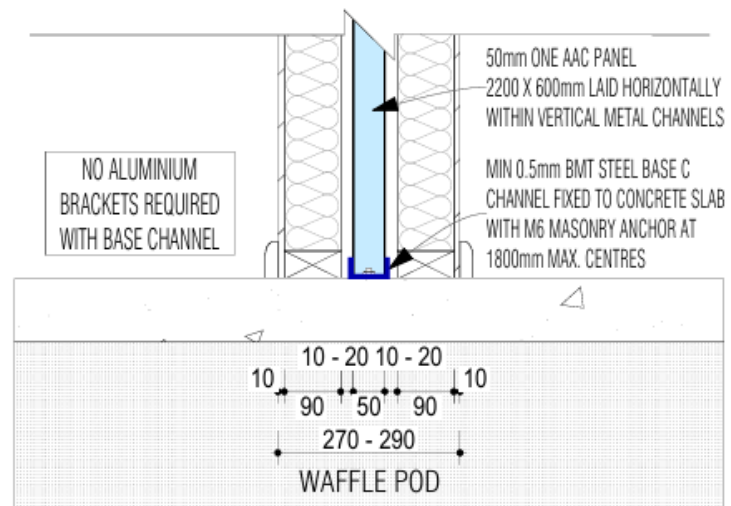
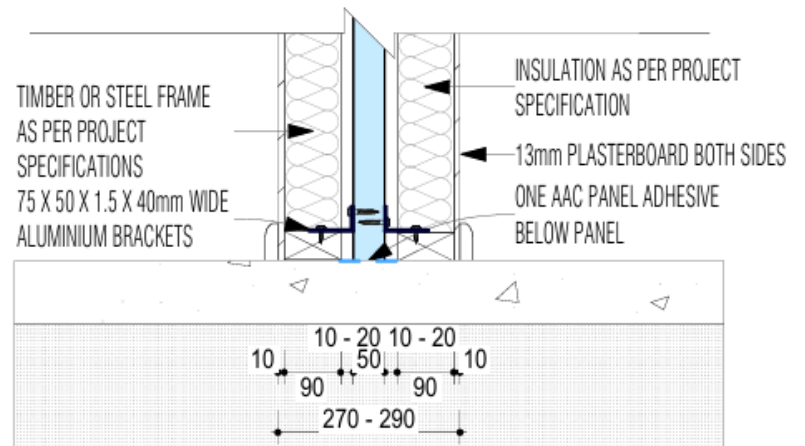
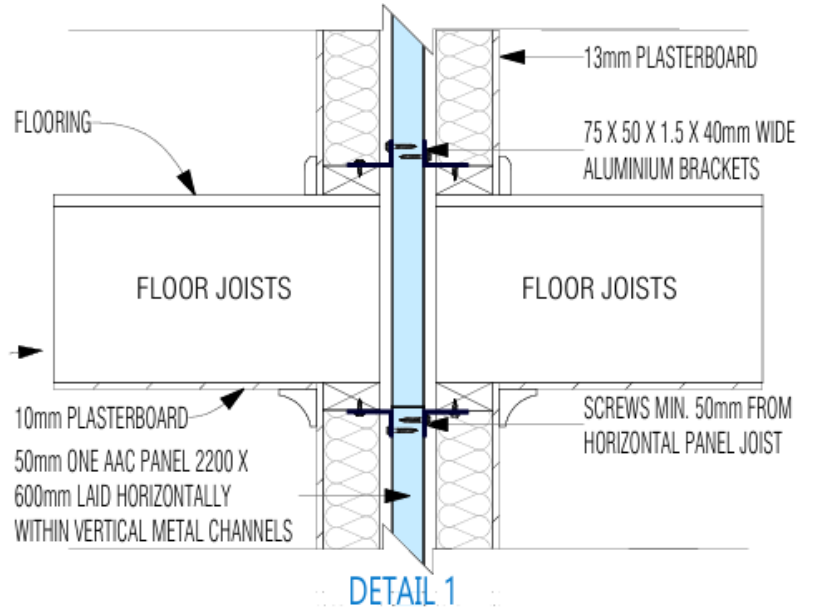
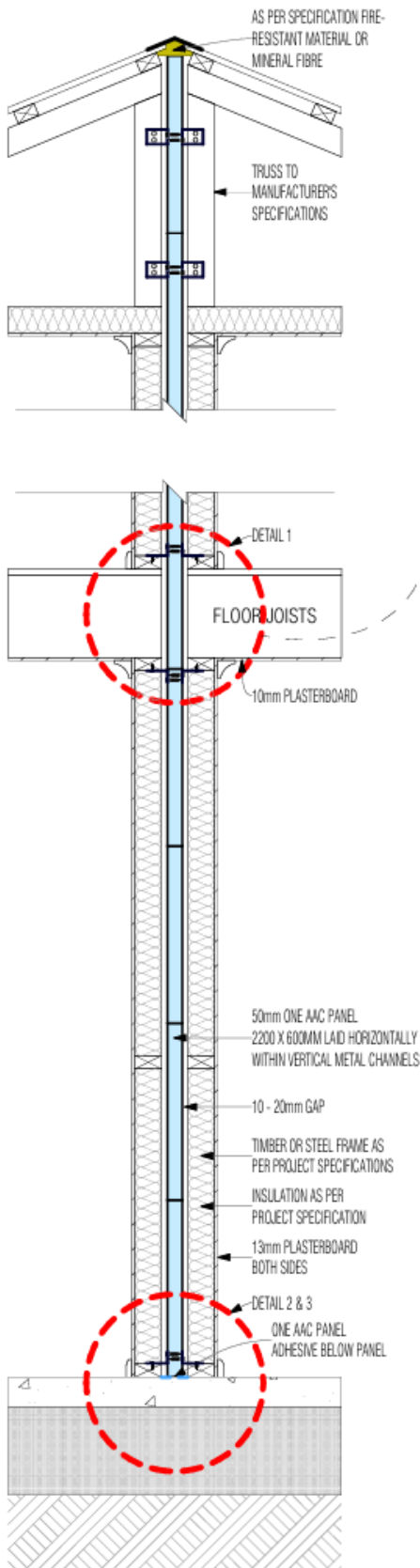

ONE AAC PANEL – 50MM PARTY WALL DETAIL

FRL 60/60/60 Rw + Ctr 53

50MM AAC PANEL SYSTEMS – UPTO 60 MINUTES FRL

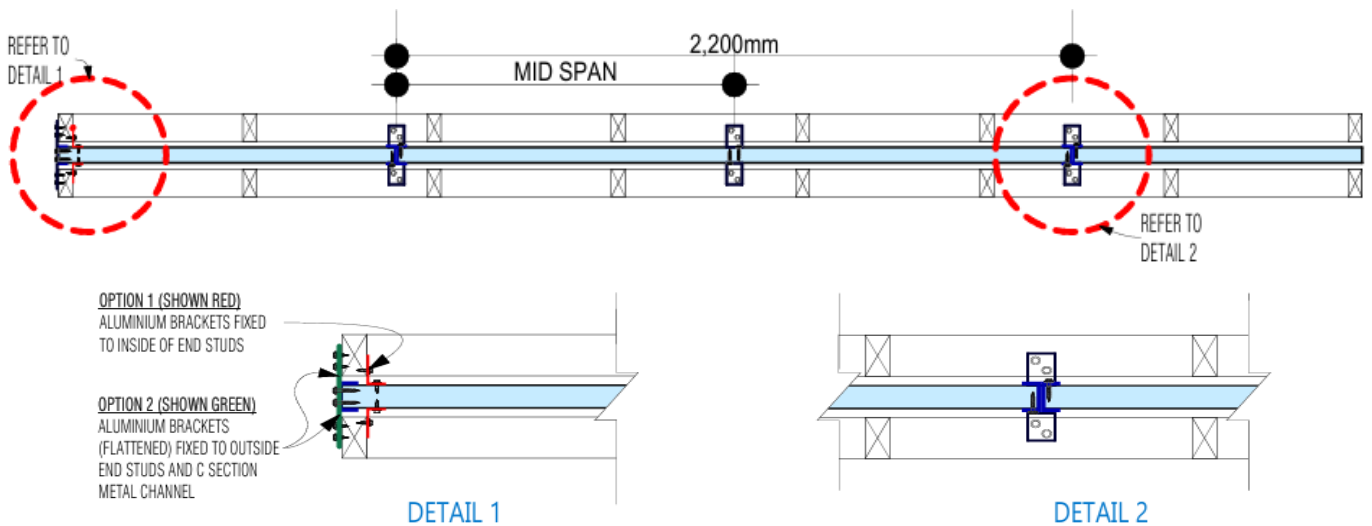
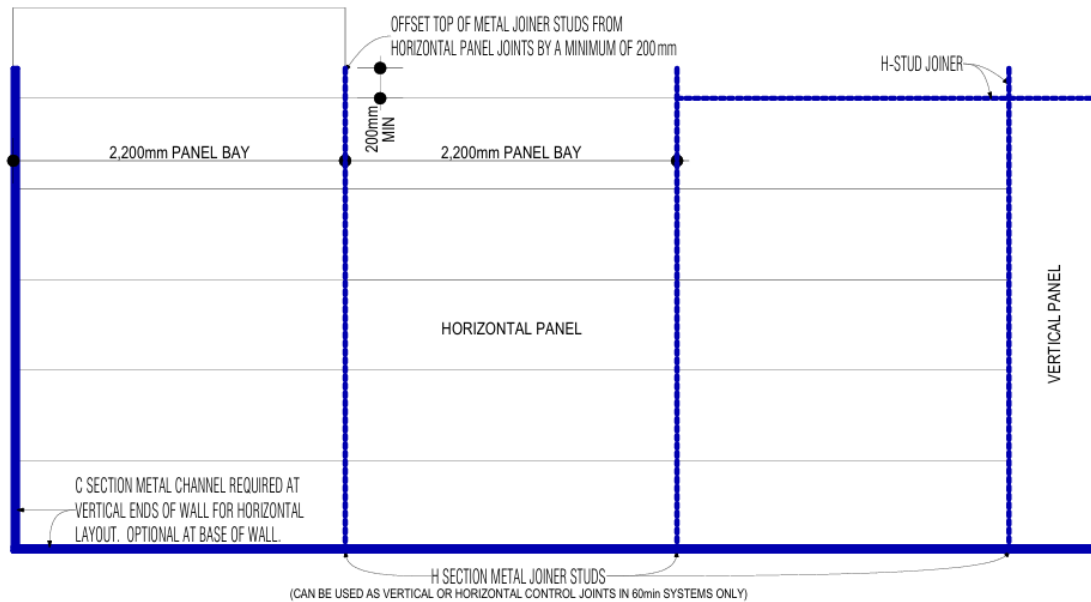

- Equal number of aluminium connections to both sides
- C-Section Metal Channel required at vertical ends of wall, but is optional at base of wall
- H-Section Metal Joiners, used vertically at horizontal panel junctions, and as Vertical and Horizontal Control Joints for 50mm panel party wall systems with an FRL no greater than 60/60/60.
- Base Of Wall – fixed using either a metal base track or Aluminium brackets fixed to both sides of the wall at the base of the panel, typically in each H-Stud and at the horizontal mid span of each H-Stud
- Aluminium brackets are required to be fixed to vertical ends of wall, and the bottom and top of each wall and roof element, into each H-Stud and at the horizontal mid span of each H-Stud
- 3000mm maximum vertical spacings for aluminium brackets permitted when using 3200mm H-Studs, i.e. top of ground floor wall to top of first floor wall. Brackets not required in bottom plate of the first floor wall if the ground floor H-Stud passes the first floor bottom plate.
- Discontinuous Construction – Only permits Aluminium Bracket fixings to the periphery, i.e.
 - The vertical ends of the wall
 - The bottom and top of each wall element at each level
- Discontinuous Construction is not required in the roof space so additional fixing can be used if required.

ONE AAC PANEL – 50MM PARTY WALL DETAIL

FRL 60/60/60 R_w + Ctr 53

50MM AAC PANEL SYSTEMS – UPTO 90 MINUTES FRL

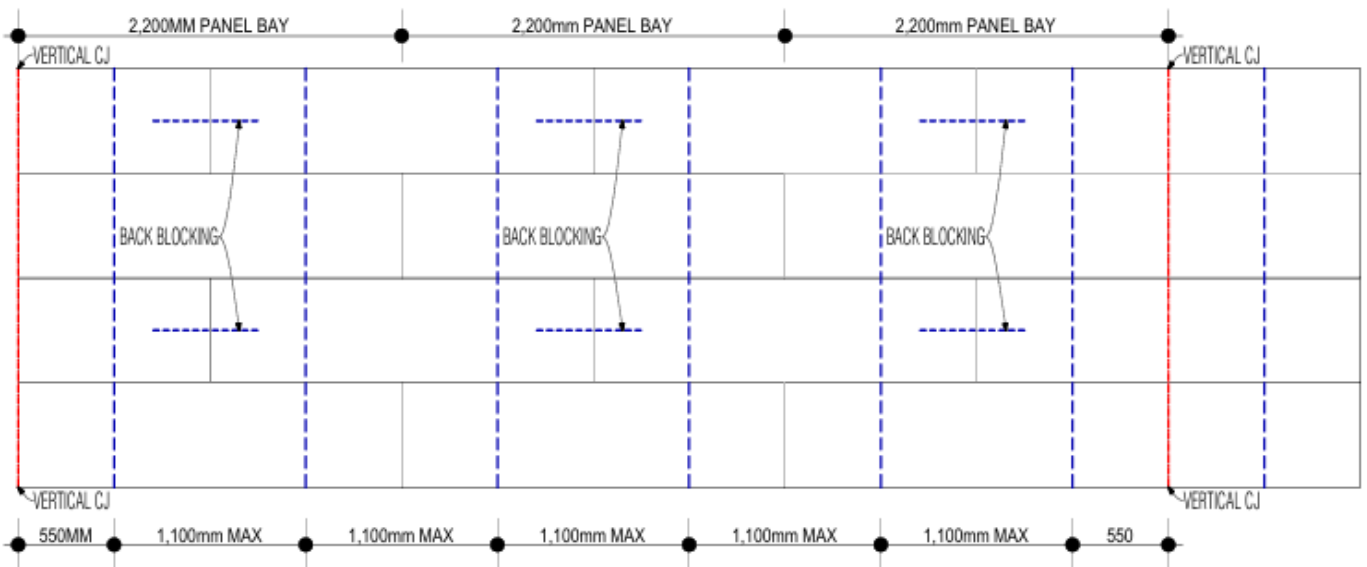
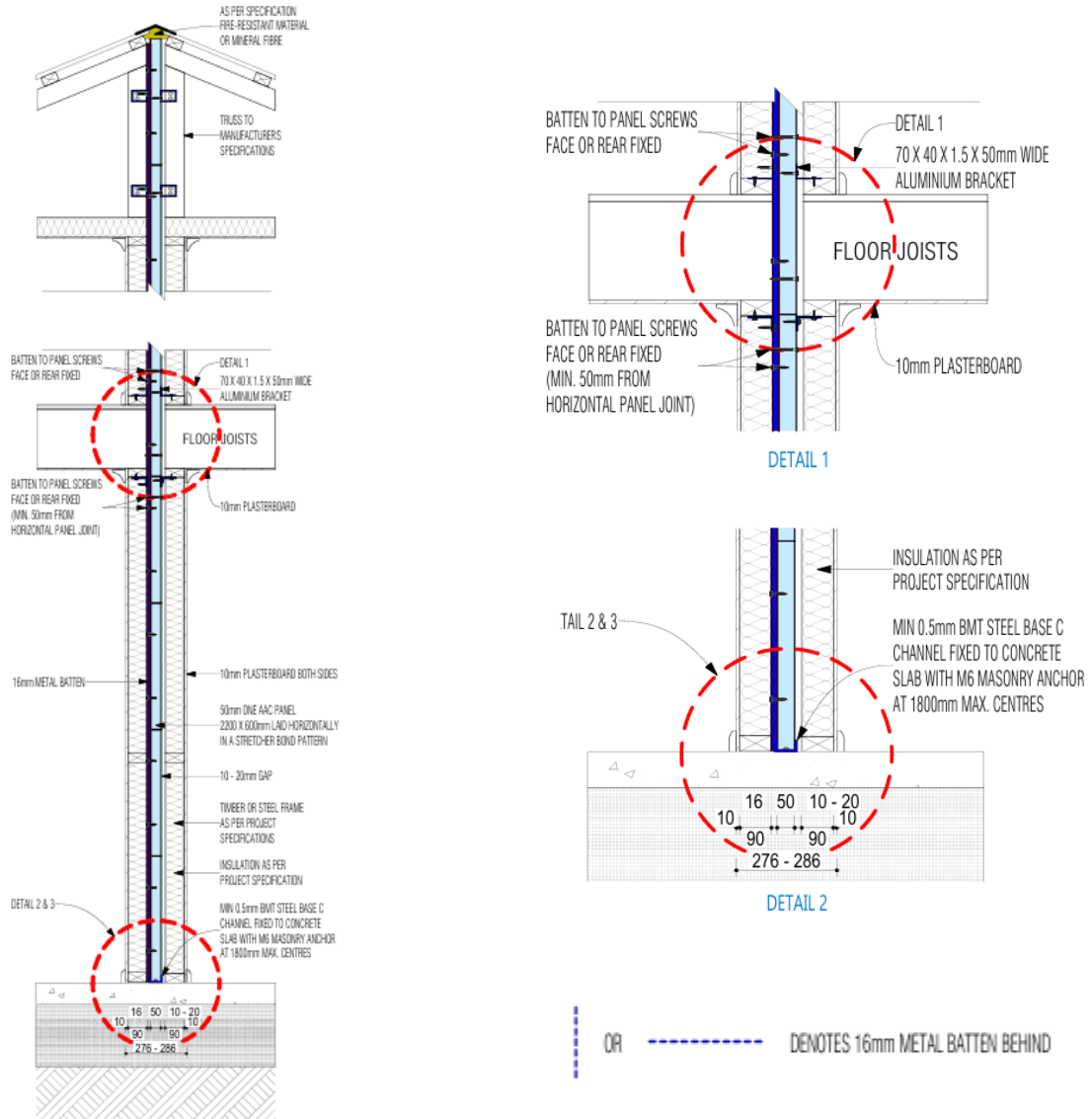

ONE AAC PANEL – 50MM PARTY WALL DETAIL

FRL 90/90/90 Rw + Ctr 53

50MM AAC PANEL SYSTEMS – UPTO 90 MINUTES FRL

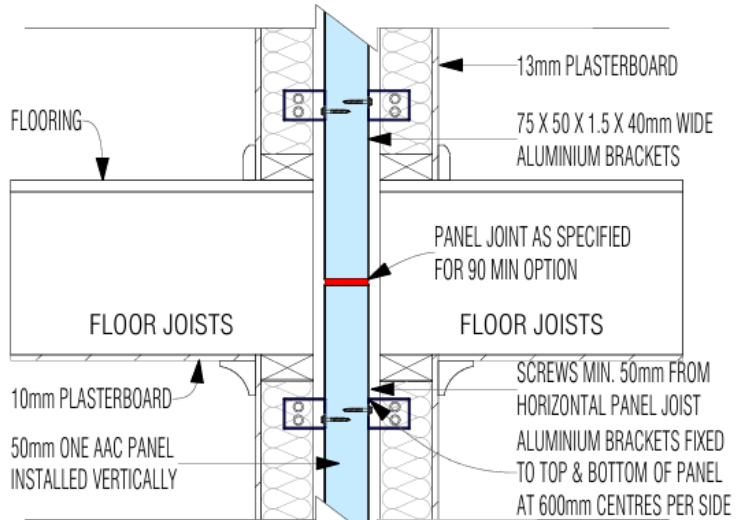
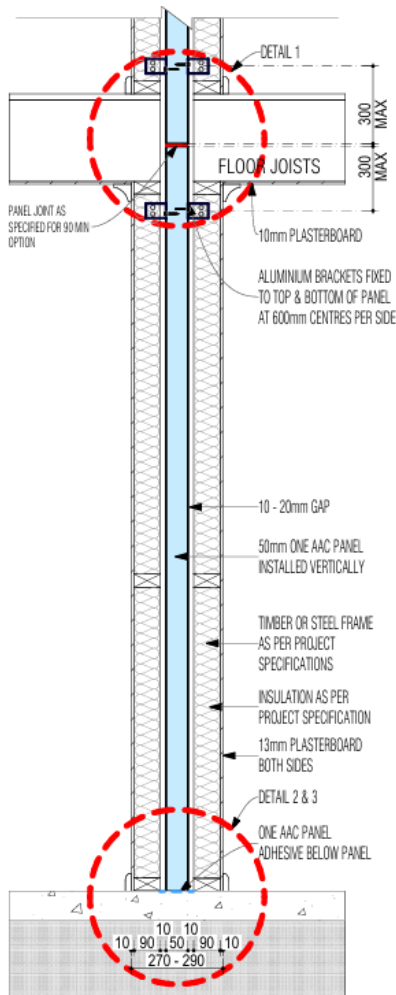
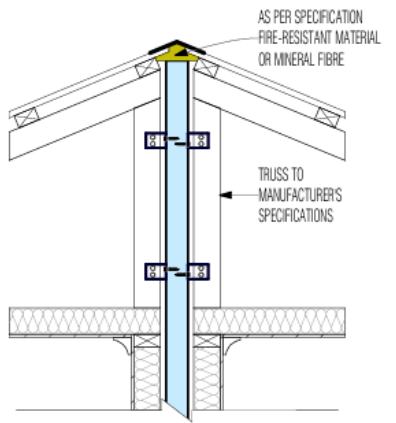

DETAIL 1

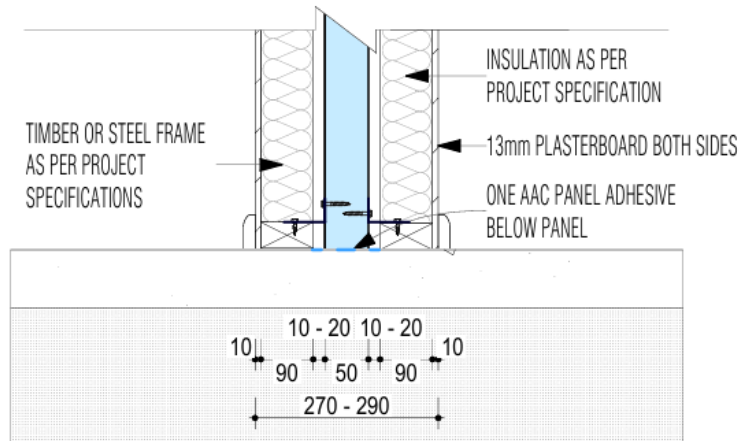

DETAIL 2 - OPTION 1

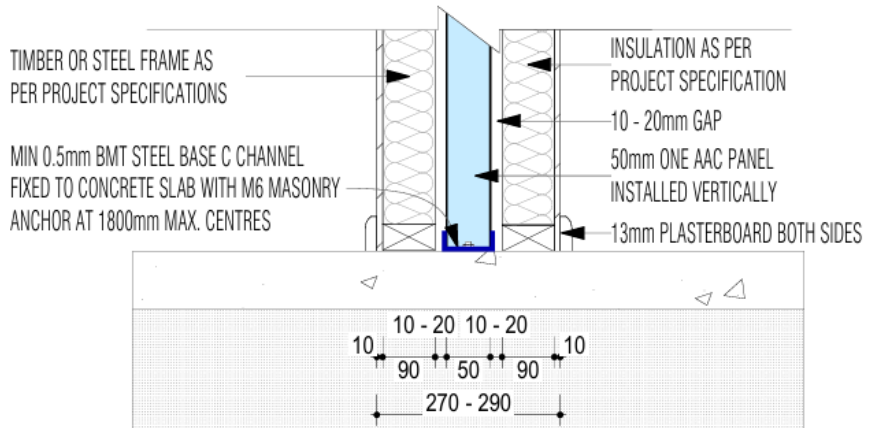

DETAIL 3 - OPTION 2

ONE AAC PANEL – 50MM PARTY WALL DETAIL

FRL 90/90/90 Rw + Ctr 53

75MM AAC PANEL SYSTEMS – UPTO 120 MINUTES FRL

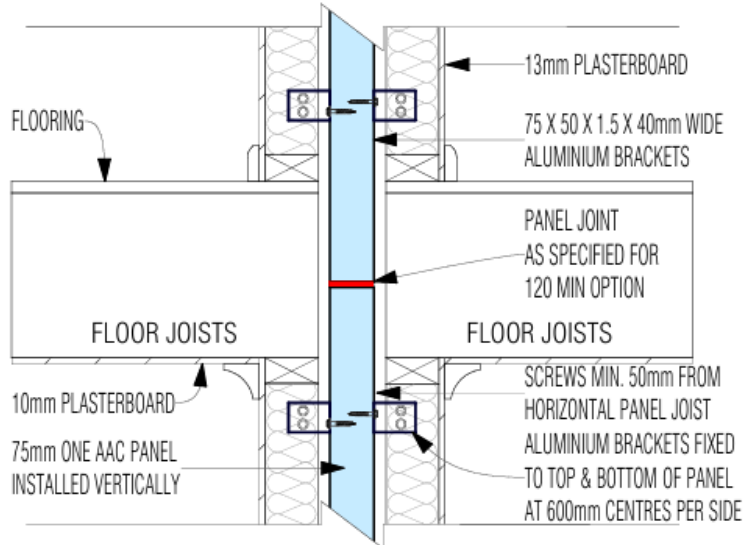
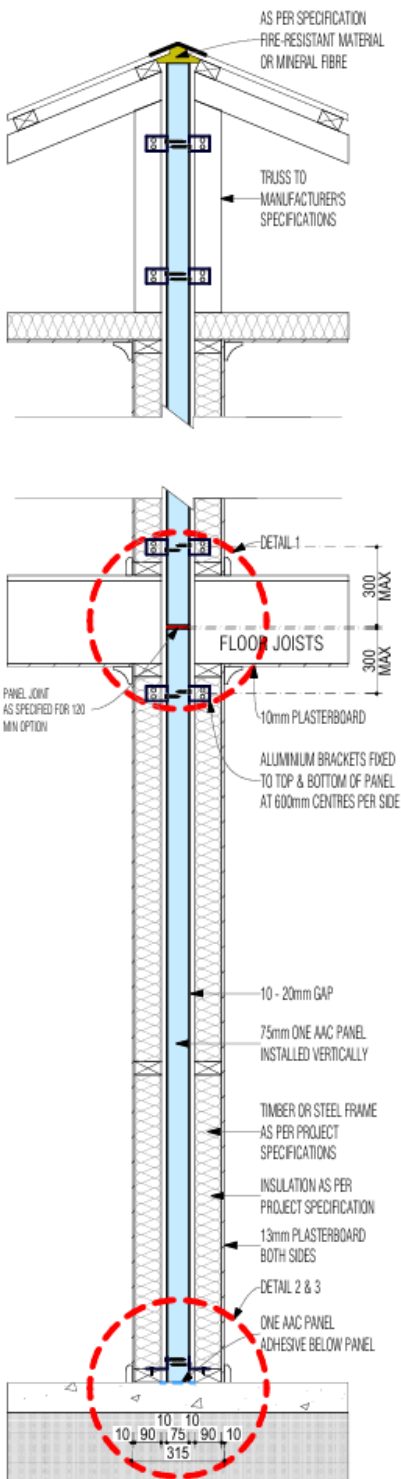

DETAIL 1

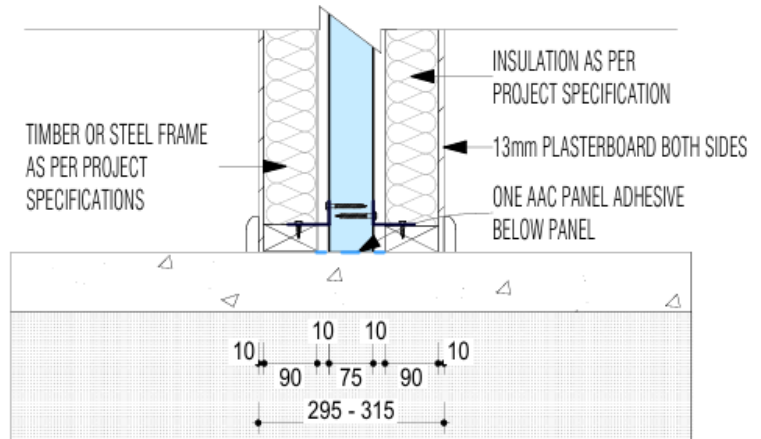

DETAIL 2 - OPTION 1

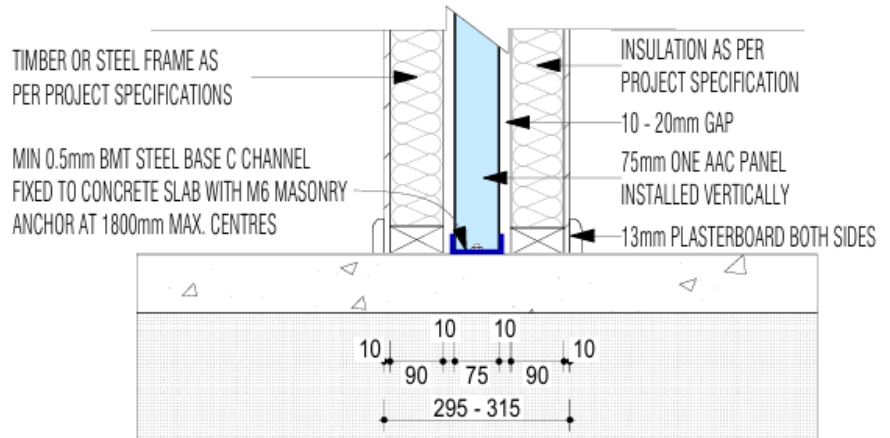

DETAIL 3 - OPTION 2

ONE AAC PANEL – 75MM PARTY WALL DETAIL

FRL 60/60/60 & 90/90/90 & 120/120/120 Rw + Ctr 53

PANEL CONTROL JOINT SPECIFICATION OPTIONS:

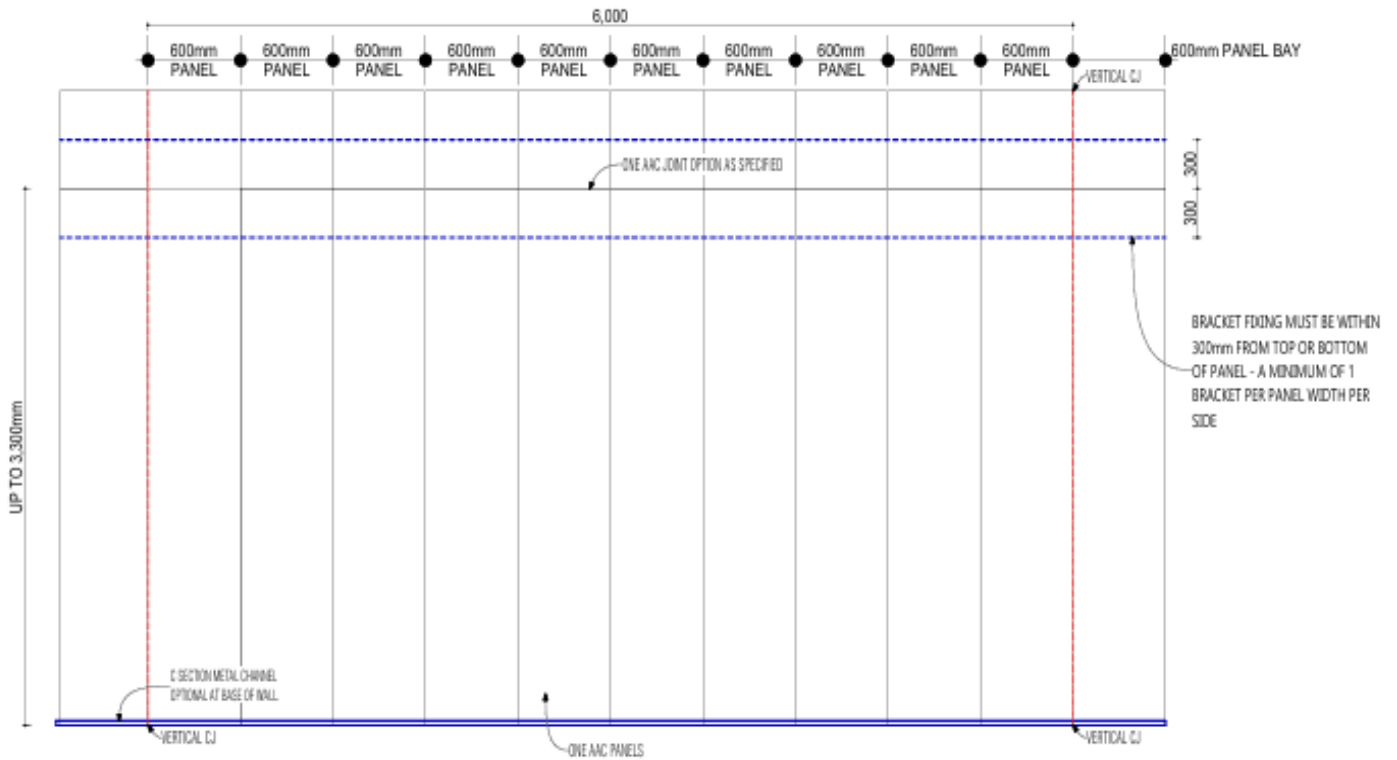

SPECIFICATIONS FOR CONTROL JOINTS WHEN USING 50MM OR 75MM ONE AAC PANEL

FRL	VERTICAL CONTROL JOINTS	HORIZONTAL CONTROL JOINTS
60/60/60	<ul style="list-style-type: none"> • Fire Rated Sealant to one side only and at a Maximum of 6m vertical spacings • H-Stud Joiners at a Maximum of 6m vertical spacings 	<ul style="list-style-type: none"> • ONE AAC Adhesive • H-Stud Joiners • Party Wall Fire Seal Blanket cut into strips equal to or greater than the panel thickness
90/90/90	<ul style="list-style-type: none"> • Fire Rated Sealant to both sides and at a Maximum of 6m vertical spacings 	<ul style="list-style-type: none"> • ONE AAC Adhesive • 13mm Fire Damper Strip cut into strips equal to or greater than the panel thickness
120/120/120	<ul style="list-style-type: none"> • Fire Rated Sealant to both sides and at a Maximum of 6m vertical spacings 	<ul style="list-style-type: none"> • ONE AAC Adhesive • 13mm Fire Damper Strip cut into strips equal to or greater than the panel thickness

PARTY WALL TO EXTERNAL WALL JUNCTION DETAILS

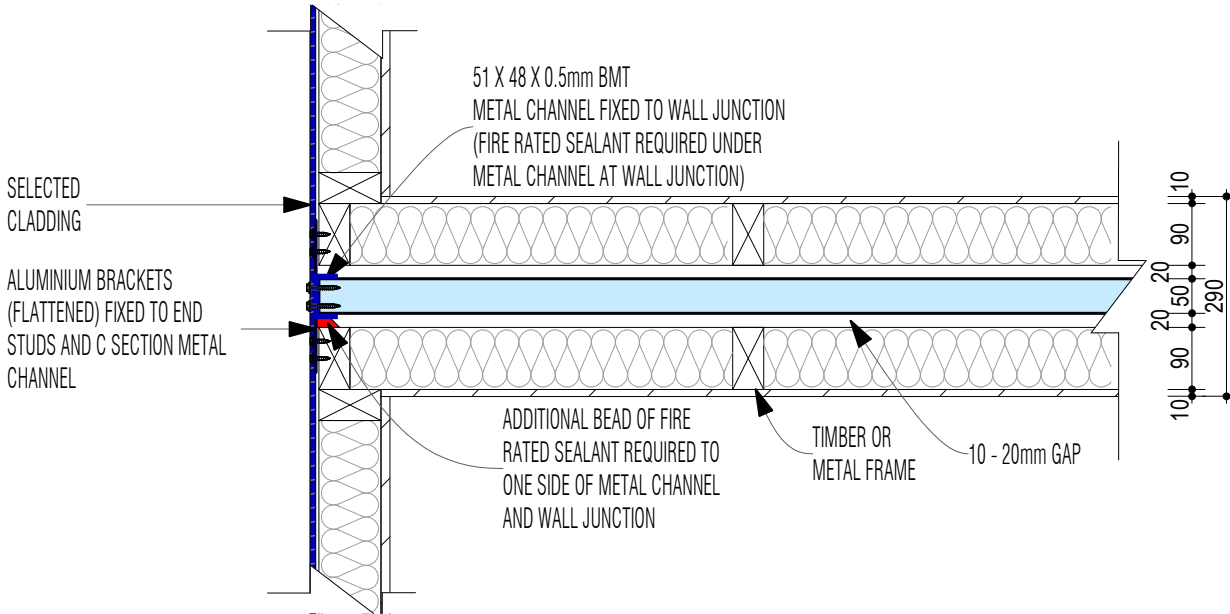

PARTY WALL JUNCTION WITH CLADDING (NO CAVITY OPTION)

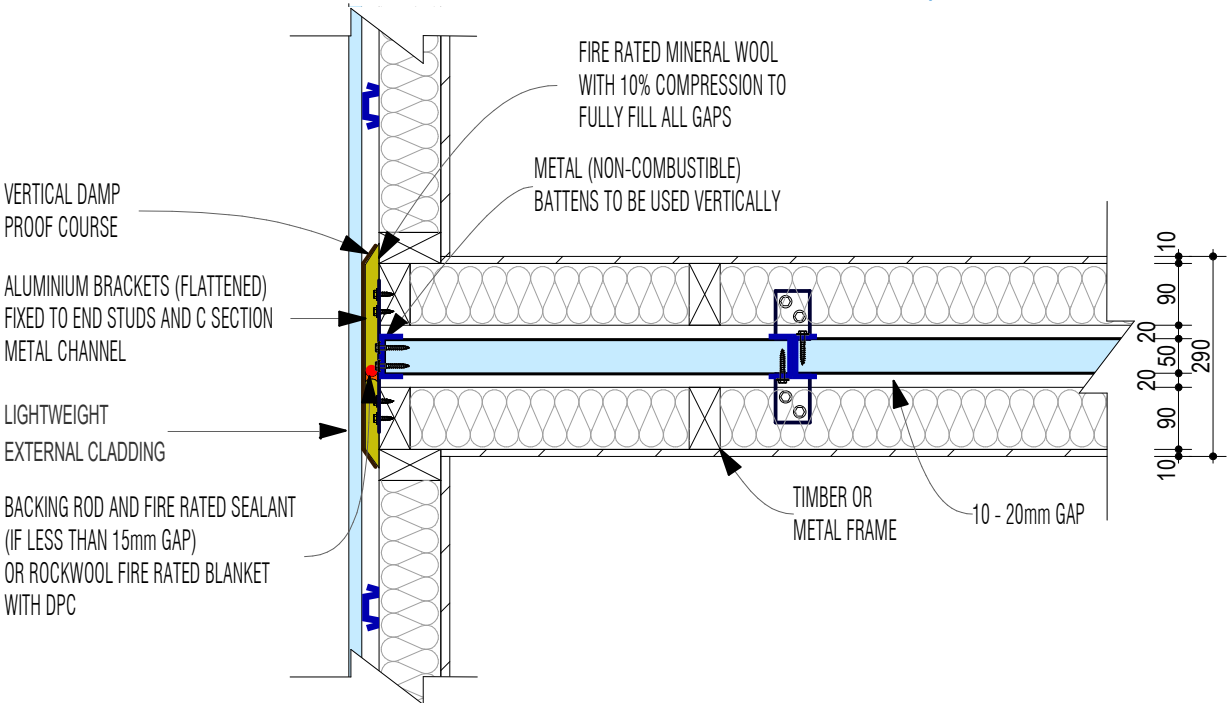

PARTY WALL JUNCTION WITH CLADDING (CAVITY OPTION)

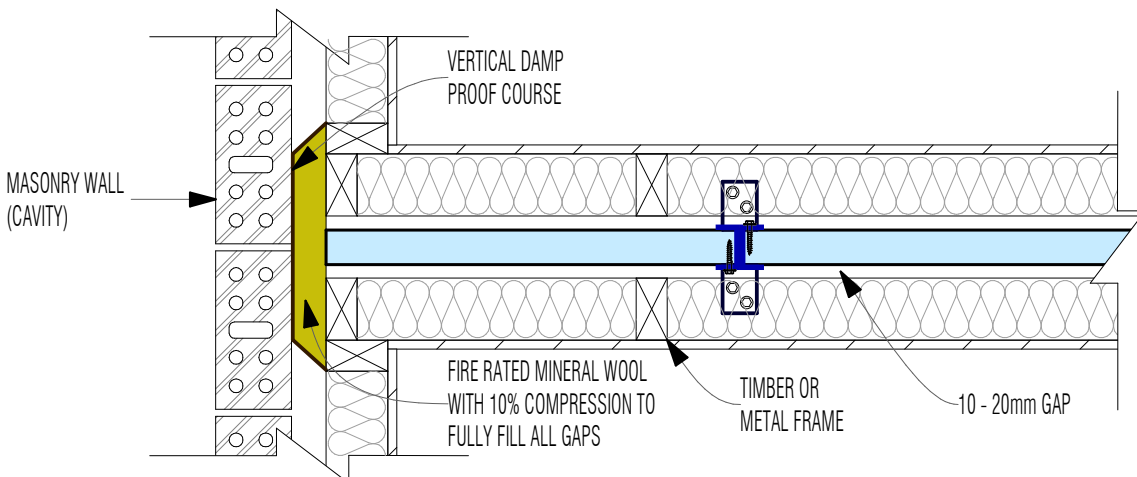

PARTY WALL JUNCTION WITH MASONRY (CAVITY OPTION)

PARTY WALL TO EXTERNAL WALL TRANSITION DETAILS

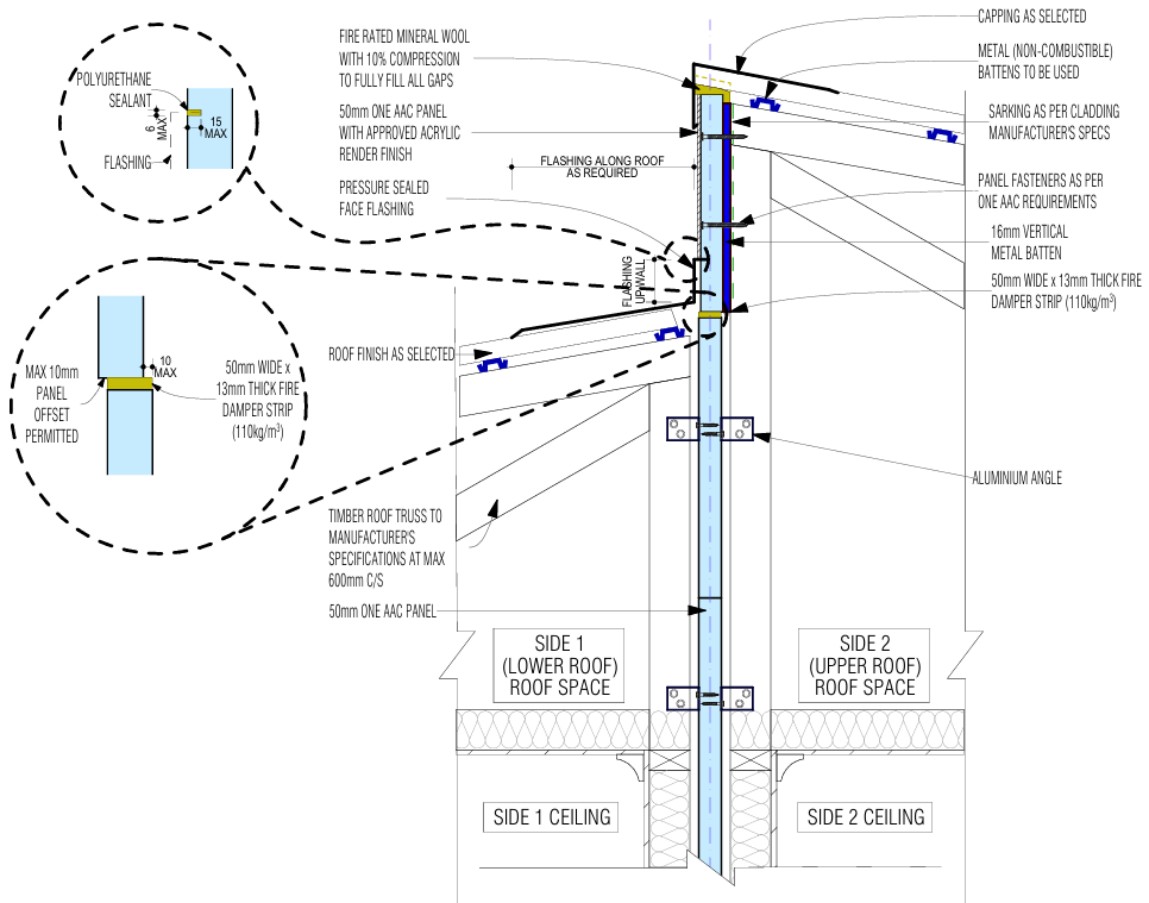

OPTION 1: EXTERNAL WALL PANEL FIXED OVER CAVITY BATTEN ABOVE PARTY WALL

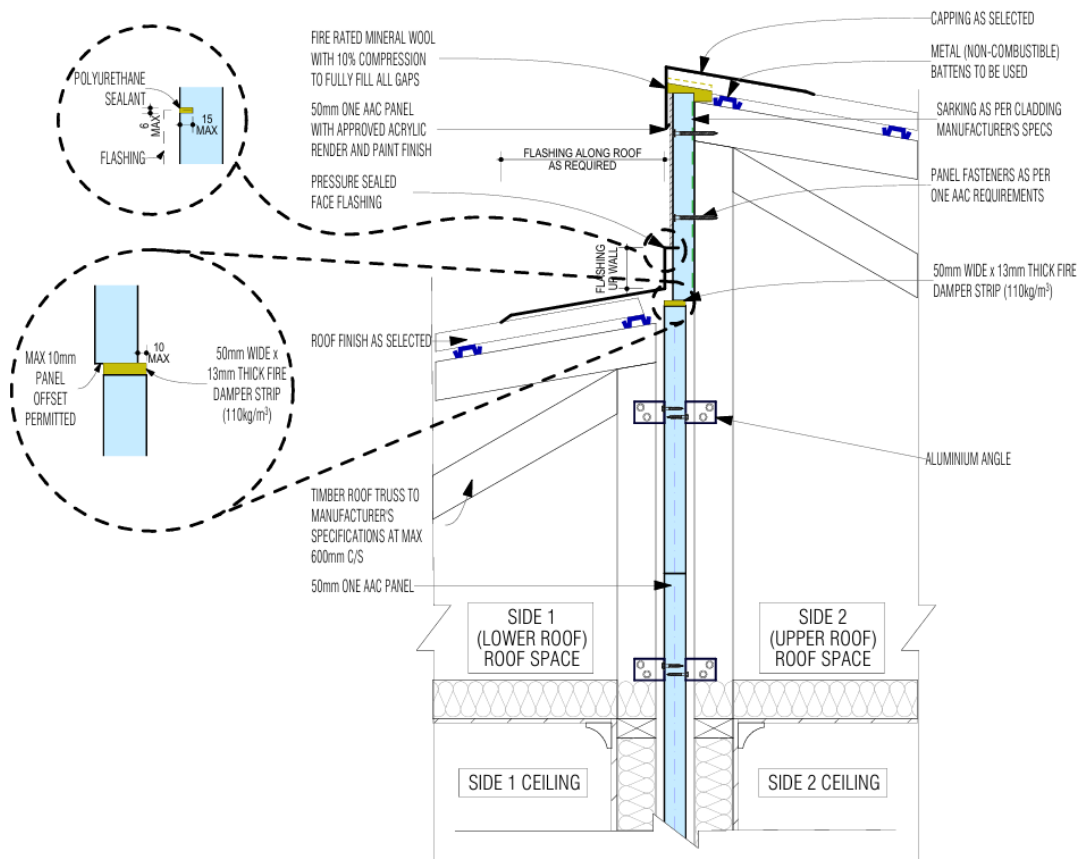

OPTION 2: EXTERNAL WALL PANEL DIRECT FIXED TO FRAME ABOVE PARTY WALL

PARTY WALL TO EXTERNAL WALL TRANSITION DETAILS

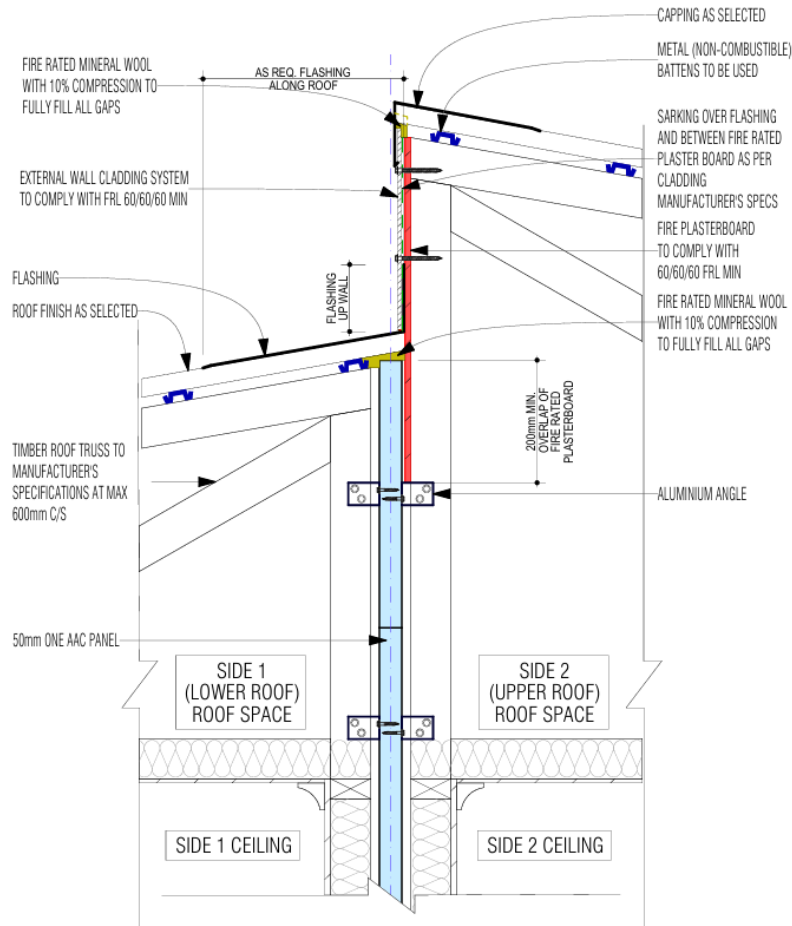

OPTION 3: EXTERNAL WALL CLADDING / PLASTERBOARD ABOVE PARTY WALL

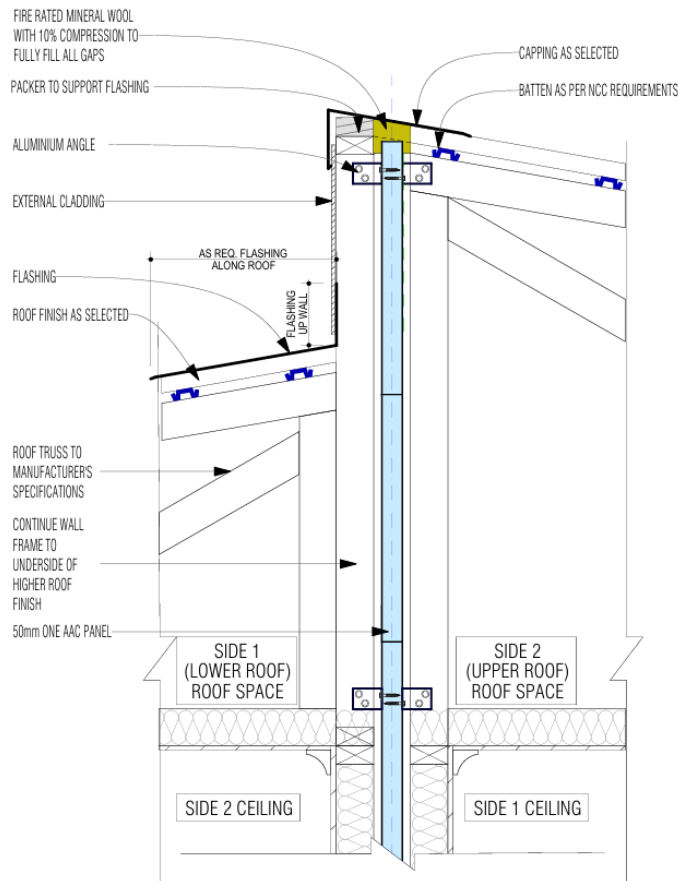

OPTION 4: TWIN WALL FRAME / EXTERNAL WALL / ABOVE PARTY WALL

PARTY WALL CANTERLEVERED PANEL DETAIL

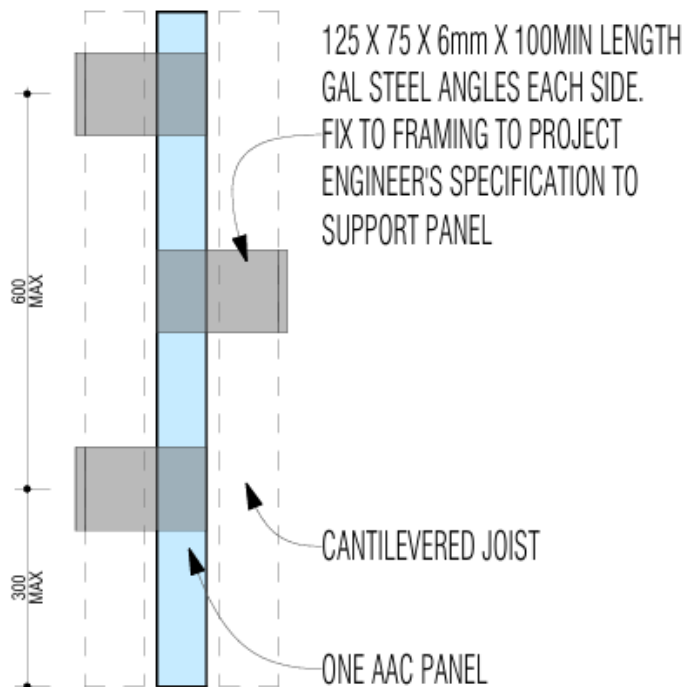
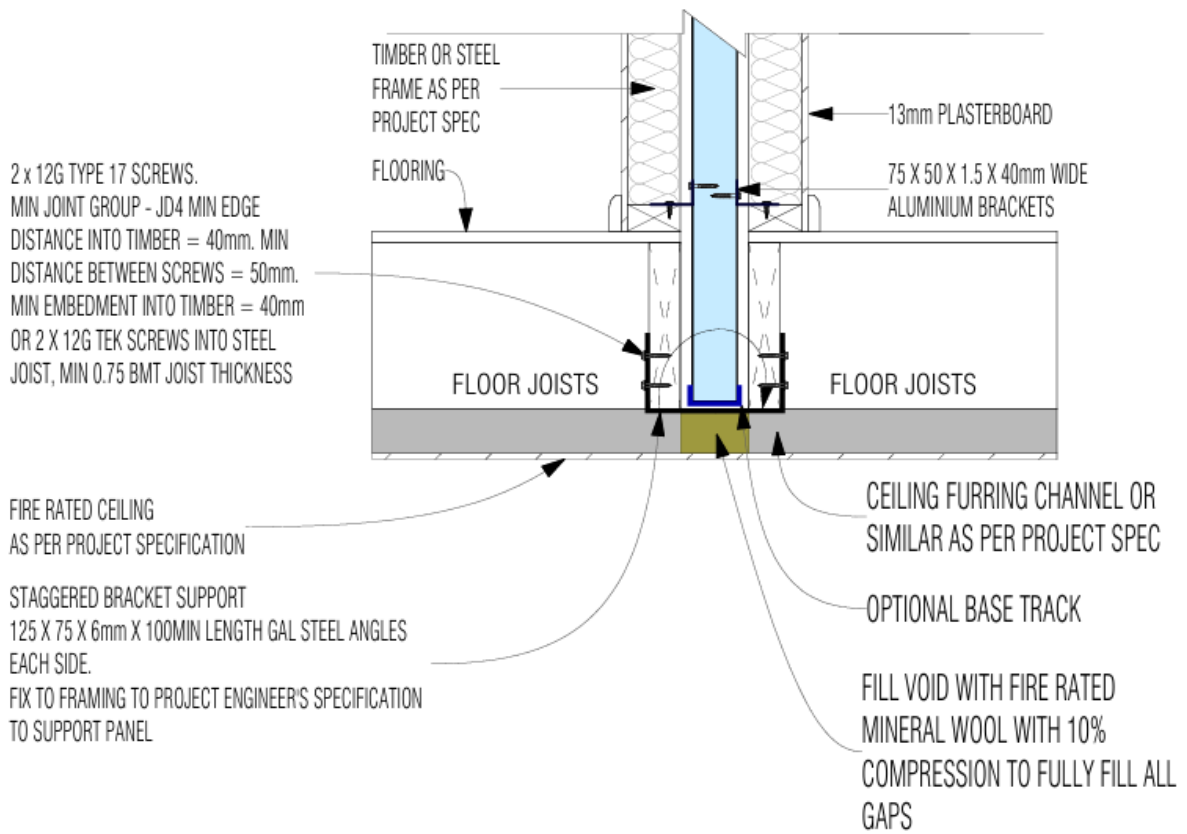

PARTY WALL PANEL PENETRATION DETAIL

NOTE: Penetrations through any fire wall should be avoided as much as possible, but if it can't be helped, then proprietary approved methods such as Fire Rated Sealants, Fire Collars or Fire Penetration Boxes should be used.

All approved methods have been tested with 75mm AAC, so if a penetration in 50mm AAC is required, then the section of the party wall requiring the penetration will need to be doubled up to be able to use the proprietary approved methods such as Fire Rated Sealants, Fire Collars or Fire Penetration Boxes.

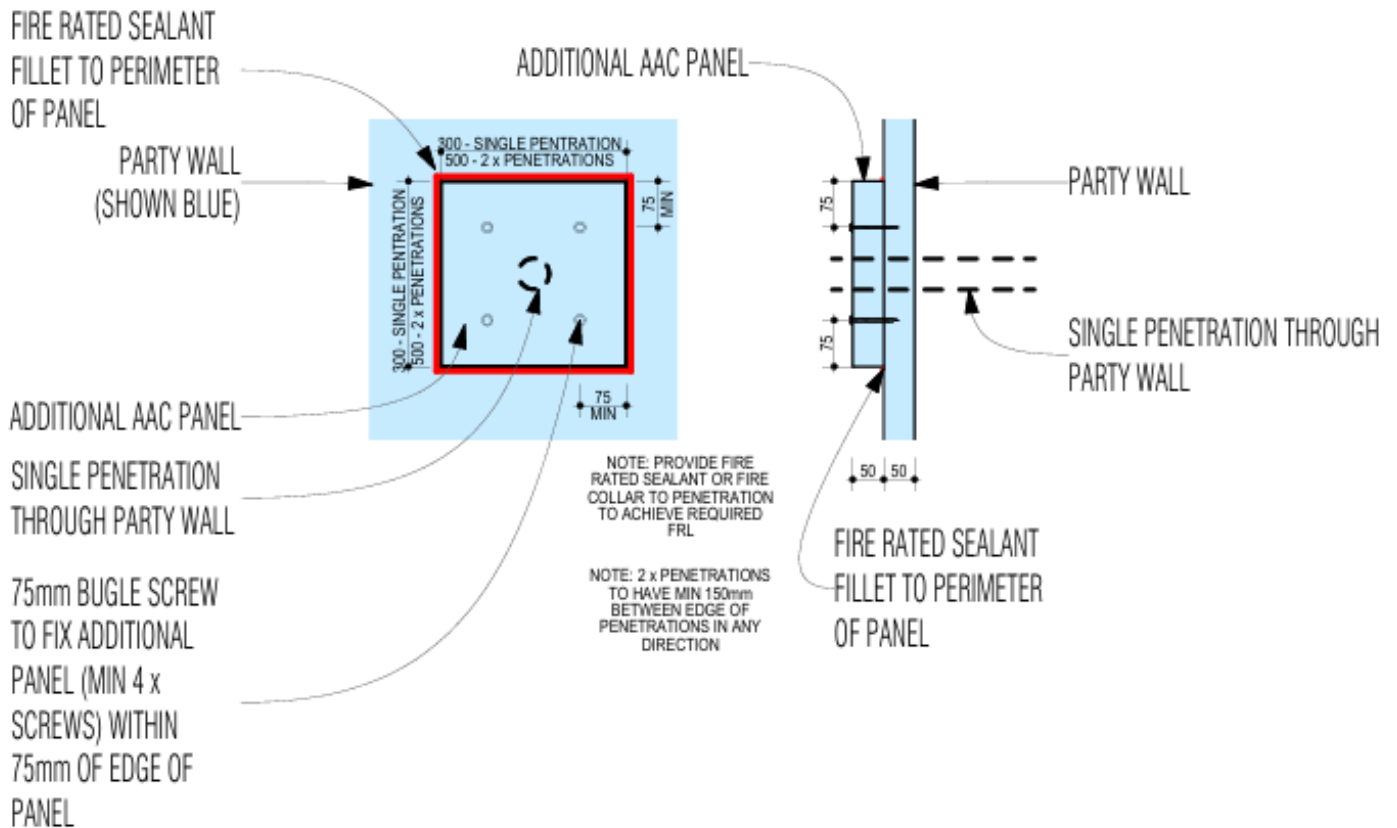



Certificate of Conformity

Certification Body:

Global-Mark Pty Ltd,
Suite 4.07,
32 Delhi Road,
North Ryde NSW
2113, Australia
Ph: +61 2 9886 0222
www.global-mark.com.au

Certificate Holder:

ONE AAC PANEL
485 Campbelltown Rd
Denham Court NSW
2565
Ph: 1300 010 222
www.oneaac.com.au

Certificate number: CM30031 Rev 4**THIS TO CERTIFY THAT****ONE AAC PANEL****Type and/or use of product:**

ONE AAC PANELS are 50mm and 75mm thick reinforced AAC (Autoclaved Aerated Concrete) Panels for use in all building types (BCA Volumes 1 & 2), in the following applications:

- Fire, thermal & acoustic rated cladding for load bearing, External Walls of timber or steel framed wall structures.
- Fire, thermal & acoustic rated cladding for load bearing, Dual Boundary External Walls of timber or steel framed wall structures.
- Fire, thermal & acoustic rated wall system for load bearing, Internal Separating Walls of timber or steel framing between separate occupancies in multi-unit buildings.
- Fire, thermal & acoustic rated Flooring systems for timber or steel framed floor structures.

Description of product:

Reinforced Autoclaved Aerated Concrete (AAC) Panels compliant with AS 5146, in the following sizes:

- 50mm thickness x 600mm width and lengths of 2,200mm, 2,400mm, 2,550mm, 2,700mm, 2,850mm & 3,000mm and
- 75mm thickness x 600mm width and lengths of 1,800mm, 2,200mm, 2,400mm, 2,700mm, 2,850mm, 3,000mm & 3,300mm, and
- Custom length panels (up to the above maximum lengths) are also available in the above thicknesses and widths

COMPLIES WITH THE FOLLOWING BCA PROVISIONS AND STATE OR TERRITORY VARIATION(S)**BCA 2022**

Performance Requirement(s)	Volume One		Volume Two including Housing Provisions	
	B1P1	B1P2	H1P1	H1P2
Structural reliability				Structural stability and resistance to actions
Structural resistance				

Scope of certification: The CodeMark Scheme is a building product certification scheme. The rules of the Scheme are available at the ABCB website www.abcb.gov.au. This Certificate of Conformity is to confirm that the relevant requirements of the Building Code of Australia (BCA) as claimed against have been met. The responsibility for the product performance and its fitness for the intended use remain with the certificate holder. The certification is not transferrable to a manufacturer not listed on Appendix A of this certificate.

Disclaimer: The Scheme Owner, Scheme Administrator and Scheme Accreditation Body do not make any representations, warranties or guarantees, and accept no legal liability whatsoever arising from or connected to, the accuracy, reliability, currency or completeness of any material contained within this certificate; and the Scheme Owner, Scheme Administrator and Scheme Accreditation Body disclaim to the extent permitted by law, all liability (including negligence) for claims of losses, expenses, damages and costs arising as a result of the use of the product(s) referred to in this certificate. The purpose of Global-Mark construction site audits is to confirm the practicability of installing the product; and to confirm the appropriateness and accuracy of installation instructions. In placing the CodeMark mark on the product/system, the certificate holder makes a declaration of compliance with the certification standard(s) and confirms that the product is identical to the product certified herein. In issuing this Certificate of Approval Global-Mark has relied on the expertise of external bodies (laboratories, and technical experts).

Herve Michoux
Global-Mark Managing Director

Peter Gardner
Unrestricted Building Certifier

Date of issue: 23/06/2025**Date of expiry: 17/05/2028**

Certificate number: CM30031 Rev 4

This certificate is only valid when reproduced in its entirety.

Page 1 of 13

F3P1	Weatherproofing	H2P2	Weatherproofing
Deemed-to-Satisfy Provision(s):			
B1D4 (b)(ii)	Determination of structural resistance of materials and forms of construction	H1D7 (4)(a)	Wall cladding
C2D2	Fire resistance and stability – Type of construction required	H3D3	Fire Separation of external walls
Specification 1	Fire-resistance of building elements	Specification 1	Fire-resistance of building elements
Specification 5	Fire resisting construction	HP 9.2.3	Construction of external walls
C2D10	Non-combustible material		
		HP 9.3.1	Fire Protection of separating walls
		HP 9.3.4	Fire Protection – Horizontal projections
		HP 9.4.1	Fire Protection of garage top dwellings - Walls
F7D3	Determination of airborne sound insulation ratings	HP 10.7.1	Sound insulation requirements
F7D4	Determination of impact sound insulation ratings	HP 10.7.2	Determination of airborne sound insulation ratings
F7D5	Sound insulation rating of floors	HP 10.7.3	Construction of sound insulated walls
F7D6	Sound insulation rating of walls		
F8D3	Condensation management	H4D9	Condensation management
G5D3	Construction in bushfire prone areas – Protection of residential buildings	H7D4 (2)	Construction in bushfire prone areas
G5D4	Construction in bushfire prone areas – Protection of certain Class 9 buildings		
J3D8	External walls of a sole occupancy unit of a Class 2 building or Class 4 part of a building		
J4D6	Building fabric – Walls and glazing	HP 13.2.5	Building fabric – External walls
State or territory variation(s):			
NT B1D4 (b)(ii)	Structural resistance		
QLD B1D4 (b)(ii)	Structural resistance		
WA B1D4 (b)(ii)	Structural resistance	WA H1D7 (4)(a)	Wall cladding
		HP NSW 9.4.1	Fire Protection of garage top dwellings – Walls
		HP NSW 9.4.3	Fire Protection of garage top dwellings – Separating floors

NT Part F7	Sound transmission & insulation	HP NT 10.7	Sound insulation
		TAS H4D9	Condensation management
NSW G5D3	Construction in bushfire prone areas – Protection of residential buildings	NSW H7D4 (2)	Construction in bushfire prone areas
NSW G5D4	Construction in bushfire prone areas – Protection of certain Class 9 buildings		
VIC G5D4	Construction in bushfire prone areas – Protection of certain Class 9 buildings		
NSW J3D8	External walls of a sole occupancy unit of a Class 2 building or Class 4 part of a building		
NSW J4D6	Building fabric – Walls and glazing	HP NSW 13.2.5	Energy efficiency – External walls
NSW Section J	Energy efficiency: Class 2 or Class 4 part of a building (up to V3 BASIX dwellings & BASIX Alterations and additions) – NCC 2019 A1 NSW Section J Class 2 or Class 4 part of a building (V4 or later BASIX dwellings) plus Class 3, 5, 6, 7, 8 & 9 buildings – NCC 2022 Section J	NSW Part H6	Energy efficiency: Up to V3 BASIX dwellings & BASIX Alterations and additions – NCC 2019 A1 NSW 2.6 V4 or later BASIX dwellings – NCC 2022 NSW Part H6
		NT Part H6	Energy efficiency
		HP NT 13.2.5	Energy efficiency building fabric – External walls
TAS Part J3	Elemental provisions for a sole-occupancy unit of a Class 2 building or a Class 4 part of a building	TAS Part H6	Energy efficiency – NCC 2019 (A1) 2.6
		HP TAS 13.2	Energy efficiency – NCC 2019 3.12

SUBJECT TO THE FOLLOWING LIMITATIONS AND CONDITIONS AND THE PRODUCT TECHNICAL DATA IN APPENDIX A AND EVALUATION STATEMENTS IN APPENDIX B	
Limitations and conditions:	Building classification/s:
<p>Volume 1 – B1P1, B1P2, B1D4 & Volume 2 – H1P1, H1D7 Volume 1 – NT B1D4, QLD B1D4, WA B1D4 & Volume 2 – WA H1D7</p> <p>External and Zero Boundary wall systems have maximum design wind pressure limits documented within the relevant ONE AAC Design & Installation Manuals (for External Walls and/or Dual Boundary Walls – refer Appendix B2). Wind pressures (as determined by AS4055 or AS/NZS1170.2), construction details and fixing methods must follow the relevant details contained within the engineering detail sections of the relevant ONE AAC Design & Installation Manuals for External Walls and/or Dual Boundary Walls, refer Appendix B2.</p> <p>Supporting stud frame design & certification shall be conducted by a suitably qualified engineer in accordance with AS 1684 “Timber Framing Code” for Timber framing and NASH Standard or AS/NZS 4600 “Cold-formed steel structures”, for Steel framing.</p>	1, 2, 3, 4, 5, 6, 7, 8, 9 & 10
<p>Volume 1 – B1P1 (2)(e), (f) & (i) & Volume 2 – H1P1 (2)(e), (f) & (i)</p> <p>Snow, liquid pressure and earth pressure actions are excluded.</p>	1, 2, 3, 4, 5, 6, 7, 8, 9 & 10
<p>Volume 1 – B1P4 & Volume 2 – H1P2</p> <p>Compliance for flood hazard areas is excluded.</p>	1, 2, 3, 4, 5, 6, 7, 8, 9 & 10
<p>Volume 1 – C2D2, Specification 1 & Specification 5 & Volume 2 – H3D3 & Specification 1 Housing Provisions – 9.2.3, 9.3.1, 9.3.4, 9.4.1 & HP NSW 9.4.1 & HP NSW 9.4.3</p> <p>Refer to relevant construction options, details & conditions included in the relevant ONE AAC Design & Installation Manuals, refer Appendix B2:</p> <ul style="list-style-type: none"> • ONE AAC External wall FRLs (for External and Internal fire sources) up to 120/120/120 are achievable (refer construction system options in the External Wall Manual) • ONE AAC Intertency wall FRLs of 60/60/60, 90/90/90 or 120/120/120 are achievable (refer construction system options in the Party Wall Manual) • ONE AAC Dual Boundary wall FRLs of 60/60/60 apply (refer construction system options in the Dual Boundary Wall Manual) • ONE AAC Floor Systems using 75mm thick AAC panels achieve FRLs up to 90/90/90 for fire sources above and below when a Ceiling system using 2 x 16mm or 3 x 13mm Gyprock Fyrchek plasterboard is directly fixed to joists or furring channels (minimum 28mm x 35mm x 0.5mm BMT) at spacing of 600mm max • For additional FRLs refer to construction system options in Appendix A3 & the relevant Wall or Floor System Manuals, refer Appendix B2. 	1, 2, 3, 4, 5, 6, 7, 8, 9 & 10
<p>Volume 1 – C2D10</p> <p>Non-combustibility relates to AAC material only. Certification is based on the system being installed using components & accessories as detailed in the relevant ONE AAC Design & Installation Manuals, refer Appendix B2. Substitution of wall system components &/or accessories may be permitted, the general performance specifications of components &/or accessories must be maintained for this certificate to remain valid.</p>	2, 3, 4, 5, 6, 7, 8 & 9
<p>Volume 1 – C2D10 (1)(a)</p> <p>In a building required to be of Type A or B construction, construction elements and their components must be non-combustible for all external walls, common walls and non-loadbearing internal walls that are required to be fire-resisting, timber framing and components may not be used.</p>	2, 3, 4, 5, 6, 7, 8 & 9

<p>Volume 1 – C2D10 (6) In external wall applications, flexible sarking membrane (wall wrap) materials shall be installed in accordance with the ONE AAC Design & Installation Manual for External Walls, refer Appendix B2.</p>	<p>2, 3, 4, 5, 6, 7, 8 & 9</p>
<p>Volume 1 – F3P1 ONE AAC External walls & Zero Boundary walls are considered to remain Weatherproof, when the external wall:</p> <ol style="list-style-type: none"> has a risk score of 20 or less, when the sum of all risk factor scores are determined in accordance with Tables F3V1a or H2V1a, and is subject to Ultimate Limit State (ULS) wind pressures not exceeding ±2.5 kPa, and deflections of the supporting structures are limited to Span/250 for the Serviceability Limit State (SLS) wind pressures, and include only windows that comply with AS 2047, and design & installation complies with the ONE AAC External wall or Zero Boundary wall design & installation manuals, refer Appendix B2. 	<p>1, 2, 3, 4, 5, 6, 7, 8, 9 & 10</p>
<p>Volume 1 – G5D3 In designated Bushfire prone areas, when the building is constructed in accordance with AS3959:2018 including Amendments 1 & 2, or NASH Standard – Steel Framed Construction in Bushfire Areas (where applicable), ONE AAC Panels are permitted for use as external wall cladding in buildings subject to Bushfire Attack Level in all zones up to and including BAL-FZ.</p> <p>Volume 2 – H7D4 In Queensland (per QLD G5D2 & QLD H7D4(3)), areas where the classified vegetation is Group F rainforest (excluding wet sclerophyll forest types), mangrove communities and grasslands under 300mm high, are excluded.</p>	<p>Class 1, 2 & 3 buildings & 10a buildings or decks immediately adjacent or connected to such buildings</p>
<p>Volume 1 – G5D4 In designated Bushfire prone areas, when the building is constructed in accordance with Specification 43, ONE AAC Panels are permitted for use as external wall cladding in buildings subject to Bushfire Attack Level not exceeding BAL-12.5. Construction in BAL-19, BAL-29, BAL-40 & BAL-FZ are outside the scope of application of the clause.</p>	<p>Class 9a, 9b & 9c buildings & Class 10a buildings or decks immediately adjacent or connected to such buildings</p>
<p>Volume 1 – J3D8 Volume 1 – NSW J3D8 & TAS Part J3 The wall system contributes towards the Total wall system U or R value, which is to be determined in accordance with Volume 1 – J3D8 (2) & J3D9 or specific state variation. Insulation shall be included within the wall system, as outlined in the relevant Design & Installation Manual & according to project specifications.</p>	<p>Class 2 building or Class 4 part of a building</p>
<p>Volume 1 – J4D6 Volume 1 – NSW J4D6 The wall system contributes towards the Total wall system U or R value, which is to be determined in accordance with Volume 1 – J4D6 & Housing Provisions – 13.2.5 or specific state variation. Insulation shall be included within the wall system, as outlined in the relevant Design & Installation Manual & according to project specifications.</p>	<p>Class 1, 3, 5, 6, 7, 8, 9 & 10 buildings</p>
<p>Volume 1 – NSW G5D3 ONE AAC Panels are permitted for use as external wall cladding in designated bushfire prone areas, subject to Bushfire Attack Level up to and including BAL-29, determined in accordance with Planning for Bush Fire Protection 2019 including addendum November 2022, when the building is constructed in accordance with:</p> <ul style="list-style-type: none"> AS3959: 2018 including Amendments 1 & 2, except as modified by Planning for Bush Fire Protection 2019 including addendum November 2022, or where applicable. 	<p>Class 1, 2 & 3 buildings, Class 4 part of a building & Class 10a buildings or decks immediately adjacent or connected to such buildings</p>



Certificate of Conformity

	<ul style="list-style-type: none"> NASH Standard – Steel Framed Construction in Bushfire Areas, except as modified by Planning for Bush Fire Protection 2019 including addendum November 2022. <p>Except as modified by Planning for Bush Fire Protection 2019 including addendum November 2022.</p> <p>The compliance assessment of the certified system is limited to sections 7.5 and 8.3.2 of Planning for Bush Fire Protection 2019 including addendum November 2022.</p> <p>Site specific conditions have not been considered for the compliance assessment, these may include:</p> <ul style="list-style-type: none"> the development consent following consultation with the NSW Rural Fire Service under section 4.14 of the Environmental Planning and Assessment Act 1979 if required, or the development consent with a bushfire safety authority issued under section 100B of the Rural Fires Act 1997 for the purposes of integrated development <p>Planning for Bush Fire Protection 2019 including addendum November 2022 requires a performance-based application in bushfire prone areas subject to Bushfire Attack BAL-40 and BAL-FZ. Construction in NSW's bushfire prone areas subject to Bushfire Attack BAL-40 and BAL-FZ have not been considered in this assessment.</p>	
<p>Volume 1 – NSW G5D4</p> <p>In designated bushfire prone areas subject to Bushfire Attack Levels not exceeding BAL-12.5, determined in accordance with Planning for Bush Fire Protection including addendum November 2022, ONE AAC Panels are permitted for use as external wall cladding, when the building is constructed in accordance with:</p> <ol style="list-style-type: none"> For class 9 buildings, Specification 43 except as modified by Planning for Bush Fire Protection 2019 including addendum November 2022, or For class 10a buildings or decks AS3959: 2018 including Amendment 1 & 2 except as modified by Planning for Bush Fire Protection 2019 including addendum November 2022 and S43C13 <p>The compliance assessment of the certified system is limited to sections 7.5 and 8.3.2 of Planning for Bush Fire Protection 2019 including addendum November 2022.</p> <p>Site specific conditions arising from the development consent with a bushfire safety authority issued under section 100B of the Rural Fires Act 1997 for the purposes of integrated development are site specific and have not been considered for the compliance assessment.</p> <p>Construction in NSW in BAL-19, BAL-29, BAL-40 & BAL-FZ are outside the scope of application of the clause.</p>		<p>Class 9 buildings that have a special fire protection purpose & Class 10a buildings or decks immediately adjacent or connected to such buildings</p>
<p>Volume 1 – VIC G5D4</p> <p>In designated Bushfire prone areas subject to Bushfire Attack Level not exceeding BAL-12.5, ONE AAC Panels are permitted for use as external wall cladding, when the building is constructed in accordance with Specification 43.</p> <p>Construction in VIC in BAL-19, BAL-29, BAL-40 & BAL-FZ are outside the scope of application of the clause.</p>		<p>Class 9a, 9b & 9c buildings & Class 4 part of a building associated with such buildings, plus Class 10a buildings or decks immediately adjacent or connected to such buildings</p> <p>1, 2, 3, 4, 5, 6, 7, 8, 9 & 10</p>
<p>General</p> <p>The supporting structures including stud frame & cavity sub framing, plus internal linings shall be designed & specified by a suitably qualified design professional in accordance with manufacturer guidelines and installed by suitably qualified and trained building professionals, in accordance with manufacturer guidelines and the relevant ONE AAC Design and Installation Manuals, refer Appendix B2.</p>		

A1 Type and intended use of product

Refer to page 1 of this certificate.

A2 Description of product





Refer to page 1 of this certificate.

A3 Product specification

Property	50MM PANELS		75MM XL PANELS	
	Value	Units	Value	Units
Ambient ¹ Density, ρ_{amb} (10% Moisture Content)	561	kg/m ³	440	kg/m ³
Dry ² Density, ρ_{dry}	510	kg/m ³	400	kg/m ³
Working ³ Density, ρ_{work} (10% Moisture Content)	689	kg/m ³	540	kg/m ³
Characteristic Compressive Strength of AAC f _m	2.8	MPa	2.38	MPa
Average Compressive Strength of AAC	3.2	MPa	2.8	MPa
Characteristic Modulus of Rupture, f _{ut}	0.6	MPa	0.4	MPa
Design Ultimate Limit State Bending Capacity, ϕM	0.12	kNm	0.25	kNm
Design Serviceability Limit State Deflection Limit, δ_{sdl}	$l/400$		$l/400$	
Coefficient of contraction	0.4	mm/m	0.4	mm/m
Coefficient of thermal expansion	10	$\times 10^{-6}/^{\circ}C$	10	$\times 10^{-6}/^{\circ}C$

APPENDIX A – PRODUCT TECHNICAL DATA

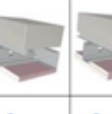
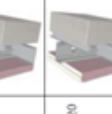
ONE AAC External Walls & Intertency Walls achieve various FRL's and Acoustic ratings as per the following extracts from the Technical Literature:

ONE AAC – External Wall FRLs					ONE AAC – Intertency Wall FRLs and Acoustic Performance				
EXTERNAL PANEL	INTERNAL PLASTERBOARD LINING	FRL OUTSIDE	FRL INSIDE	IMAGE	SYSTEM	PANEL	CONSTRUCTION TYPE	FRL	Rw+Ctr
50mm Or 75mm	10mm – 13mm Standard Plasterboard	120/120/90	-/-/-		1 – 60 LB Stack Bond & Vertical H-Stud	50mm	Framed: Timber or Steel Frame	60/60/60	53
50mm Or 75mm	1 X 13mm Fire Rated Plasterboard	120/120/120	-/60/60		1S – 60 NLB Stack Bond & Vertical H-Stud	50mm	Slab to Slab: Timber or Steel frame infill	-/60/60	53
50mm Or 75mm	1 X 16mm Fire Rated Plasterboard	120/120/120	60/60/60		2 – 90 LB (H-Stud Not Permitted) Stretcher & Vertical	50mm	Framed: Timber or Steel Frame	90/90/90	53
50mm Or 75mm	2 X 13mm Fire Rated Plasterboard	120/120/120	90/90/90		2S – 90 NLB (H-Stud Not Permitted) Stretcher & Vertical	50mm	Slab to Slab: Timber or Steel frame infill	-/90/90	53
50mm Or 75mm	2 X 16mm Fire Rated Plasterboard	120/120/120	120/120/120		3 – 120 LB Vertical Panel	75mm	Framed: Timber or Steel Frame	120/120/120	55
50mm Or 75mm	2 X 16mm Fire Rated Plasterboard	120/120/120	120/120/120		3S – 120 NLB Vertical Panel	75mm	Slab to Slab: Timber or Steel frame infill	-/120/120	55

ONE AAC External Walls achieve Thermal Performance (R values) as per the following extracts from the Technical Literature:

ONE AAC External Walls on 70mm (nom) Stud Frames

ONE AAC SYSTEM	System details – 70mm Frames The following Systems are all based on 50mm/75mm ONE AAC Panel, 20-40mm Cavity, 70mm Frame Thickness, and 10mm Plasterboard internal linings	Total R Value m ² K/W	
		Summer 50mm/75mm	Winter 50mm/75mm
NS-1-70	Panel + Cavity + No Sarking + Frame + No Insulation + Plasterboard	0.72/0.89	0.74/0.91
SS-1-70	Panel + Cavity + SS Sarking + Frame + No Insulation + Plasterboard	1.33/1.50	1.46/1.63
NS-2-70	Panel + Cavity + No Sarking + Frame + R2.0 Insulation + Plasterboard	2.63/2.80	2.84/3.01
SS-2-70	Panel + Cavity + SS Sarking + Frame + R2.0 Insulation + Plasterboard	2.63/2.80	2.84/3.01

ONE AAC External Walls on 90mm (nom) Stud Frames

ONE AAC SYSTEM	System details – 90mm Frames The following Systems are all based on 50mm/75mm ONE AAC Panel, 20-40mm Cavity, 90mm Frame Thickness, and 10mm Plasterboard internal linings	Total R Value m ² K/W	
		Summer 50mm/75mm	Winter 50mm/75mm
NS-1-90	Panel + Cavity + No Sarking + Frame + No Insulation + Plasterboard	0.72/0.89	0.74/0.91
SS-1-90	Panel + Cavity + SS Sarking + Frame + No Insulation + Plasterboard	1.34/1.51	1.50/1.67
NS-2-90	Panel + Cavity + No Sarking + Frame + R2.0 Insulation + Plasterboard	2.63/2.80(min)	2.84/3.01(min)
NS-3-90	Panel + Cavity + No Sarking + Frame + R2.5 Insulation + Plasterboard	3.11/3.28(min)	3.24/3.41(min)
SS-2-90	Panel + Cavity + No Sarking + Frame + R2.5 Insulation + Plasterboard	3.11/3.28(min)	3.24/3.41(min)
DS-1-90	Panel + 40mm Cavity + DS Sarking + Frame + R2.5 Insulation + Plasterboard	3.49/3.66	3.83/4.00
FS-1-90	Panel + Cavity + FS Sarking + Frame + R2.0 Insulation + Plasterboard	5.00/5.17	5.20/5.37

ONE AAC Flooring Systems achieve various FRLs as per the following extracts from the Technical Literature:

ONE AAC Floor System – Fire Performance for Fire from Above

FIRE RATING PERFORMANCE - FIRE FROM ABOVE -TABLE 'A'

RATING - Fire from Above (Minutes)	Maximum Joist Spacing (mm)	ONE AAC PANEL Material Above Joists	Fire Rated Plasterboard Material Below Joists
120	600	75mm Panel	Nil

Typical arrangement of ONE AAC Floor system

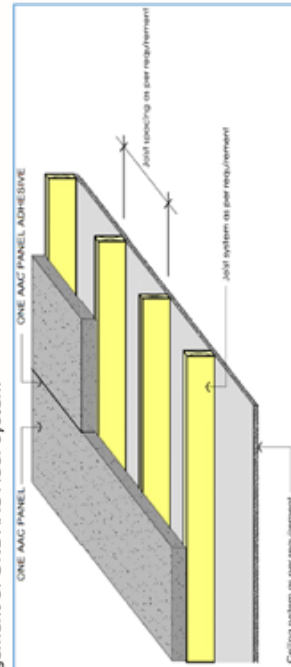

ONE AAC Floor System with Fire Resistant Ceiling Systems – Fire Performance for Fire from Below

FIRE RATING PERFORMANCE - FIRE FROM BELOW - FLOOR / CEILING SYSTEM -TABLE 'B'

RATING - Fire From Below (FRL)	Maximum Joist Spacing (mm)	ONE AAC PANEL Material Above Joists	Fire Rated Plasterboard Material Below Joists
120/120/120	600	75mm Panel	3 layers of 16mm FR PB
90/90/90	600	75mm Panel	2 Layers of 16mm FR PB or 3 layers of 13mm FR PB
60/60/60	600	75mm Panel	2 Layers of 13mm FR PB
30/30/30	450	75mm Panel	1 Layer of 13mm FR PB or 1 layer of 16mm FR PB

KEY:

FRPB Fire Rated Plasterboard

Joists Timber or Steel Joists as per Engineer's requirements



Certificate of Conformity

For system component details & specifications refer to the Product Technical Literature listed as items 1, 2, 3, 4 & 5 in Appendix B2:

- ONE AAC PANEL External Wall System Design and Installation Manual, May 2025.
- ONE AAC PANEL Floor System Design and Installation Manual, May 2025.
- ONE AAC PANEL Party Wall System Design and Installation Manual, May 2025.
- ONE AAC PANEL Dual Boundary Wall System Design and Installation Manual, May 2025.
- ONE AAC PANEL Dual Boundary Wall Construction Guide (DWG & Photos), September 2019.

A4 Manufacturer and manufacturing plant(s)

ONE AAC PANEL
 485 Campbelltown Rd
 Denham Court NSW 2565
 Ph: 1300 010 222
www.oneaac.com.au

A5 Installation requirements

For external walls using ONE AAC panels in Horizontal orientation, refer to the following span table (From ONE AAC PANEL External Wall System Design and Installation Manual, May 2025):

ONE AAC External Walls - Horizontal Panels Spanning and Fixing Guide (50mm & 75mm panels)

TABLE	Max Horizontal Spacing		Max Panel Screw Spacing Vertically	
	For Battens and Panel Screws	Typical Zone	Corner Zone	Typical Zone
N2, N3, C3	600	900	500 (2 screws/600mm)	500 (2 screws/600mm)
P4, C2	600	600	250 (3 screws/600mm)	500 (2 screws/600mm)
N5, C3	450	450	250 (3 screws/600mm)	250 (3 screws/600mm)

Alternately refer to AS 5146.3:2018 – Tables 3.3 A, B, C, D, E, F, G, H & L

Refer to the Product Technical Literature listed as items 1, 2, 3, 4 & 5 in Appendix B2:

- ONE AAC PANEL External Wall System Design and Installation Manual, May 2025.
 - ONE AAC PANEL Floor System Design and Installation Manual, May 2025.
 - ONE AAC PANEL Party Wall System Design and Installation Manual, May 2025.
 - ONE AAC PANEL Dual Boundary Wall System Design and Installation Manual, May 2025.
 - ONE AAC PANEL Dual Boundary Wall Construction Guide (DWG & Photos), September 2019.
- Additional construction details not included in the above Technical Literature may be found in AS 5146.3:2018 – Sections 4.4, 5.4 & 6.3.

A6 Other relevant technical data

Refer to the Product Technical Literature listed as items 1, 2, 3, 4 & 5 in Appendix B2:

- ONE AAC PANEL External Wall System Design and Installation Manual, May 2025.
- ONE AAC PANEL Floor System Design and Installation Manual, May 2025.
- ONE AAC PANEL Party Wall System Design and Installation Manual, May 2025.
- ONE AAC PANEL Dual Boundary Wall System Design and Installation Manual, May 2025.
- ONE AAC PANEL Dual Boundary Wall Construction Guide (DWG & Photos), September 2019.

And any referenced documents within the technical literature identified in Appendices A3 & A5.

APPENDIX B – EVALUATION STATEMENTS

B1 Evaluation methods

The following assessment methods have been used to determine compliance with BCA 2022:

Code Clause	Assessment Method(s)	Evidence of suitability	Evidence reference in B2
BCA Volume One B1P1	A2G2 (2) (a) & (c)	A5G3 (1) (e) & (f) – Expert judgement & Other documentary evidence	Items 1, 2, 3, 4, 5, 6, 7, 8, 9, 10, 11, 12, 13, 14, 15, 16, 17, 18, 19, 20, 21, 22, 23, 41 & 42
BCA Volume Two H1P1	A2G2 (2) (a) & (c)	A5G3 (1) (e) & (f) – Expert judgement & Other documentary evidence	Items 1, 2, 3, 4, 5, 6, 7, 8, 9, 10, 11, 12, 13, 14, 15, 16, 17, 18, 19, 20, 21, 22, 23, 41 & 42
BCA Volume One B1P2	A2G2 (2) (a) & (c)	A5G3 (1) (e) & (f) – Expert judgement & Other documentary evidence	Items 1, 2, 3, 4, 5, 6, 7, 8, 9, 10, 11, 12, 13, 14, 15, 16, 17, 18, 19, 20, 21, 22, 23, 41 & 42
BCA Volume One F3P1	A2G2 (2) (a), (c) & (d)	A5G3 (1) (e) & (f) – Expert judgement & Other documentary evidence	Items 1, 4, 40, 41 & 42
BCA Volume Two H2P2	A2G2 (2) (a), (c) & (d)	A5G3 (1) (e) & (f) – Expert judgement & Other documentary evidence	Items 1, 4, 40, 41 & 42
BCA Volume One B1D4 (b)(ii)	A2G3 (2) (a) & (b)	A5G3 (1) (e) & (f) – Expert judgement & Other documentary evidence	Items 1, 2, 3, 4, 5, 6, 7, 8, 9, 10, 11, 12, 13, 14, 15, 16, 17, 18, 19, 20, 21, 41 & 42
BCA Volume Two H1D7 (4)(a)	A2G3 (2) (a) & (b)	A5G3 (1) (e) & (f) – Expert judgement & Other documentary evidence	Items 1, 2, 3, 4, 5, 6, 7, 8, 9, 10, 11, 12, 13, 14, 15, 16, 17, 18, 19, 20, 21, 41 & 42
BCA Volume One C2D2	A2G3 (2) (a) & (b)	A5G3 (1) (d) & (e) – Test report & Expert judgement	Items 24, 25, 26, 27, 28, 29, 30, 31, 32, 33, 34, 35, 36, 37, 38 & 39
BCA Volume One Specification 1	A2G3 (2) (a) & (b)	A5G3 (1) (d) & (e) – Test report & Expert judgement	Items 24, 25, 26, 27, 28, 29, 30, 31, 32, 33, 34, 35, 36, 37, 38 & 39
BCA Volume One Specification 5	A2G3 (2) (a) & (b)	A5G3 (1) (d) & (e) – Test report & Expert judgement	Items 24, 25, 26, 27, 28, 29, 30, 31, 32, 33, 34, 35, 36, 37, 38 & 39
BCA Volume Two H3D3	A2G3 (2) (a) & (b)	A5G3 (1) (d) & (e) – Test report & Expert judgement	Items 24, 25, 26, 27, 28, 29, 30, 31, 32, 33, 34, 35, 36, 37, 38 & 39
BCA Volume Two Specification 1	A2G3 (2) (a) & (b)	A5G3 (1) (d) & (e) – Test report & Expert judgement	Items 24, 25, 26, 27, 28, 29, 30, 31, 32, 33, 34, 35, 36, 37, 38 & 39
Housing Provisions 9.2.3	A2G3 (2) (a) & (b)	A5G3 (1) (d) & (e) – Test report & Expert judgement	Items 24, 25, 26, 27, 28, 29, 30, 31, 32, 33, 34, 35, 36, 37, 38 & 39
BCA Volume One C2D10	A2G3 (2) (a)	A5.2 (1) (d) – Test report	Items 24, 25, 26, 27, 28, 29, 30, 31, 32, 33, 34, 35, 36, 37, 38 & 39
Housing Provisions 9.3.1	A2G3 (2) (a) & (b)	A5G3 (1) (d) & (e) – Test report & Expert judgement	Items 24, 25, 26, 27, 28, 29, 30, 31, 32, 33, 34, 35, 36, 37, 38 & 39
Housing Provisions 9.3.4	A2G3 (2) (a) & (b)	A5G3 (1) (d) & (e) – Test report & Expert judgement	Items 24, 25, 26, 27, 28, 29, 30, 31, 32, 33, 34, 35, 36, 37, 38 & 39
Housing Provisions 9.4.1	A2G3 (2) (a) & (b)	A5G3 (1) (d) & (e) – Test report & Expert judgement	Items 24, 25, 26, 27, 28, 29, 30, 31, 32, 33, 34, 35, 36, 37, 38 & 39
BCA Volume One F7D3	A2G3 (2) (a) & (b)	A5G3 (1) (d) & (e) – Test report & Expert judgement	Items 1, 2, 3, 4, 5, 6, 7, 43, 44, 45, 46, 47, 48, 49, 50, 51, 52 & 53
BCA Volume One F7D4	A2G3 (2) (a) & (b)	A5G3 (1) (d) & (e) – Test report & Expert judgement	Items 1, 2, 3, 4, 5, 6, 7, 43, 44, 45, 46, 47, 48, 49, 50, 51, 52 & 53
BCA Volume One F7D5	A2G3 (2) (a) & (b)	A5G3 (1) (d) & (e) – Test report & Expert judgement	Items 1, 2, 3, 4, 5, 6, 7, 43, 44, 45, 46, 47, 48, 49, 50, 51, 52 & 53
BCA Volume One F7D6	A2G3 (2) (a) & (b)	A5G3 (1) (d) & (e) – Test report & Expert judgement	Items 1, 2, 3, 4, 5, 6, 7, 43, 44, 45, 46, 47, 48, 49, 50, 51, 52 & 53
Housing Provisions 10.7.1	A2G3 (2) (a) & (b)	A5G3 (1) (d) & (e) – Test report & Expert judgement	Items 1, 2, 3, 4, 5, 6, 7, 43, 44, 45, 46, 47, 48, 49, 50, 51, 52 & 53
Housing Provisions 10.7.2	A2G3 (2) (a) & (b)	A5G3 (1) (d) & (e) – Test report & Expert judgement	Items 1, 2, 3, 4, 5, 6, 7, 43, 44, 45, 46, 47, 48, 49, 50, 51, 52 & 53
Housing Provisions 10.7.3	A2G3 (2) (a) & (b)	A5G3 (1) (d) & (e) – Test report & Expert judgement	Items 1, 2, 3, 4, 5, 6, 7, 43, 44, 45, 46, 47, 48, 49, 50, 51, 52 & 53
BCA Volume One F8D3	A2G3 (2) (a) & (b)	A5G3 (1) (f) – Other documentary evidence	Item 1
BCA Volume Two H4D9	A2G3 (2) (a) & (b)	A5G3 (1) (f) – Other documentary evidence	Item 1
BCA Volume One G5D3	A2G3 (2) (a) & (b)	A5G3 (1) (d) & (e) – Test report & Expert judgement	Items 24, 25, 26, 27, 28, 30 & 31
BCA Volume One G5D4	A2G3 (2) (a) & (b)	A5G3 (1) (d) & (e) – Test report & Expert judgement	Items 24, 25, 26, 27, 28, 30 & 31
BCA Volume Two H7D4 (2)	A2G3 (2) (a) & (b)	A5G3 (1) (d) & (e) – Test report & Expert judgement	Items 24, 25, 26, 27, 28, 30 & 31
BCA Volume One J3D8	A2G3 (2) (a) & (b)	A5G3 (1) (e) – Expert judgement	Items 1, 2, 3, 4, 5, 6, 7, 54, 55, 56, 57, 58, 59, 60, 61 & 62

Code Clause	Assessment Method(s)	Evidence of suitability	Evidence reference in B2
BCA Volume One J4D6	A2G3 (2) (a) & (b)	A5G3 (1) (e) – Expert judgement	Items 1, 2, 3, 4, 5, 6, 7, 54, 55, 56, 57, 58, 59, 60, 61 & 62
Housing Provisions 13.2.5	A2G3 (2) (a) & (b)	A5G3 (1) (e) – Expert judgement	Items 1, 2, 3, 4, 5, 6, 7, 54, 55, 56, 57, 58, 59, 60, 61 & 62
BCA Volume One NT B1D4 (b)(ii)	A2G3 (2) (a) & (b)	A5G3 (1) (e) & (f) – Expert judgement & Other documentary evidence	Items 1, 2, 3, 4, 5, 6, 7, 8, 9, 10, 11, 12, 13, 14, 15, 16, 17, 18, 19, 20, 21, 41 & 42
BCA Volume One QLD B1D4 (b)(ii)	A2G3 (2) (a) & (b)	A5G3 (1) (e) & (f) – Expert judgement & Other documentary evidence	Items 1, 2, 3, 4, 5, 6, 7, 8, 9, 10, 11, 12, 13, 14, 15, 16, 17, 18, 19, 20, 21, 41 & 42
BCA Volume One WA B1D4 (b)(ii)	A2G3 (2) (a) & (b)	A5G3 (1) (e) & (f) – Expert judgement & Other documentary evidence	Items 1, 2, 3, 4, 5, 6, 7, 8, 9, 10, 11, 12, 13, 14, 15, 16, 17, 18, 19, 20, 21, 41 & 42
BCA Volume Two WA H1D7 (4)(a)	A2G3 (2) (a) & (b)	A5G3 (1) (e) & (f) – Expert judgement & Other documentary evidence	Items 1, 2, 3, 4, 5, 6, 7, 8, 9, 10, 11, 12, 13, 14, 15, 16, 17, 18, 19, 20, 21, 41 & 42
Housing Provisions NSW 9.4.1	A2G3 (2) (a) & (b)	A5G3 (1) (d) & (e) – Test report & Expert judgement	Items 24, 25, 26, 27, 28, 29, 30, 31, 32, 33, 34, 35, 36, 37, 38 & 39
Housing Provisions NSW 9.4.3	A2G3 (2) (a) & (b)	A5G3 (1) (d) & (e) – Test report & Expert judgement	Items 24, 25, 26, 27, 28, 29, 30, 31, 32, 33, 34, 35, 36, 37, 38 & 39
BCA Volume One NT F7	A2G3 (2) (a) & (b)	A5G3 (1) (d) & (e) – Test report & Expert judgement	Items 1, 2, 3, 4, 5, 6, 7, 43, 44, 45, 46, 47, 48, 49, 50, 51, 52 & 53
Housing Provisions NT 10.7	A2G3 (2) (a) & (b)	A5G3 (1) (d) & (e) – Test report & Expert judgement	Items 1, 2, 3, 4, 5, 6, 7, 43, 44, 45, 46, 47, 48, 49, 50, 51, 52 & 53
BCA Volume Two TAS H4D9	A2G3 (2) (a) & (b)	A5G3 (1) (f) – Other documentary evidence	Item 1
BCA Volume One NSW G5D3	A2G3 (2) (a) & (b)	A5G3 (1) (d) & (e) – Test report & Expert judgement	Items 24, 25, 26, 27, 28, 30 & 31
BCA Volume Two NSW H7D4 (2)	A2G3 (2) (a) & (b)	A5G3 (1) (d) & (e) – Test report & Expert judgement	Items 24, 25, 26, 27, 28, 30 & 31
BCA Volume One NSW G5D4	A2G3 (2) (a) & (b)	A5G3 (1) (d) & (e) – Test report & Expert judgement	Items 24, 25, 26, 27, 28, 30 & 31
BCA Volume One VIC G5D4	A2G3 (2) (a) & (b)	A5G3 (1) (d) & (e) – Test report & Expert judgement	Items 24, 25, 26, 27, 28, 30 & 31
BCA Volume One NSW J3D8	A2G3 (2) (a) & (b)	A5G3 (1) (e) – Expert judgement	Items 1, 2, 3, 4, 5, 6, 7, 54, 55, 56, 57, 58, 59, 60, 61 & 62
BCA Volume One NSW J4D6	A2G3 (2) (a) & (b)	A5G3 (1) (e) – Expert judgement	Items 1, 2, 3, 4, 5, 6, 7, 54, 55, 56, 57, 58, 59, 60, 61 & 62
BCA Volume One NSW Section J	A2G3 (2) (a) & (b)	A5G3 (1) (e) – Expert judgement	Items 1, 2, 3, 4, 5, 6, 7, 54, 55, 56, 57, 58, 59, 60, 61 & 62
Housing Provisions NSW 13.2.5	A2G3 (2) (a) & (b)	A5G3 (1) (e) – Expert judgement	Items 1, 2, 3, 4, 5, 6, 7, 54, 55, 56, 57, 58, 59, 60, 61 & 62
BCA Volume Two NSW Part H6	A2G3 (2) (a) & (b)	A5G3 (1) (e) – Expert judgement	Items 1, 2, 3, 4, 5, 6, 7, 54, 55, 56, 57, 58, 59, 60, 61 & 62
BCA Volume Two NT Part H6	A2G3 (2) (a) & (b)	A5G3 (1) (e) – Expert judgement	Items 1, 2, 3, 4, 5, 6, 7, 54, 55, 56, 57, 58, 59, 60, 61 & 62
Housing Provisions NT 13.2.5	A2G3 (2) (a) & (b)	A5G3 (1) (e) – Expert judgement	Items 1, 2, 3, 4, 5, 6, 7, 54, 55, 56, 57, 58, 59, 60, 61 & 62
BCA Volume One TAS Part J3	A2G3 (2) (a) & (b)	A5G3 (1) (e) – Expert judgement	Items 1, 2, 3, 4, 5, 6, 7, 54, 55, 56, 57, 58, 59, 60, 61 & 62
BCA Volume Two TAS Part H6	A2G3 (2) (a) & (b)	A5G3 (1) (e) – Expert judgement	Items 1, 2, 3, 4, 5, 6, 7, 54, 55, 56, 57, 58, 59, 60, 61 & 62
Housing Provisions TAS 13.2	A2G3 (2) (a) & (b)	A5G3 (1) (e) – Expert judgement	Items 1, 2, 3, 4, 5, 6, 7, 54, 55, 56, 57, 58, 59, 60, 61 & 62



Certificate of Conformity

APPENDIX B cont'd B2 Reports

The following reports have been used as evidence to determine compliance with BCA 2022

Ref	Author	Reference	Date	Description	NATA Registration
1	ONE AAC PANEL	External Wall Design & Installation Manual	May 2025	Client published design & installation manual	-
2	ONE AAC PANEL	Flooring Design & Installation Manual	May 2025	Client published design & installation manual	-
3	ONE AAC PANEL	Party Wall Design & Installation Manual	May 2025	Client published design & installation manual	-
4	ONE AAC PANEL	Dual Zero Boundary Wall Design & Installation Manual	May 2025	Client published design & installation manual	-
5	ONE AAC PANEL	Dual Zero Boundary Wall Construction Details	Sep 2019	Client published drawings and details	-
6*	Enertrén	ONE-007 V.4	10 Feb 2022	Compliance review of ONE AAC systems against NCC	-
7*	Enertrén	ONE-013 V.3	10 Feb 2022	Compliance review of ONE AAC systems against NCC	-
8*	ONE AAC PANEL	Batch Testing 50mm Panel	15 Mar 2018	Quality control structural test document	-
9*	Enertrén	AS4055-2006 Connection Design	9 Apr 2013	Structural calculation report	-
10*	Enertrén	ONE-011 V.1	10 Feb 2022	Structural Design Certification	-
11*	Enertrén	ONE-012 V.3	10 Feb 2022	Structural Design Certification	-
12*	BEMAC Laboratories	10953 – 50mm x 2.7m mesh panel	6 Mar 2017	Structural test report	1393
13*	BEMAC Laboratories	10953 – 50mm x 3.0m mesh panel	4 May 2017	Structural test report	1393
14*	Pace Structural	PS 18013 – 50mm AAC Zero Boundary Walls	22 Jan 2025	Structural Design Certification	-
15*	Pace Structural	PS 18022 – 50mm AAC Party Walls	22 Jan 2025	Structural Design Certification	-
16*	Pace Structural	PS 20116 – 75mm AAC Flooring	23 Jan 2025	Structural Design Certification	-
17*	Pace Structural	PS 20123 – 75mm AAC External Walls	23 Jan 2025	Structural Design Certification	-
18*	Pace Structural	PS 18153 – 75mm AAC Vert External Walls	23 Jan 2025	Structural Design Certification	-
19*	Pace Structural	PS 18158 – 75mm AAC Party Walls	20 Mar 2025	Structural Design Certification	-
20*	Pace Structural	PS 19167 – 75mm AAC Flooring	11 Apr 2021	Structural Design Certification	-
21*	Pace Structural	PS 20145 – 50mm AAC External Walls	22 Jan 2025	Structural Design Certification	-
22*	Mahaffey Associates	BAS/25/L01/9830	26 Feb 2025	Durability assessment report	-
23*	The Coatings Consultancy	TCC18025-B-20231018	18 Oct 2023	Durability assessment report	-
24*	CSIRO	FNCL2427A	2 Sep 2019	Fire Test Report	165
25*	CSIRO	FNCL2490	22 Nov 2019	Fire Test Report	165
26*	CSIRO	FCO-2532 Rev G	20 Aug 2024	Fire Assessment Report	165
27*	CSIRO	FCO-3003 Rev F	3 Dec 2024	Fire Assessment Report	165
28*	CSIRO	FCO-3241 Rev D	3 Dec 2024	Fire Assessment Report	165
29*	CSIRO	FCO-3255 Rev G	1 Sep 2021	Fire Assessment Report	165
30*	CSIRO	FCO-3451 Rev D	30 Aug 2024	Fire Assessment Report	165
31*	WarringtonFire Australia	FAS200114 – 24917 R3.1	26 May 2022	Fire Assessment Report	3277
32*	WarringtonFire Australia	FAS190160 – 45771 R21.0	23 Feb 2023	Fire Assessment Report	3277
33*	WarringtonFire Australia	FAS200249 – 27915 R1R 28.3	25 Sep 2024	Fire Assessment Report	3277

Ref	Author	Reference	Date	Description	NATA Registration
34*	BRANZ	FC12946-02-05	23 Dec 2024	Fire Assessment Report	IANZ 37
35*	BRANZ	FC12969-02-02	23 Dec 2024	Fire Assessment Report	IANZ 37
36*	SGA Fire	115620-FAR2-r2	1 Mar 2023	Fire Assessment Report	-
37*	WarringtonFire Australia	FAS190160 RIR21.0	27 Feb 2023	Fire Assessment Report	3277
38*	Jensen Hughes	115620-FAR10-r2	27 Apr 2023	Fire Assessment Report	-
39*	Jensen Hughes	FAS200088 - 26162 RIR3.7	27 Nov 2024	Fire Assessment Report	3277
40*	Energren	ONE-009 V.1	5 Sep 2019	Weatherproofing Assessment Report	-
41*	AECOM	2021.04.08_FV1.1_HEB	8 Apr 2021	Weatherproofing Assessment Report	-
42*	Xavier Knight	220912 Rev 06	8 Aug 2024	Weatherproofing Assessment Report	-
43*	Koikas Acoustics	2679C20150827NK v1	3 Jun 2015	Acoustic Test Report	-
44*	Koikas Acoustics	2878C20151112MFC v1	12 Nov 2015	Acoustic Test Report	-
45*	Koikas Acoustics	2878C20181031NK v2	9 Nov 2016	Acoustic Assessment Report	-
46*	Renzo Tonin & Assoc	T6553-01F02 (rev 0)	6 Feb 2014	Acoustic Assessment Report	-
47*	AcousticLogic	201307861.1/0209A/R0/GW	2 Sep 2013	Acoustic Assessment Report	-
48*	AcousticLogic	20140366.35/0202A/R6/GW	2 Feb 2018	Acoustic Assessment Report	-
49*	AcousticLogic	20171728.13/0507A/R6/GW	1 May 2019	Acoustic Assessment Report	-
50*	AcousticLogic	20171728.18/1302A/R1/GW	13 Feb 2020	Acoustic Assessment Report	-
51*	AcousticLogic	20210103.13/1105A/R0/TB	11 May 2023	Acoustic Assessment Report	-
52*	AcousticLogic	2010861.19/0508A/R3/GW	5 Aug 2016	Acoustic Assessment Report	-
53*	PKA Acoustic Consulting	PKA-A071	18 Apr 2023	Acoustic Assessment Report	-
54*	Energren	75mm AAC Panel R-Value	27 Nov 2015	Thermal Assessment Report	-
55*	Energren	ONE-AAC Cladding Wall 75mm R Values	9 Apr 2013	Thermal Calculation Report	-
56*	CSR Insulation	NR-12140	10 Oct 2012	Thermal Test Report	993
57*	James M Fricker	107w2509p-w26111p	15 Apr 2024	Thermal Calculation Report	-
58*	James M Fricker	107w25011n-w2520	29 Apr 2024	Thermal Calculation Report	-
59*	James M Fricker	107w25011n-w2520	29 Apr 2024	Thermal Calculation Report	-
60*	James M Fricker	107w26011n-w2720	8 Mar 2024	Thermal Calculation Report	-
61*	James M Fricker	107.23i - 107.29ii	1 Sep 2020	Thermal Calculation Report (timber frame)	-
62*	James M Fricker	107.23i - 107.29ii	1 Sep 2020	Thermal Calculation Report (steel frame)	-

* The Certificate Holder has chosen not to make the above identified evidence of compliance publicly available, due to the documents being considered commercial in confidence.

PHOTO GALLERY

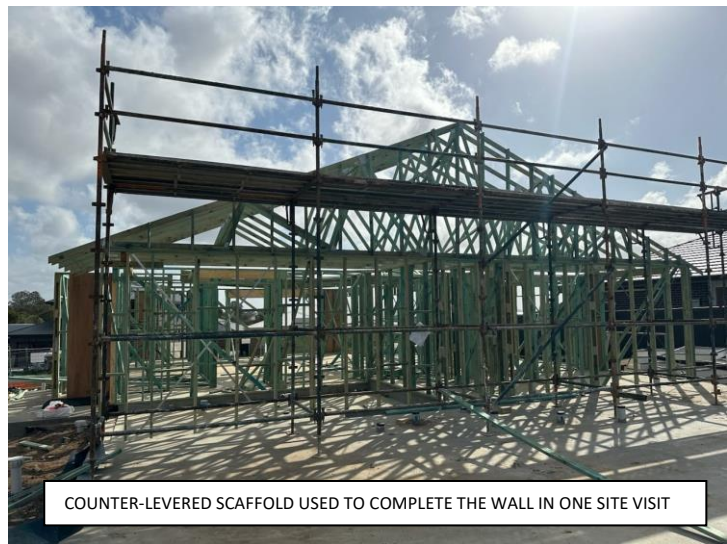

COUNTER-LEVERED SCAFFOLD USED TO COMPLETE THE WALL IN ONE SITE VISIT



ONE AAC PARTY WALL COMPLETED AND READY FOR FRAMEWORK TO BE INSTALLED ON THIS SIDE OF THE PARTY WALL.

PLEASE NOTE: ALUMINIUM BRACKETS TO BE INSTALLED ON THIS SIDE ONCE FRAME IS INSTALLED.



Notes:

ONE AAC PANEL

Head Office:

485 Campbelltown Rd

Denham Court NSW 2565

Tel: **1300 010 222 (AAC) or 02 9756 5029**

Mobile: 0439 28 30 30

Email: info@oneaac.com.au

Web: www.oneaac.com.au